

**BUCKS COUNTY WATER & SEWER AUTHORITY**

***STANDARD WATER & SEWER SPECIFICATIONS***



**BUCKS COUNTY WATER & SEWER AUTHORITY**

**1275 ALMSHOUSE ROAD**

**WARRINGTON, PA 18976**

**JANUARY, 2020**

**UPDATED MARCH 2026**

**BUCKS COUNTY WATER & SEWER AUTHORITY**  
***STANDARD WATER & SEWER SPECIFICATIONS***

**TABLE OF CONTENTS**

**DIVISION 1 - GENERAL REQUIREMENTS**

01010	General Requirements
01015	Design Standards and Special Requirements
01420	Preconstruction Audio-Video Documentation

**DIVISION 2 – SITE WORK**

02110	Clearing and Grubbing of Easements
02170	Stream Crossings
02220	Excavation, Backfill and Compaction
02229	Rock Removal
02250	Environmental Protection
02300	Boring and Jacking Operations
02519	Tracer Wire
02575	Restoration of Paved Surfaces
02605	Manholes and Vaults
02610	Utility Pipe and Fittings
02650	Water and Sanitary Sewer System Testing
02660	Water Distribution Specialties
02735	Low Pressure Sewer Systems
02770	Sanitary Sewage Specialties
02832	Chain Link Fence and Gates
02905	Landscaping

**DIVISION 3 - CONCRETE**

03302	Concrete Work for Utilities
-------	-----------------------------

**DIVISION 9 - FINISHES**

09900	Painting
-------	----------

**DIVISION 11 - EQUIPMENT**

11306	Sewage Pumping Station
-------	------------------------

**DIVISION 15 - MECHANICAL**

15260	Piping Insulation and Heat Tracing
-------	------------------------------------

**DIVISION 16 - ELECTRICAL**

16622	Standby Electric Generating System
-------	------------------------------------

**BUCKS COUNTY WATER & SEWER AUTHORITY**  
***STANDARD WATER & SEWER SPECIFICATIONS***

**TABLE OF CONTENTS**  
**(Continued)**

**APPENDICES**

- A List of Bucks County Water and Sewer Authority - Owned Water and Sanitary Sewer Systems
- B Maintenance Bond
- C BCWSA Sanitary Sewer System Review/Dedication Process
- D BCWSA Water System Review/Dedication Process

**BUCKS COUNTY WATER AND SEWER AUTHORITY**  
**STANDARD DETAILS**  
**TABLE OF CONTENTS**

***SANITARY SEWER DETAILS***

<b>DETAIL NO.</b>	<b>DESCRIPTION</b>
S-1	TYPE "A" STANDARD MANHOLE
S-2	TYPE "B" SHALLOW MANHOLE
S-3	DOGHOUSE MANHOLE CONSTRUCTION
S-4	DROP MANHOLE CONNECTION
S-5	STANDARD MANHOLE FRAME AND COVER
S-6	WATERTIGHT MANHOLE FRAME AND COVER
S-7	ALUMINUM MANHOLE STEP
S-8	POLYPROPYLENE MANHOLE STEP
S-9	LATERAL CONNECTION SHALLOW SEWER
S-10	LATERAL CONNECTION DEEP SEWER
S-11	SERVICE CONNECTION FOR SUBLATERAL FACILITIES
S-12	CLEANOUT PROTECTION SLEEVE (FOR USE IN OR NEAR PAVED AREAS)
S-13	SEWER SADDLE
S-14	REPLACEMENT OF EXISTING SEWER
S-15	TYPICAL PUMP STATION LAYOUT SKETCH
S-16	TYPICAL PUMP STATION PLAN VIEW AND NOTES
S-17	TYPICAL PUMP STATION SECTION VIEW
S-18	TYPICAL SEWAGE GRINDER CHANNEL FRAME AND RAIL SYSTEM
S-19	FORCE MAIN AIR RELEASE CHAMBER
S-20	FORCE MAIN CLEANOUT CHAMBER
S-21	TYPICAL GRINDER PUMP STATION INSTALLATION
S-22	LOW PRESSURE SEWER LATERAL CONNECTION W/CHECK VALVE
S-23	LOW PRESSURE SEWER CONNECTION (RESIDENTIAL FORCE MAIN TO GRAVITY LATERAL CONNECTION)
S-24	LOW PRESSURE SEWER TERMINAL CLEANOUT
S-25	LOW PRESSURE SEWER IN-LINE CLEANOUT
S-26	LOW PRESSURE SEWER DROP CONNECTION IN EXISTING MANHOLE
S-27	Quick Connect

**BUCKS COUNTY WATER AND SEWER AUTHORITY**  
**STANDARD DETAILS**  
**TABLE OF CONTENTS**

***WATER DETAILS***

<b>DETAIL NO.</b>	<b>DESCRIPTION</b>
W-1	SERVICE CONNECTION
W-2	TYPICAL CURB STOP & VALVE BOX
W-3	FIRE HYDRANT CONNECTION
W-4	TYPICAL GATE VALVE WITH VALVE BOX
W-5	AIR RELEASE VALVE
W-6	AIR RELEASE VALVE MANHOLE
W-7	RESEIDENTIAL METER INSTALLATION
W-8	BACKFLOW PREVENTER FOR PRIVATE FIRE SERVICE
W-9	BLOW-OFF ASSEMBLY
W-10	VALVE RODDED AT DEAD END
W-11	KORNERHORN DETAIL

**BUCKS COUNTY WATER AND SEWER AUTHORITY**  
**STANDARD DETAILS**  
**TABLE OF CONTENTS**

***MISCELLANEOUS DETAILS***

<b>DETAIL NO.</b>	<b>DESCRIPTION</b>
M-1	STANDARD PIPE BEDDING
M-2	CONCRETE ENCASEMENT
M-3	HORIZONTAL THRUST BLOCK
M-4	VERTICAL DOWNWARD THRUST BLOCK
M-5	VERTICAL UPWARD THRUST BLOCK
M-6	HORIZONTAL & VERTICAL DOWNWARD THRUST BLOCK BEARING SURFACE AREAS
M-7	JACKING CONDUIT
M-8	PIPELINE STREAM CROSSING – ALTERNATIVE “A”
M-9	PIPELINE STREAM CROSSING – ALTERNATIVE "B"
M-10	STRAPPING RESTRAINT HARNESS DETAIL

**BUCKS COUNTY WATER AND SEWER AUTHORITY**  
**STANDARD DETAILS**  
**TABLE OF CONTENTS**

***TRENCH RESTORATION DETAILS***

<b>DETAIL NO.</b>	<b>DESCRIPTION</b>
TR-1	TRENCH RESTORATION FOR UNIMPROVED SHOULDER OF STATE HIGHWAY, TOWNSHIP ROAD, OR IN EASEMENT
TR-2	TRENCH RESTORATION FOR UNIMPROVED SHOULDER OF STATE HIGHWAY OR TOWNSHIP ROAD (<3' FROM EDGE OF PAVEMENT)
TR-3	TEMPORARY PAVEMENT FOR TOWNSHIP ROAD AND STATE HIGHWAY
TR-4	TRENCH RESTORATION FOR STABILIZED SHOULDER OF STATE HIGHWAY OR TOWNSHIP ROAD
TR-5	PERMANENT PAVEMENT, TRENCH RESTORATION AND BACKFILL FOR TOWNSHIP ROADS
TR-6	PERMANENT PAVEMENT, TRENCH RESTORATION AND BACKFILL FOR STATE HIGHWAYS
TR-7	STABILIZED ACCESS BED DETAIL

## **SECTION 01010 GENERAL REQUIREMENTS**

### **PART 1 - GENERAL**

#### **01010.1.01 DESCRIPTION**

- A. Work to be covered by these Specifications consists of all labor, tools, equipment, materials, machinery, apparatus, and other facilities necessary and proper to construct, install, equip, adjust, and to put into satisfactory operation any public water extensions, services, and related water facilities, and any sanitary sewer main extensions, sanitary sewer force mains, sewage pumping stations, and related sewer facilities, including the associated appurtenances and restoration work. Any labor, materials, equipment or apparatus not specifically mentioned herein, or shown on the Detail Drawings, which may be found necessary to complete or perfect any portion of the work in a substantial manner and in compliance with the requirements stated or implied by these Specifications and Standard Details; shall be provided by the Developer.
- B. The Specifications in this document are written with the intention of, in whole or in part, to be included in the work completed for the DEVELOPER by the CONTRACTOR. AUTHORITY will not accept the public water facilities or sanitary sewer facilities provided by a DEVELOPER unless and until they conform to the requirements of the applicable portions of these Specifications. These Specifications are not intended to provide a complete description of the requirements for private water or sewer lines and facilities located outside of the public right-of-way or easement, or within the interior of the structure receiving public water or sewer service. The Uniform Construction Code, as amended by the governing body where the facilities are located, shall apply in those locations unless specifically indicated otherwise in this Standard Specification or on the Standard Details.
- C. The Drawings and Specifications are intended to cover a complete project with respect to public water and sanitary sewer facilities, and it shall be thoroughly understood that failure to mention specifically any work that would naturally be required to complete the project shall not relieve DEVELOPER of the responsibility to perform such work.
- D. The Standard Details at the end of this document represent the standards of construction of the AUTHORITY. Where reference is made herein to "Detail Drawings" or "Standard Details", it shall be understood to mean these drawings. They are to be utilized by DEVELOPER and/or DEVELOPER's Engineer in preparing plans for public water extensions and services, sanitary sewer extensions and laterals, water and sanitary sewage pumping stations, sewage force mains, and all appurtenant facilities.
- E. Refer to Appendix A for a list of water and sanitary sewer systems owned by the Bucks County Water and Sewer Authority for which these Drawings and Specifications are to apply.
- F. The AUTHORITY's review and dedication procedures are outlined in Appendix C and D.

## 01010.1.02 DEFINITIONS

Wherever in these Specifications the following words, terms, and expressions, or pronouns in place of them are used, the intent and meaning shall be interpreted as follows:

AUTHORITY: Bucks County Water & Sewer Authority, acting directly or through any agent, officer, or employee duly authorized to act for the said part in the execution of the legal functions of the AUTHORITY.

ENGINEER: The AUTHORITY Engineer, duly employed by Bucks County Water & Sewer Authority as consultant and authorized to inspect the results of the performance of the work by CONTRACTOR, acting directly or through properly authorized agents, engineers, assistants, inspectors, or other representatives acting severally within the scope of the particular duties entrusted to them. The word "ENGINEER" shall include the officers, agents, or employees of ENGINEER.

DEVELOPER: The corporation, partnership, or individual intending to develop for residential or other purposes, a certain tract of land situated within the sewer and/or water franchise areas of the AUTHORITY, acting directly or through any authorized lawful agents, legal representatives or employees appointed to act for said party in the execution of the work. "DEVELOPER" shall also be interpreted to mean DEVELOPER's Contractor performing the actual installation of sanitary or water facility.

DEVELOPER's Contractor: Acting directly or through authorized lawful agents, legal representatives, superintendents, or employees, appointed to act for said party in the performance of the work under contract. In the context of these Specifications, the term "CONTRACTOR" shall also be interpreted as the "DEVELOPER" in certain instances where specific responsibilities are not defined or can be performed by either party.

Project: All the necessary performance, services, and materials required for the satisfactory completion of the work under the Agreement and as described in the Specifications and shown on the Drawings.

Specifications: Collectively the Standard Specifications and Details for public water and sanitary sewer facilities and all of the written technical descriptions of materials, equipment, construction systems, standards and workmanship pertaining to the construction of the project which are a part of the Project but not contained herein.

Drawings and Plans: Collectively, all of the drawings which show the character and scope of the work to be performed on the project and which have been prepared by a Professional Engineer and approved by AUTHORITY; and also such supplementary drawings as may be issued from time to time in order to elucidate or clarify said Project Drawings or show details which are not shown thereon.

Resident Project Representative: The authorized representative of ENGINEER who may be assigned to the site of the Work.

Township: The governing body, Township or Borough, acting directly or through any agent, officer or employer authorized to act for Township/Borough in the execution of the legal functions of Township/Borough.

Inspection: The examination of the Work performed by CONTRACTOR to determine its conformity with the Drawings and the Specifications.

Work: The entire completed construction of the public water and/or sanitary sewerage facilities to be dedicated to AUTHORITY as shown on the Drawings and described in the Specifications. The Work includes, and is the result of, performing or furnishing labor and incorporating materials and equipment into the construction and performing or furnishing services and furnishing documents, all as required by the Drawings and the Specifications.

### **01010.1.03 REFERENCED STANDARDS AND SPECIFICATIONS**

All work shall comply with the current issues of the following codes, regulations and requirements, any or all references to earlier dated editions notwithstanding.

1. Pennsylvania Department of Labor and Industry, Regulations for Trenches and Excavations
2. Federal and State Air Pollution Regulations
3. AASHTO - American Association of State Highway and Transportation Officials
4. ACI - American Concrete Institute
5. AISC - American Institute of Steel Construction, Manual of Steel Construction
6. ANSI - American National Standards Institute
7. ASME - American Society of Mechanical Engineers
8. ASTM - American Society of Testing and Materials
9. AWWA - American Water Works Association
10. IPC - International Plumbing Code
11. DEP - Pennsylvania Department of Environmental Protection: Erosion and Sediment Pollution Control Manual and Domestic Wastewater Facilities Manual
12. FS - Federal Specifications
13. ISO - Insurance Services Office
14. NACE - National Association of Corrosion Engineers
15. NEC - National Electric Code
16. NEMA - National Electrical Manufacturer's Association
17. NFPA - National Fire Protection Association
18. OSHA - Occupational Safety and Health Administration
19. PennDOT - Pennsylvania Department of Transportation Publications 213, 408 and 459
20. PTM - Pennsylvania Test Method
21. UCC - Uniform Construction Code

#### **01010.1.04 EASEMENT/PROPERTY DEDICATIONS**

- A. DEVELOPER shall be responsible to acquire all necessary off-site easements and property prior to start of construction. The DEVELOPER shall pay all costs associated with easement and property acquisition.
- B. AUTHORITY may assist in acquiring an off-site easement or property utilizing its right of eminent domain, if such easement of property is deemed in the best interest of the public.
- C. DEVELOPER shall provide dedications of easements and property within the development site at the execution of the Financial Agreement to be recorded by the AUTHORITY. Easements with specific metes and bounds will be required for utilities to be offered for dedication in unpaved areas. A blanket access easement will be sufficient for utilities to be offered for dedication when said utilities are within proposed roadways.
- D. Easement widths and alignments shall be as follows:
  - 1. Public Water Distribution and Transmission mains shall have a minimum width of thirty (30) feet.
  - 2. Sanitary Force Mains, Collection Sewers, and Trunk Sewers shall have a minimum width of thirty (30) feet.
  - 3. Public Water Transmission mains, 16" and larger, shall have a minimum width of forty (40) feet.
  - 4. Sanitary Interceptor Sewers shall have a minimum width of fifty (50) feet.
  - 5. All piping shall be constructed as close as possible to the centerline of the easement provided and no closer than 10-feet to the edge of a 30-foot easement, and no closer than 15-feet to the edge of an easement that is wider than 30-feet.
  - 6. Greater easement widths may be required as directed by the ENGINEER.
- E. Easement plans shall be provided on 8 1/2" x 11" drawings.
- F. All easements shall be fully described with metes and bounds shown on the Plan & Profile sheets and on the Subdivision Plan to be recorded. Where required by the ENGINEER, the sewer/water lines and/or easements shall be extended to the property line.
- G. Any public water or sewage pumping station site, including access, should be provided to AUTHORITY in the form of fee simple ownership. The minimum area of the sewage pump station parcel shall be 0.5 acre, or as required by Local Ordinance, or Land Development Regulations. The necessary site area and configuration shall be acceptable to AUTHORITY.

- H. There shall not be built, installed, constructed, planted or located any temporary or permanent buildings or structures, or any trees, shrubs or other landscaping within AUTHORITY permanent easements, except trees, shrubs and other landscaping which will not grow to more than six (6) feet in height.
- I. Stabilized access bed shall be provided through easements for maintenance equipment where required by OWNER (See Detail TR-7).

#### **01010.1.05 EQUAL OR APPROVED EQUAL**

- A. In the various detailed sections of the Specifications, where any item of material or equipment is specified by proprietary name, trade name, and/or name of one or more manufacturers, without the addition of such expressions as "or equal", it is to be understood that these items are so specified for reasons of standardization or for special requirements of the job. For items so specified, no substitute products will be acceptable.
- B. In the various detailed sections of the Specifications, where any item of equipment is specified by proprietary name, trade name, and/or name of one or more manufacturers, with the additions of such expressions as "or equal", it is to be understood that equal quality equipment or products, of either a manufacturer named or of a manufacturer not named, which meet the detailed requirements of the specifications, are intended and are subject to the acceptance of ENGINEER as to the equality thereof. It is distinctly understood that: (1) ENGINEER is to use own judgment in determining whether or not any item of equipment or product proposed is equal to that specified; (2) the decision of AUTHORITY on all such questions of equality shall be final; and (3) in the event of any adverse decision by ENGINEER, no claim of any sort shall be made or allowed against ENGINEER or AUTHORITY.
- C. If, in normally rare occurrences, it becomes necessary (because of delays in delivery, strikes, discontinuance of the manufacture of items specified or the equal thereof, or any other similar reasons) for DEVELOPER to request the use of any item of equipment or product which is of a different type than the equipment or product specified, or the approved equal thereof, ENGINEER at own discretion, may authorize the use of such different type equipment or product of the same, greater or less cost than that specified.
- D. In such cases as described in Paragraphs B and C above, DEVELOPER shall submit to ENGINEER in writing (1) the request for permission to make a substitution, and (2) a complete description of the proposed item, including dimensions, operational characteristics, changes (if any) that will be required to other related parts of the work, etc.
- E. If any submitted equipment necessitates changing electrical, water, gas, vacuum, air, or other utility services from the sizes, capacities, configurations and locations shown on the Drawings, it shall be DEVELOPER's responsibility to bear the construction cost of all changes. It shall also be DEVELOPER's responsibility to bear the cost of engineering fees to analyze, design, specify, and formulate the construction changes necessitated by the proposed deviations from the specified equipment and/or the Drawings.
- F. The decision of ENGINEER, from time to time, shall be final and conclusive upon DEVELOPER.

#### **01010.1.06 OBSERVANCE OF LAWS**

DEVELOPER at all times shall observe and comply with all Federal and State laws and regulations, and local bylaws, ordinances and regulations in any manner affecting the conduct of the work or applying to employees on the Project, as well as all safety precautions and orders or decrees which have been promulgated or enacted, or which may be promulgated or enacted, by any legal bodies or tribunals having authority or jurisdiction over the work, materials, equipment, or the employees; such observance and compliance shall be solely and without qualification the responsibility of DEVELOPER without reliance on superintendence or direction by AUTHORITY or ENGINEER. The duty of enforcement of all of said laws, ordinances, regulations, orders, or decrees lies with the body or agency promulgating them, not with AUTHORITY or ENGINEER.

#### **01010.1.07 REGULATIONS OF THE DEPARTMENT OF LABOR AND INDUSTRY**

Special attention is drawn to the regulations of the Pennsylvania Department of Labor and Industry relating to wage scales, trenches and excavations, tunnel construction, equipment, materials, labor, safety, sanitation, and other regulations on which DEVELOPER shall be fully informed and with which DEVELOPER shall fully comply. Observance of and compliance with said regulations shall be solely and without qualification the responsibility of DEVELOPER, without reliance on superintendence of or direction by AUTHORITY or ENGINEER. The duty of enforcing such laws and regulations lies with the said Department, not with AUTHORITY or ENGINEER.

#### **01010.1.08 PERMITS AND LICENSES**

- A. DEVELOPER shall be responsible for securing all necessary governmental permits/applications for the Work prior to start of construction and shall give all notices necessary and incident to the proper and lawful prosecution of the work. DEVELOPER shall pay all application fees, charges, and costs associated with the required submissions for permits and approvals. A copy of all permits /approvals shall be provided to AUTHORITY prior to start of construction.
- B. Where public water and/or sanitary sewer facilities are to be constructed within State Highways or Railroad rights-of-way (ROW), the DEVELOPER shall prepare necessary applications in the name of the Bucks County Water & Sewer Authority for permits to construct such facilities and shall pay all charges and fees required. Permit applications should be submitted to the ENGINEER for review. It shall be, however, the responsibility of the DEVELOPER to construct the project in strict conformance with the requirements of the Pennsylvania Department of Transportation or the Railroad.
  1. Within State Highway ROW – DEVELOPER shall include authorization form with submittal to ENGINEER. Following review approval, AUTHORITY will execute form and return to DEVELOPER for submittal through PADOT’s Electronic Permitting System (EPS). ENGINEER shall be included as a member of the Applicant Team.
  2. Within Railroad ROW – Following review approval, the permit application shall be forwarded to the AUTHORITY for review, execution, and forwarding to the Railroad. The DEVELOPER/CONTRACTOR shall be governed by the requirements of the railroad company involved, and shall consult with the officials thereof relative to the installation.

- C. Local Townships require a “Road Opening Permit” be obtained to perform any construction with the rights-of-way of Township streets. The DEVELOPER shall obtain all such Road Opening Permits and shall pay all fees and charges required therefor.
- D. If the Pennsylvania Department of Transportation, Township, Railroad Company, or any regulatory agency requires any of their personnel to be on hand during the construction of the work, payment for such personnel shall be borne by DEVELOPER/CONTRACTOR.
- E. Permits/approvals may include but are not limited to the following:
1. PA Department of Environmental Protection
    - Public Water Supply Permit
    - Planning Module Approval (Act 537)
    - Water Quality Management Permit
    - BDWM-GP-5 (Utility Line Stream Crossing)
  2. PennDOT
    - Highway Occupancy Permit
    - Minimum Use Driveway
    - Detour Plans
  3. County Conservation District
    - Soil Erosion and Sedimentation Control Plan Approval
  4. Local Township
    - Road Opening Permit
    - Blasting Permit
  5. Philadelphia Electric Company
    - Service and Metering Permit
    - Service Agreement
  6. Verizon, Comcast and other communication utilities
- F. CONTRACTOR is responsible for complying with all relevant conditions of any governmental permits or approvals for the Work, including giving all necessary notices.

### **01010.1.09 NOTICE**

The service of any notice by AUTHORITY or ENGINEER to DEVELOPER or CONTRACTOR shall be considered accomplished upon completion of any one of the following procedures:

- A. When delivered, in writing, to the person in charge of the office used by the addressee to conduct business;
- B. When delivered, in writing, to the addressee or any of their authorized agents in person;
- C. When delivered, in writing, to the addressee or any of their agents at the office used by the addressee to conduct business of the Project at or near the Site of the work; or
- D. When deposited in the United States Mail, postpaid, or transmitted by e-mail or fax machine, and addressed to the party intended for such service at their office used for conducting the business of the Project at the Site of the work, or their last known place of business.

### **01010.1.10 ADVERTISING**

No advertising will be permitted on any part of buildings, scaffolding, fences, materials, obstructions, barricades, or work.

### **01010.1.11 DEVELOPER'S INSURANCE REQUIREMENTS**

- A. The DEVELOPER's Contractor is required to maintain Bodily Injury Liability Insurance including Personal Injury and Property Damage Liability in Comprehensive form, to include Operations, Explosion, Collapse and Underground Hazard, Products and Completed Operations Hazard, Contractual and Independent Contractors. These policies shall contain an endorsement adding AUTHORITY and ENGINEER as an additional named insured.
- B. Vehicle insurance shall be maintained on a Comprehensive form to include Owned, Hired, and Non-Owned. These policies shall contain an endorsement adding AUTHORITY as an additional named insured.
- C. CONTRACTOR shall maintain Workmen's Compensation Insurance, including Employer's Liability for all operations as required by law.
- D. The CONTRACTOR shall maintain limits of liability for the above-mentioned insurance in an amount not less than two million dollars (\$2,000,000.00).
- E. At least seven (7) calendar days prior to starting work, the CONTRACTOR shall submit certificates of insurance for all coverages detailed above.
- F. The CONTRACTOR shall require all Subcontractors to maintain all required insurance coverage as required of the CONTRACTOR under the Specifications.

- G. The CONTRACTOR shall indemnify and hold harmless AUTHORITY and ENGINEER of all claims made by employees of either the CONTRACTOR or Subcontractor arising from the execution of work required under this Project.
- H. The CONTRACTOR shall carry Worker's Compensation Insurance, including Employer's Liability, during the life of the Project to insure statutory liability to CONTRACTOR's employees in the State of Pennsylvania. The minimum limits of liability shall be as follows:

**Minimum Limits**

1.	State:	Statutory
2.	Applicable Federal (e.g. Longshoremen's):	Statutory
3.	Employer's Liability:	
	a. Bodily Injury by Accident (each accident):	\$100,000.00
	b. Bodily Injury by Disease (policy limit):	\$500,000.00
	c. Bodily Injury by Disease (each employee):	\$100,000.00

- I. The CONTRACTOR shall carry the Comprehensive Form of Automobile Liability and Property Damage Insurance during the life of the Project covering the risks itemized in the form of "Certificate of Insurance" provided for in the Project. The minimum limits of liability shall be as follows:

**Minimum Limits**

1.	Combined Single Limit (bodily injury and property damage)	\$2,000,000.00 Each Accident
----	--	---------------------------------

- J. The CONTRACTOR shall carry the Comprehensive Form of General Liability and Property Damage Insurance during the life of the Project covering the risks itemized in the form of "Certificate of Insurance" provided for in the Project. The CONTRACTOR's General Umbrella Liability shall include environmental coverage covering contamination of streams, wetlands and other bodies of water and contamination of the ground at or below the surface from the discharge of sewage during bypass pumping or other work by the CONTRACTOR, either accidentally or on purpose. Policies shall be written in the name of the CONTRACTOR, AUTHORITY, and ENGINEER "as their respective interests may appear", subject to one hundred (100) percent co-insurance.

**Minimum Limits**

1.	Pollution Liability	\$1,000,000.00
----	---------------------	----------------

- K. The CONTRACTOR shall insure the structures, when applicable, and improvements against loss or damage by explosion, collapse and underground hazards, fire, windstorm, aircraft perils (extended coverage perils), vandalism and malicious mischief, during the progress of the work, and until final acceptance of the work by the AUTHORITY. Such insurance shall be written in **completed value form** for one hundred (100) percent of the completed value of the Project **including stored materials connected therewith**, with the amount to be certified to the CONTRACTOR by the ENGINEER.

L. The CONTRACTOR shall provide General Umbrella Liability with minimum limits of liability as follows:

**Minimum Limits**

1. General Aggregate	\$5,000,000.00
2. Each Occurrence	\$5,000,000.00

M. All policies will be subject to the approval of the AUTHORITY and ENGINEER.

N. Certificates of Insurance must be executed in quintuplicate and submitted to the ENGINEER prior to the execution of the Agreement. Certificates of Insurance will be required of all subcontractors documenting Workmen's Compensation Insurance coverage prior to performance of work on the site by subcontractors. The AUTHORITY shall be the certificate holder of all Certificates of Insurance and all Certificates of Insurance shall **name the AUTHORITY and the ENGINEER as co-insured (additional insured).**

O. Each certificate shall contain therein or have contained in a rider attached thereto and made a part thereof, a clause to the effect that the insurer will notify the AUTHORITY in writing thirty (30) days prior to cancellation or expiration of the policy.

P. The Surety on all bonds and insurance shall be rated "A" or better by A.M. Best Company and shall be licensed to conduct business in the Commonwealth of Pennsylvania.

**01010.1.12 DRAWINGS AND SPECIFICATIONS**

A. In general, the Drawings and Specifications are complementary; what is called for by one is as binding as if required by all. All items necessary or incidental to completely construct or erect the work denoted shall be furnished as required to provide a complete operating facility whether specifically detailed by the Drawings and/or Specifications.

B. Deviations from the Drawings or Specifications required by the exigencies of construction will be determined by ENGINEER only, and authorized in writing.

C. Where dimensions or locations of existing facilities are of importance to the successful performance of any part of the Work, CONTRACTOR shall verify the correctness of such dimension or location in the field before any other procedure, whether of manufacture of related equipment or construction of related structure, shall begin. Failure of CONTRACTOR to follow the required verification procedure here specified shall cause CONTRACTOR to waive all right to claim for additional cost by reason of the later discovery of inaccurate dimensions or locations of existing facilities as depicted on the Drawings and/or Specifications.

D. Drawings of the public water and/or sanitary sewer system facilities are to be submitted to the ENGINEER for approval and shall be drawn on sheets 24 inches by 36 inches to the following indicated scales:

- Key Sheet (index map) / Master Utility Plan: 1" = 100', or any convenient and legible scale that shows entire project on one 24" x 36" sheet, as approved by ENGINEER.

- Plan and Profile:
  - Horizontal 1" = 50'
  - Vertical 1" = 5'
  
- Detail Sheets: details shall be sized so text is legible

The AUTHORITY or the ENGINEER may require a change of scales, dependent on the size of the project.

1. The Key Sheet shall show the horizontal orientation of the project and the arrangement of plan and profile drawings. Pipe sizes shall be designated on the Key Sheet, by symbol or number, together with the names of all streets and the number designation of each sewer manhole. A vicinity map showing the entire development in relation to existing streets shall be provided on the Key Sheet. The scale of the vicinity map is optional.
  
2. The Master Utility Plan shall show all aboveground and underground utilities, including but not limited to sanitary, water, storm, electric, gas, cable, and telephone facilities and lot lines with finish floor elevations.

**Note:** The Key Sheet and the Master Utility Plan may be combined into one drawing if the requirements for both drawings can be fulfilled.

3. The Plan and Profile sheets show the detailed horizontal and vertical location of the proposed water and sewer system and their relation to existing and proposed facilities.
  - a. The Plan view shall indicate the horizontal location of all water and sewer facilities in relation to pertinent features. The size and material of all pipe, fittings, and appurtenances shall be labeled. Manholes shall be designated by numbers corresponding to the Key Sheet. Locations of each existing or proposed building shall be shown on the Plan with the elevation of the lowest finished floor and basement. The facilities shall have ties to existing permanent or semi-permanent features and shall be referenced to stationing for the centerline of the roadway, easement, or pipe. Stationing shall be shown on both the Plan and Profile views.
  
  - b. The Profile view shall indicate the vertical location of all water and sewer facilities in relation to pertinent features. The size and material of pipe, fittings, and appurtenances shall be labeled. For gravity sewers, the pipe distance between manholes, measured horizontally from center-to-center of the manholes, and the slope of each pipe shall be labeled. Manholes shall be designated by numbers corresponding to the Key Sheet, and the rim, invert in, and invert out elevations shall be labeled. All lateral service connections shall be shown and stationed along the sewer line with distance to and depth at right-of-way shown. The existing and proposed profile of the roadway ground surface shall be shown. Where other utilities cross the proposed pipeline, the size and invert elevations (top and bottom elevation in the case of duct lines) shall be given. Limits of concrete and polyethylene encasement shall be indicated, where appropriate.

4. Detail Sheets shall contain all applicable standard details, such as, but not limited to: bedding, encasement, thrust blocks, fire hydrants, valves, manholes, laterals, service connection, water and/or sanitary sewer system appurtenances, restoration, etc., included in these Specifications. Where reference is made herein in these Specifications to "Standard Detail" or "Detail", it shall be understood to mean the 8 ½" x 11" drawings in these Specifications.
- E. Drawings shall be neat and legible, without extraneous notes. Match lines shall be shown between separated plan views on the same sheet or on successive sheets. Lettering shall be oriented consistently. The ENGINEER may return any drawings for redrafting if it is determined that legibility is inadequate or if AUTHORITY drafting standards are not being met.

## **PART 2 - PRODUCTS**

### **01010.2.01 MATERIALS AND EQUIPMENT**

- A. All materials and equipment supplied for use on this project shall be new and purchased specifically for incorporation into the work included in the Drawings and Specifications, except as noted.
- B. CONTRACTOR shall furnish ENGINEER, promptly after the award or execution of the Agreement, a complete statement of the origin, composition, and manufacture of all materials to be used in the construction of the Project. Only materials conforming to the requirements of these Specifications and approved by ENGINEER shall be used in the work.
- C. Representative preliminary samples of the materials, of the character and quality prescribed in the Contract, shall be submitted when indicated or directed for advance examination or test. Written approval of the quality of such samples shall be received by CONTRACTOR prior to obtaining materials from the respective sources of supply.
- D. Samples of all materials requiring laboratory tests shall be taken under the direction or supervision of, or in the manner prescribed by ENGINEER. Such materials shall not be used until accepted as the result of such tests. Materials will be used only as long as the quality of the material remains equal to that of the accepted sample. The acceptance at any time of any material shall not be a bar to its future rejection, if it is subsequently found to be defective or inferior in quality to the material specified.
- E. Required laboratory tests of materials shall be made by a testing laboratory or agency selected or approved by ENGINEER and in accordance with the methods indicated herein. When standard specifications and serial numbers of technical societies and associations are stipulated, the reference shall be construed to be the latest of such specifications and serial numbers.
- F. CONTRACTOR shall furnish all labor, materials, and equipment necessary for collecting, packaging, and identifying representative samples of materials, and the shipping of such samples to the testing laboratory.

- G. For tests or inspections conducted by, and at the option of, ENGINEER, at sites other than the testing laboratory and not under the jurisdiction thereof, CONTRACTOR shall furnish or arrange with the producer to furnish all material, labor, tools, and equipment, and every facility for the verification of the accuracy of all scales, measures and testing equipment, necessary for such tests or inspections.
- H. CONTRACTOR shall permit or arrange with the producer to permit ENGINEER or any agent of the testing laboratory to inspect or test any and all material being used or to be used, at any time before, during, or after its preparation, or while being used during the progress of the work or after the work has been completed.
- I. Materials shall be stored so as to insure preservation of their specified quality and fitness for the work. When considered necessary they shall be placed on wooden platforms or other hard and clean surfaces, and not on the ground, and shall be placed under cover when directed. Stored materials shall be located so as to facilitate prompt inspection. Private property shall not be used for storage purposes without permission of the owner or lessee of the property.
- J. If any material intended for use in the construction of the Project has been inspected and rejected after such material has been delivered to the Site, all such rejected material shall be immediately removed from the property by CONTRACTOR.

#### **01010.2.02 PRODUCT DELIVERY, STORAGE AND HANDLING**

- A. Proper and suitable tools, equipment, and appliances for the safe and convenient handling and placing of all materials and equipment shall be used.
- B. During loading, unloading and placing, care shall be taken in handling the equipment and materials so that no equipment or materials are damaged.
- C. Any precautions necessary to protect items of equipment and materials from damage while stored on the construction site shall be exercised.
- D. All mechanical and/or electrical equipment and paint delivered to the job site shall be stored under roof, protected on all sides, and supported off the ground with pedestals. The resulting enclosure shall be weather tight in all respects.
- E. CONTRACTOR shall follow all written instructions and recommendations of the equipment manufacturer and all requirements of ENGINEER regarding the oiling, exercising, maintenance, and protection of the equipment during storage. It shall be CONTRACTOR's complete responsibility to satisfactorily store and care for equipment and materials.
- F. Equipment may be initially delivered to a warehouse, conveniently located in the vicinity of the site, with the approval of and under such conditions as may be further imposed by ENGINEER.

### **01010.2.03 PROTECTION AGAINST ELECTROLYSIS**

Where dissimilar metals are used in conjunction with each other, suitable insulation shall be provided between adjoining surfaces so as to eliminate direct contact and any resultant electrolysis. The insulation shall be bituminous impregnated felt, heavy bituminous coatings, non-metallic separators or washers, or other approved materials. When requested by ENGINEER, CONTRACTOR shall prove by acceptable test the effectiveness of the insulation.

## **PART 3 - EXECUTION**

### **01010.3.01 PRELIMINARY INSPECTION**

CONTRACTOR is required to carefully examine the site of the work, Drawings, Specifications, and all applicable State, County and local codes for the work contemplated; and it will be assumed that CONTRACTOR has familiarized and become satisfied as to the conditions and obstacles to be encountered, as to the character, quality, and quantities of work to be performed and materials to be furnished, and as to the requirements of the Drawings and Specifications.

### **01010.3.02 PRECONSTRUCTION MEETING**

- A. AUTHORITY or ENGINEER will schedule a conference prior to commencement of construction of the Work. This conference will normally include the DEVELOPER, CONTRACTOR(s), ENGINEER, and Resident Project Representative.
- B. Agenda for the Preconstruction Conference will include the following items as a minimum:
  - 1. Review the Scope of Work
  - 2. Designation of representatives for various parties
  - 3. Construction schedule submission
  - 4. Submittal requirements
  - 5. Escrow drawdown application procedures
  - 6. Inspection notifications
  - 7. Connection(s) to existing water and/or sanitary sewer systems
  - 8. Testing requirements
  - 9. Permit requirements/notifications
  - 10. Erosion control plan implementation
  - 11. Record Drawings
- C. CONTRACTOR is required to submit a construction schedule showing the order in which CONTRACTOR proposes to carry on the work, the dates on which they will start several of the more salient features and the contemplated dates for completing the same. The schedule shall be in the form of a progress chart of suitable scale as to approximately indicate the percentage of work completed at any time.

- D. A field visit of the construction area of the Work shall be conducted at the discretion of AUTHORITY or ENGINEER when it is determined to be necessary to observe pertinent conditions related to easements, right-of-ways, existing structures or obstructions and/or features to be removed, or changed.

**01010.3.03 PROGRESS MEETINGS**

- A. During the construction period, progress meetings shall be held with ENGINEER at the job site to discuss recent developments and future work plans as they relate to the schedule. Progress meetings will be held monthly in general, but the interval between meetings may be increased or decreased by ENGINEER to suit the current circumstances.
- B. AUTHORITY, ENGINEER, CONTRACTOR, and major Subcontractors shall be represented at every meeting by a responsible member of their respective organizations. All decisions and interpretations given by ENGINEER at project meetings shall be on behalf of AUTHORITY and shall be conclusive on CONTRACTOR and Subcontractors affected.
- C. The proceedings of these meetings will be recorded by ENGINEER, and each required representative at meetings will be furnished one copy. ENGINEER's act of conducting meetings, recording and distributing meeting minutes on behalf of AUTHORITY, shall not be construed as coordinating or scheduling CONTRACTOR's work.
- D. If a change of meeting date/time is required due to causes beyond control of AUTHORITY or ENGINEER, ENGINEER will advise each concerned party in advance of such change.

**01010.3.04 SHOP DRAWING SUBMITTALS**

- A. Shop drawings in this Specification are intended to mean fabrication and erection drawings. These drawings and pertinent data shall be complete and in such detail as ENGINEER may require for providing information regarding the design, installation, and operation for such materials and/or equipment.
- B. Detailed shop drawings, data, and literature for fabricated materials or equipment to be incorporated in the Project shall be submitted to ENGINEER for review before fabrication. CONTRACTOR shall obtain and check manufacturer's shop drawings, certified prints, and other pertinent data for conformance with all requirements of the Drawings and Specifications in ample time to permit satisfactory progress of the work. After completion of such checking and verification by CONTRACTOR, CONTRACTOR shall sign and stamp such drawings, which stamp shall state as follows:

Specification Section: \_\_\_\_\_

Checked By: \_\_\_\_\_  
(Contractor's Name)

Signed By: \_\_\_\_\_  
(Checker's Name)

- C. All data, drawings, and correspondence from subcontractors, material men, or suppliers shall be routed through CONTRACTOR. This procedure is required so that CONTRACTOR's superintendent can become familiar with all information which CONTRACTOR sends to ENGINEER and also to prevent ENGINEER from taking action upon something other than that which is desired by CONTRACTOR. ENGINEER shall consider for approval only such data and details as are verified and transmitted directly by CONTRACTOR. Failure of CONTRACTOR to note their approval on Shop Drawings will be reason for ENGINEER to return such submission to CONTRACTOR unchecked. If it appears that Shop Drawings submitted by CONTRACTOR to ENGINEER have not been properly checked, even though CONTRACTOR's approval has been noted thereon, it will also be considered reason for ENGINEER to return such submission to CONTRACTOR unchecked.
- D. All correspondence between ENGINEER and CONTRACTOR, all shop drawings, and all data for review of drawings or materials will be handled by ENGINEER. All such data shall be delivered directly to ENGINEER's office and accompanied by a letter of transmittal giving a list of the number of drawings. The replies pertaining to these matters will be delivered to CONTRACTOR's office or designated representative at the job site.
- E. A sufficient number of shop drawings and review data shall be submitted to ENGINEER, who will be allowed to retain five (5) copies of each submittal if it is electrical in nature and four (4) copies otherwise. All additional copies, up to a maximum of four (4), received by ENGINEER will be returned to CONTRACTOR or their representative at the job site. ENGINEER's notations of the action, which has been taken, will be noted on all the returned copies. Sufficient time for the review of all shop drawing submittals shall be allowed in CONTRACTOR's schedule.
- F. Drawings of minor or incidental fabricated materials and/or equipment may not be required by ENGINEER. CONTRACTOR shall furnish ENGINEER with tabulated lists of such fabrications, showing the names of the manufacturers and catalog numbers, together with samples of general data as may be required to permit intelligent determination as to their responsibility for incorporation in the work.
- G. The approval of shop drawings will be general and shall not relieve CONTRACTOR from responsibility for errors and discrepancies in such drawings and for proper fit and construction of the work; nor from furnishing materials and work required by the Contract, which may not be indicated on the shop drawings when approved.
- H. All review of shop drawings, data sheets and information, or literature is subject to the products fulfilling the specific requirements of the Drawings and Specifications. Review of items that do not conform in detail to the specified product shall place upon CONTRACTOR the entire responsibility for successful operation of the proposed product. Should the item subsequently prove to be defective or otherwise unsatisfactory for the service for which it was intended, CONTRACTOR shall, without cost to AUTHORITY and without obligation on the part of ENGINEER, replace the item with the material originally specified. ENGINEER's acceptance of shop drawings or layout for any material, apparatus, or device shall not relieve CONTRACTOR from the responsibility of furnishing the same of proper dimension, size, quantity, quality, and all performance characteristics to efficiently perform the requirements and intent of the Drawings and Specifications. Such review shall not relieve CONTRACTOR from responsibility for errors of any sort on the shop drawings. If the shop drawings deviate from the Drawings and

Specifications, CONTRACTOR shall advise ENGINEER of the deviations in writing accompanying the shop drawings, including the reasons for the deviations, and shall request a deviation from the Project Requirements as hereinafter described.

- I. The shop drawings are intended to be utilized by CONTRACTOR for additional fabrication, assembly, and erection data. The shop drawings do not change or supersede the Drawings and Specifications. CONTRACTOR's request for a change shall give, in detail, the specific change requested and shall state the reason for the change. Changes requested by CONTRACTOR and reviewed by ENGINEER shall not be construed to include acceptance of any change except the changed details specifically requested.
- J. It shall be the responsibility of CONTRACTOR to make all the necessary changes in other items, which result from deviations or changes requested by CONTRACTOR and accepted by ENGINEER, so that all items perform the requirements and intent of the Drawings and Specifications.

#### **01010.3.05 RESUBMITTALS**

- A. CONTRACTOR shall make resubmittals under procedures specified for initial submittals and shall identify changes made since previous submittals.
- B. Each resubmittal shall contain the original submittal number plus a suffix letter after the original number such as "A" for the first resubmittal, "B" for the second resubmittal, "C" for the third, and so forth.

#### **01010.3.06 CONSTRUCTION STAKEOUT**

- A. Construction stakeout shall be performed by CONTRACTOR. CONTRACTOR shall be responsible for protecting and preserving all reference points for the duration of the Project. Reference points for vertical control and all elevations shall be based on U. S. Geological Survey datum.

#### **01010.3.07 CONDUCT OF WORK**

- A. All work at the site shall normally be performed during regular working hours except as otherwise required for the safety or protection of persons, the Work, or property at or adjacent to the site. CONTRACTOR shall give prior notice to AUTHORITY and ENGINEER if performance of Work on an overtime basis or on weekends or legal holidays is requested and CONTRACTOR must receive written approval from AUTHORITY or ENGINEER prior to work.
- B. No work shall be done when, in the opinion of ENGINEER, the weather is unsuitable for good and careful work to be performed. Should the severity of the weather continue such that the Work cannot be prosecuted successfully, CONTRACTOR, under order of ENGINEER, shall cease all such work until directed to resume the same.
- C. CONTRACTOR shall arrange for and be responsible for a sufficient amount of illumination at all times, subject to the approval of ENGINEER, to carry on all phases of the work.

- D. All work shall be subject to the control of ENGINEER and AUTHORITY. In the performance of the work, CONTRACTOR shall abide by all orders, directions, and requirements of ENGINEER and AUTHORITY and shall perform all work in such manner and sequence as AUTHORITY may require. ENGINEER and AUTHORITY shall determine the amount, quality, acceptability, and fitness of all parts of the work; shall interpret the Drawings and Specifications; and shall decide all other questions in connection with the Work. CONTRACTOR shall employ no equipment, materials, or methods to which ENGINEER or AUTHORITY objects and shall remove no materials, equipment, or other facilities from the site of the Work without permission of ENGINEER or AUTHORITY. Upon request, ENGINEER or AUTHORITY shall confirm in writing, any oral order, direction, requirement, or determination. If any person employed on the Work by CONTRACTOR shall appear to ENGINEER or AUTHORITY to be incompetent or to act in a disorderly or improper manner, such person shall be removed immediately upon request by ENGINEER or AUTHORITY.
- E. CONTRACTOR agrees to use, at all times on the work, only such labor as will in no way disturb or affect labor employed by AUTHORITY and/or other contractors on the project. CONTRACTOR and each and every subcontractor performing work at the site of the project shall comply with all "Labor Laws" of the Government, and of the State, County, and Township in which the project is located.

#### **01010.3.08 CONTRACTOR'S PERSONNEL**

- A. CONTRACTOR shall keep a competent and reliable resident superintendent on the Project at all times during its progress. This individual will be CONTRACTOR's representative at the site of the Work and shall have authority to act on behalf of CONTRACTOR.
- B. CONTRACTOR shall make available at all times, including nights, weekends, and holidays, an emergency maintenance crew and a person of authority and responsibility to act in cases of emergency such as flooding, cave-ins, etc., resulting from construction associated with the Work. CONTRACTOR shall submit to DEVELOPER and AUTHORITY, the names and location of emergency personnel prior to the start of construction.
- C. CONTRACTOR shall provide competent, suitably qualified personnel to construct the Work as required by these Drawings and Specifications. CONTRACTOR shall at all times maintain good discipline and order at the site. CONTRACTOR shall remove any employees found under the influence of drugs or alcohol from the site.

#### **01010.3.09 SAFETY REQUIREMENTS**

- A. CONTRACTOR shall furnish, erect and maintain at closures, intersections and throughout the Project, all necessary approved barricades, suitable and sufficient red lights, torches, approved reflectors, danger signals, warning, and closure signs, provide a sufficient number of watchmen and take all necessary and legal precautions for the protection of the Work and safety of the public. All barricades, danger signals, warning signs and obstructions shall be illuminated at night and all lights shall be kept burning from sunset until sunrise. All materials and safety devices (i.e., barricades, flashing warning, torches, reflectors, and signs) which CONTRACTOR provides for the purpose of protecting the Work and the safety of the public and for maintaining and protecting traffic must conform to the requirements specified in

Section 901 of the current edition of the Commonwealth of Pennsylvania Department of Transportation Specifications Publication 408, as supplemented and to the requirements specified in the current edition of PA Code Title 67, Transportation Chapter 213 - Work Zone Traffic Control, which complements Sections 901.

- B. The safety provisions or applicable laws, and regulations of the Pennsylvania Department of Labor and Industry, and building and construction codes shall be observed. Machinery, equipment, and other hazards shall be guarded in accordance with the safety provisions of the "Manual of Accident Prevention in Construction", published by the Associated General Contractors of America, to the extent that such provisions are not in contradiction of applicable state and local laws.
- C. Observance of, and compliance with, said regulations shall be solely and without qualification, the responsibility of CONTRACTOR, without any responsibility whatsoever on the part of AUTHORITY or ENGINEER. The duty of enforcing such laws and regulations lies with the said Department, not with AUTHORITY or ENGINEER.
- D. The provisions of the "OCCUPATIONAL SAFETY AND HEALTH ACT OF 1970" of the U.S. Department of Labor shall be complied with in the performance of the Work. Observance of, and compliance with, said Act shall be solely and without qualification the responsibility of the CONTRACTOR, without reliance on superintendence of, or direction by, AUTHORITY or ENGINEER. The duty of enforcement of the provisions of the Act lies with the U.S. Department of Labor, not with AUTHORITY or ENGINEER.

#### **01010.3.10 PROTECTION OF PUBLIC AND PRIVATE PROPERTY**

- A. CONTRACTOR shall take all necessary precautions to protect and prevent damage to overhead and underground utilities, structures, streets and driveways, culverts, street signs, fences, trees/shrubs, property markers, pins/monuments and other existing features within or adjacent to the area of the Work.
- B. CONTRACTOR shall comply with the requirements of PA Act 287, December 10, 1974, as last amended, with regard to underground utilities prior to performing excavation or demolition activities.
- C. CONTRACTOR shall be responsible for damage to public and private property and shall restore any damaged property to a condition at least as good as which existed prior to construction.
  - 1. All curbs, gutters, and sidewalks damaged or disturbed shall be replaced with the same type of materials, as the original curb, gutter, or sidewalk. The replaced curbs, gutters and sidewalks shall be of the same shape, thickness and surface finish as the original curb, gutter or sidewalk.
  - 2. All driveways shall be restored to a condition equal to their complete original undisturbed condition, using the same type and quality of materials as that of the particular driveway restored.

- D. CONTRACTOR shall videotape with accompanying narrative, any off-site construction Work areas along rights-of-ways or easements prior to construction. This shall include any private property adjacent to the Work areas (to be recorded without entering said private property).
- E. CONTRACTOR shall protect all property markers, pins and monuments to be affected by construction until they have been properly referenced. Any disturbed property markers, pins and/or monuments shall be correctly reset following construction activities.
- F. CONTRACTOR shall take special care to avoid interference with the operation of any existing utilities. Of particular concern are any proposed connections to AUTHORITY's existing water distribution and/or sewage collection system. A sequence of construction relative to any connection to AUTHORITY's water system and/or sanitary sewerage system shall be reviewed with and approved by ENGINEER prior to construction of any connection, which impacts upon operation of AUTHORITY's existing system.

#### **01010.3.11 BLASTING REQUIREMENTS**

- A. Blasting will be permitted except in areas where the proximity of structures, underground facilities, or public safety precludes the use of explosives. CONTRACTOR shall observe the utmost care in the use of explosives so as not to endanger life or property. Nothing in this section shall relieve CONTRACTOR of the responsibilities for damages, nor shall it result in any responsibility to AUTHORITY or ENGINEER.
- B. DEVELOPER/CONTRACTOR shall comply with all local, State and Federal laws relating to the transportation, storage, handling, and use of explosives, blasting agents and caps.
- C. Blasting requirements are more completely addressed elsewhere in these specifications; the following requirements are among those imposed on DEVELOPER/CONTRACTOR.
  - 1. Obtain permit from Township.
  - 2. Obtain permit from PennDOT relative to any predrilling and/or blasting within the State highway right-of-way.
  - 3. Submit any blasting bonds, insurance certificate (public liability and property damage), or other financial security required by Township, PennDOT or other involved governmental agency.
  - 4. Conduct a Preblasting Survey of nearby buildings relative to structural conditions and water supply wells.

#### **01010.3.12 TRAFFIC CONTROL**

- A. CONTRACTOR must maintain safe and efficient movement of traffic in the vicinity of construction. All work pertaining to traffic control is to be performed by the CONTRACTOR at no additional cost to AUTHORITY.

- B. CONTRACTOR shall implement the Traffic Control Plan and any associated requirements as approved by PennDOT's Highway Occupancy Permit and/or the Township's Road Opening Permit relative to Work in and along Highways and Streets.
- C. CONTRACTOR shall furnish, erect, and maintain traffic cones, drums, barricades, flashing danger signal lights, directional signs and provide trained and equipped flagmen as required by the Traffic Control Plan and State and local permit requirements to restrict the movement of traffic within the construction areas and to clearly indicate the restrictions well in advance to vehicular traffic. (See Section 01010.3.09 SAFETY REQUIREMENTS).
- D. CONTRACTOR shall consult with authority having jurisdiction in establishing public thoroughfares to be used for haul routes and public access.
- E. CONTRACTOR shall provide advance notification to any parties so noted in PennDOT's Highway Occupancy Permit or Township's Road Opening Permit in accordance with the required time schedule. In any event, the local Police Department shall be notified at least ten (10) days prior to the date CONTRACTOR desires to restrict traffic in or along any highways or roads.
- F. Roads shall not be unnecessarily obstructed and unless the CONTRACTOR has been authorized in writing, shall not completely close the road and shall take such measures as may be necessary to keep the road open and safe for traffic.
- G. CONTRACTOR shall obtain advance approval from the ENGINEER and the authority having jurisdiction (PennDOT, Township, Borough or County) should it be necessary to temporarily close a road. The CONTRACTOR shall notify the following parties at least twenty-four (24) hours in advance.
  - 1. Township/Borough Police
  - 2. Local Fire Company
  - 3. Local School District
  - 4. Local Ambulance Service
  - 5. All affected residents
- H. For any road closure, CONTRACTOR shall provide proper and adequate detour routes and signage. The detour plan must be approved by the State and/or Municipality, and AUTHORITY prior to road closure. At least one lane must be open for traffic during non-working periods and CONTRACTOR must be prepared to allow passage of emergency vehicles at any time.
- I. At the shutdown of work at the end of the workday, all streets shall be left in such condition whereby they can be readily opened and safely traveled in cases of emergency such as a fire or for ambulance service.
- J. Storage of all materials, equipment, machinery, tools, etc. is the CONTRACTOR's responsibility. The CONTRACTOR is prohibited from storing any and all materials, equipment, machinery, tools, etc. on streets, shoulders, sidewalks, etc. All items must be stored and parked within the provided easement in unimproved areas.

- K. CONTRACTOR shall control parking of construction equipment and construction personnel vehicles to prevent interference with public traffic and parking access by emergency vehicles and AUTHORITY's operations.
- L. CONTRACTOR shall prevent parking on or adjacent to public streets or in non-designated areas unless prior approval is obtained from the Municipality.
- M. CONTRACTOR shall not obstruct access to fire hydrants.
- N. Access must be maintained at all times during non-working periods and to the maximum extent feasible during working periods to all driveways and entrances of adjacent properties. In this regard, the construction and maintenance of temporary steel plates or other decking across the trench may be necessary to reduce to a minimum interference with access to the adjacent properties.
  - 1. With PADOT and Township/Borough approval, open trenches in or along highways or roads shall be safely decked during non-Work periods by the use and maintenance of steel plates or other decking, which shall have sufficient strength to safely support all traffic including truck loads.
- O. When the work, including repaving, has been completed, the temporary measures of the Traffic Control Plan shall be removed, any damage caused by installation of the temporary measures shall be repaired, and traffic shall be restored to its former condition.

### **01010.3.13 TEMPORARY FACILITIES**

- A. CONTRACTOR shall furnish and maintain all temporary telephone, gas, electric, water, and sewer utilities required for construction, start-up, and performance testing of the Project. All costs for providing temporary utilities shall be borne by CONTRACTOR up to and including the date of acceptance. CONTRACTOR is not required to provide field facilities for ENGINEER.
- B. CONTRACTOR shall furnish and erect all necessary temporary fences required to provide adequate security for all materials, equipment, and structures throughout the project.

### **01010.3.14 CLEANING UP**

- A. Continuously keep the work, the site, and adjacent properties free from accumulations of waste materials, excess excavation, rubbish, and windblown debris resulting from construction operations. Periodically remove waste materials, excess excavation, debris, and rubbish from the site and dispose of at legal disposal areas away from the project site.
- B. Remove grease, mastics, adhesives, dust, dirt, stains, fingerprints, labels, and other foreign materials from site-exposed interior and exterior surfaces of structures. Broom clean exterior paved surfaces; rake clean other surfaces of the grounds. Restore areas disturbed by construction. Provide continuous dust control during construction.

- C. At the completion of the work, or each major portion thereof, CONTRACTOR shall remove surplus materials, tools, construction equipment and machinery, and leave the site clean and ready for occupancy by AUTHORITY.

### **01010.3.15 TESTS AND INSPECTIONS**

- A. In addition to all other tests and inspections required by these specifications, an audio-videotape of the inside of all sanitary sewer lines shall be submitted to AUTHORITY. Refer to Specification Section 02650 for detailed requirements.
- B. AUTHORITY, ENGINEER, Resident Project Representative, and other representatives and personnel of AUTHORITY, independent testing laboratories and governmental agencies with jurisdictional interests will have access to the Work at reasonable times for their observation, inspecting and testing. CONTRACTOR shall provide them proper and safe conditions for such access and advise them of CONTRACTOR's site safety procedures and programs so that they may comply therewith as applicable.
- C. CONTRACTOR shall give ENGINEER timely notice of readiness of the Work for all required inspections, tests or approvals, and shall cooperate with inspection and testing personnel to facilitate required inspection tests.
- D. CONTRACTOR shall pay for all tests required as set forth in the Specifications.
- E. If any Work that is to be inspected, tested, or approved is covered by CONTRACTOR, it must, if requested by ENGINEER, be uncovered for observation. Uncovering Work (and repairing/replacing any defective Work) shall be at CONTRACTOR's expense.

### **01010.3.16 STARTUP OF MECHANICAL and/or ELECTRICAL EQUIPMENT/SYSTEMS**

- A. CONTRACTOR shall make a request in writing at least ten (10) days in advance of starting each operational acceptance test. Such tests shall be conducted with qualified representatives of the equipment manufacturer present, and in accordance with the requirements of these Specifications. All pertinent Operation and Maintenance manuals must be in receipt of ENGINEER prior to any operational acceptance test.
- B. After installation, the CONTRACTOR shall adjust and balance all equipment and systems, and shall demonstrate that all equipment is operating in a satisfactory manner. All rotating equipment shall be lubricated according to recommendations of the manufacturers and shall be made to suit anticipated operating conditions. Each piece of machinery shall be tested to show that it operates quietly, without vibrations, overheating, or sign of distress at full specified capacity. Adjustments shall be made as necessary. All defective parts on machinery shall be replaced.
- C. CONTRACTOR shall insure that each piece of equipment or system is ready for operation and execute start-up under supervision of manufacturer's authorized representative in accordance with manufacturers' instructions. Operative products and equipment shall be adjusted to insure smooth and unhindered operation. All defective parts or machinery shall be replaced by CONTRACTOR at CONTRACTOR's expense.

- D. CONTRACTOR shall submit a written installation certificate, signed by CONTRACTOR and by manufacturer's representative, that equipment or system has been properly installed and is functioning correctly.
- E. CONTRACTOR shall demonstrate operation and maintenance of equipment to AUTHORITY's personnel two (2) weeks prior to date of final inspection. This demonstration shall include start-up, operation, control, adjustment, troubleshooting, servicing, maintenance, and shutdown of each item of equipment at equipment location. For equipment or systems requiring seasonal operation, the demonstration for the other season(s) shall be performed within six (6) months.
- F. All parts and components of mechanical equipment shall be designed for satisfactory service under continuous duty without wear under the specified and indicated operating conditions for a period of not less than one (1) year, unless otherwise noted for specific equipment elsewhere in these specifications. Any part of mechanical equipment that shows undue or excessive wear or that fails due to wear under normal operating conditions within the first year of operation under operational acceptance shall be considered as evidence of defective material or defective workmanship, and it shall be replaced with equipment or parts to meet the specified requirements.

#### **01010.3.17 DEFECTIVE WORK**

- A. Prompt notice of all defective Work of which AUTHORITY or ENGINEER have actual knowledge will be given to CONTRACTOR. All defective Work may be rejected, corrected or accepted as provided in this section.
- B. If Work is defective, or CONTRACTOR fails to supply sufficient skilled workers or suitable materials or equipment, or fails to furnish or perform Work in such a way that the completed Work will conform to the Drawings or the Specifications, AUTHORITY may order CONTRACTOR to stop Work, or any portion thereof, until the cause for such order has been eliminated; however, this right of AUTHORITY to stop Work shall not give rise to any duty on the part of AUTHORITY to exercise this right for the benefit of CONTRACTOR or any surety or other party.
- C. If required by ENGINEER, CONTRACTOR shall promptly, as directed, either correct all defective Work, whether or not fabricated, installed or completed, or, if the Work has been rejected by ENGINEER, remove it from the site and replace it with Work that is not defective. CONTRACTOR shall pay all claims, costs, losses, and damages caused by or resulting from such correction or removal (including but not limited to all costs or repair).

- D. If within one year after the date of acceptance any Work is found to be defective, CONTRACTOR shall promptly without cost to AUTHORITY and in accordance with AUTHORITY'S written instruction: (i) correct such defective Work, or, if it has been rejected by AUTHORITY, remove it from the site and replace it with Work that is not defective, and (ii) satisfactorily correct or remove and replace any damage to other Work or the worth of others resulting therefrom. If CONTRACTOR does not promptly comply with the terms of such instructions, or in an emergency where delay would cause serious risk of loss or damage, AUTHORITY may have the defective Work corrected or the rejected Work removed and replaced, and all claims, costs, losses and damages caused by or resulting from such removal and replacement (including but not limited to all costs or repair or replacement of Work of others) will be paid by CONTRACTOR.

In special circumstances where a particular item of equipment is placed in continuous service before AUTHORITY accepts the Work, the correction period for that item may start to run from an earlier date as established by ENGINEER.

Where defective Work (and damage to other Work resulting there from) has been corrected, removed or replaced under this paragraph, the correction period hereunder with respect to such Work will be extended for an additional period of one (1) year after such correction or removal and replacement has been satisfactorily completed.

- E. If, instead of requiring correction or removal and replacement of defective Work on the Project, AUTHORITY prefers to accept it, AUTHORITY may do so. CONTRACTOR shall pay all claims, costs, losses, and damages attributable to AUTHORITY'S evaluation of and determination to accept such defective Work (such costs to be approved by ENGINEER as to reasonableness).

### **01010.3.18 OPERATION AND MAINTENANCE MANUALS**

- A. CONTRACTOR shall initially furnish four (4) copies of a complete instruction manual for installation, operation, maintenance, and lubrication of each component of mechanical and electrical equipment. All copies shall be submitted to ENGINEER for review and comment. Each instruction manual furnished shall be bound in 8-1/2 x 11 inch text pages, three ring binders with durable plastic covers. CONTRACTOR shall revise contents of manual as required based on ENGINEER'S comments and submit four (4) copies of revisions within 15 days thereafter.
- B. Binder cover shall be prepared with printed title "OPERATION AND MAINTENANCE MANUAL", and title of Project Binder contents shall be internally subdivided with permanent page dividers, logically organized, with tab titling clearly printed under reinforced laminated plastic tabs.
- C. Each operation and maintenance manual shall be transmitted to ENGINEER according to the established schedule and prior to installation of the equipment and all equipment shall be serviced in accordance with the manufacturer's recommendations prior to operation. A service record shall be maintained on each item of equipment and shall be delivered to ENGINEER prior to final acceptance of the project by AUTHORITY.

- D. Each operation and maintenance manual shall include a directory, listing names, addresses, and telephone numbers of CONTRACTOR, subcontractors, and major equipment suppliers.
- E. Each operation and maintenance manual shall include but not be limited to the following: detailed description of the function of each principal component of the system; installation instructions; procedure for starting; procedure for operating; shutdown instructions; maintenance and overhaul instructions which shall include detailed assembly drawings with part numbers, parts list, and complete instructions for ordering spare parts; lubrication instructions which shall list points to be greased or oiled, and recommend frequency of lubrication; safety precautions, diagrams and illustrations; test procedures; and performance data. It is intended that the manual shall be complete in all respects for all equipment, controls, accessories, and associated appurtenances.
- F. Each operation and maintenance manual shall include installation certificates, and warranties associated with the Work.
- G. Operating instructions for use by operating personnel shall be provided for each principal equipment component. The instructions shall be placed adjacent to the applicable equipment and shall be protected against weathering with a laminated plastic coating. The instructions shall include but not be limited to the following: start-up, proper adjustment, operation, shutdown, safety precautions, procedure in event of equipment failure, and any other necessary items of instruction as recommended by the manufacturer of the unit.

#### **01010.3.19 RECORD DRAWINGS**

- A. CONTRACTOR shall maintain on-site, one (1) copy of Drawings on which shall be recorded all field changes concurrent with construction progress to accurately show the "as-built" conditions of the constructed Work.
- B. Prior to acceptance of the Work by the AUTHORITY, the DEVELOPER shall provide to the AUTHORITY a set of reproducible drawings showing the "as-built" conditions of the constructed Work. Each drawing shall be noted as a Record Drawing and dated along with a certification letter from DEVELOPER/CONTRACTOR stating that the Record Drawings represent a true and accurate record of the constructed Work (AUTHORITY intends to use prints of the reproducibles to provide information to designers and contractors as required by the Commonwealth of Pennsylvania Act 287). Two paper copies shall first be submitted to ENGINEER for review and comment. After all appropriate Record Drawings are reviewed and approved by ENGINEER, three (3) paper copies (signed and sealed) and one (1) PDF copy (signed and sealed) of each drawing shall be submitted to AUTHORITY. A digital AutoCAD electronic file shall also be provided of all Record Drawings, in AutoCAD 2019 format.
- C. All as-built features shown on Record Drawings shall be surveyed by Registered Professional Surveyor, licensed to practice in the Commonwealth of Pennsylvania. All as-built Electrical Drawings shall be sealed by a Registered Professional Engineer, licensed to practice in the Commonwealth of Pennsylvania. Each paper copy of Drawings shall have the original seal and signature of the Registered Professional Surveyor and/or Engineer responsible for the specific Drawing.

D. The Record Drawings shall incorporate but not necessarily be limited to the following as-built features:

1. Sanitary Sewer Project

- Lateral locations (stationing, offset to R-O-W or easement, and stationing for each lateral/main connection from nearest downstream manhole shall be given in profile view or chart form)
- Lateral cleanout locations (with survey ties to front corners of building, with symbol shown at as-built location)
- Manhole data (symbol shown at as-built location, rim & invert elevations) Original design information relating to rim and invert elevations shall be crossed out and as-built information shall be added in parentheses.
- As-built plan and profile of sewer. Original design information relating to size, material, length, and slope of gravity sewers shall be crossed out and as-built information shall be added in parentheses.
- Concrete encasements (location & length)
- Utility locations
- Location of sewers and manholes within easements

2. Water and/or Sanitary Sewage Force Main Project

- Horizontal and vertical alignment of force main,
- Size and material of force main,
- Valve locations,
- Special chambers (meter, air release/vacuum, cleanout). Original design information relating to rim and invert elevations shall be crossed out and as-built information shall be added in parentheses,
- Depth of cover over force main,
- Location of force mains within easements,
- Water service and/or lateral connection to main locations (with stationing, offset to R-O-W or easement)
- Curb stop/box and/or lateral cleanout locations (with stationing, offset to R-O-W or easement and survey ties to front corners of building, with symbols shown at as-built locations)
- As-built plan and profile of water and/or sewer facilities. Original design information relating to size and material shall be crossed out and as-built information shall be added in parentheses.
- Concrete encasements (location & length)

- Utility locations
- Location of water and sewer mains and appurtenances within easements.

### 3. Pumping Station or Treatment Facilities

- Internal building as-built conditions, including electrical, plumbing, HVAC and mechanical process equipment
- Survey location, dimensions and elevations of manholes (including rim & invert elevations), buildings (including finished floor elevations), subsurface utilities (including depth), wet wells and chambers (including top slab, inside bottom and pipe centerline elevations),
- Survey location of site features including well heads, paved areas, utility poles, equipment and equipment pads, fence, gates, trees and shrubs,
- Surveyed as-built topographic features, using same elevation datum used for original plan submission,
- Location and size of electrical/communication conduits.

#### **01010.3.20 TWELVE MONTHS RESPONSIBILITY**

DEVELOPER agrees to furnish such material and appliances, and to construct the whole work in such substantial and workmanlike manner that it shall be continuously stable and efficient, and CONTRACTOR shall promptly make good, or replace, any or all parts of the materials or installation, including all details, which may be found to be unstable or defective in any particular, ordinary wear and tear excepted, for a period of guarantee of twelve (12) months after the whole installation has been entirely completed, tested and accepted by AUTHORITY, except that a period of guarantee of two (2) years after acceptance by Pennsylvania Department of Transportation shall apply for restoration work within a State Highway right-of-way. See Appendix B for the Maintenance Bond form.

#### **01010.3.21 TWELVE MONTHS RESPONSIBILITY NOTWITHSTANDING INSPECTION**

The acceptance, after inspection by ENGINEER, or their representative, of any portion of the work or material, shall be subject to its freedom from the exhibition of any inherent or developed defect, or any failure to conform to these Specifications, between the time of its acceptance, and the expiration of the above named period of twelve (12) months (two (2) years within a State Highway right-of-way).

#### **01010.3.22 DEDICATION**

- A. Developers requesting dedication of water and sanitary sewer facilities shall notify the Bucks County Water & Sewer Authority in writing of their intent to dedicate facilities.
- B. The following information is required for dedication of DEVELOPER constructed water and/or sanitary sewer facilities to AUTHORITY:

1. Working Punchlist - Prior to final road paving the ENGINEER shall review the condition of the subject facilities and prepare a "Working Punchlist". All testing of water and/or sanitary sewer facilities shall be completed and approved prior to final paving. Final Paving shall not be completed until a working punchlist has been prepared and all facilities within the roadway have been repaired to the satisfaction of ENGINEER.
2. Final Punchlist - After final road paving, the ENGINEER will prepare a "Final Punchlist". All items on Final Punchlist shall be completed and approved by ENGINEER prior to dedication.
3. Legal Descriptions shall be submitted to AUTHORITY for the following:
  - Land with facilities to be transferred directly to AUTHORITY.
  - Blanket easements for water and/or sewer facilities being conveyed to the Authority that are located in public right-of-ways.
  - Utility easements for water and/or sewer facilities being conveyed to the AUTHORITY.

All Legal Descriptions shall have an attached sketch detailing the area described. Sketch shall be 8.5" x 11" or 11" x 17" foldout and shall have described area highlighted. After legal descriptions and sketches are reviewed and approved by ENGINEER, three (3) copies of each (with original seal/signature) shall be submitted to AUTHORITY.

4. Record Drawings shall be submitted to and approved by AUTHORITY and ENGINEER. Paper copies, PDF's on CD or portable storage drive, and digital AutoCAD electronic files shall be provided in accordance with this specification.
- C. Prior to dedication, a televised recording of the inside of all sanitary sewer lines shall be submitted to the ENGINEER for review and approval. Refer to specification Section 02650 for detailed requirements.
- D. At the time of dedication, a maintenance bond shall be submitted to the AUTHORITY in an amount as specified by the ENGINEER and in a form satisfactory to the AUTHORITY Solicitor.

**END OF SECTION**

**SECTION 01015  
DESIGN STANDARDS AND SPECIAL REQUIREMENTS**

**PART 1 – GENERAL**

**01015.1.01 WATER SYSTEM DESIGN STANDARDS**

- A. Water systems, which are to be dedicated to the AUTHORITY, shall be designed, constructed, inspected, and tested at the DEVELOPER's expense. The water system design shall be submitted to the AUTHORITY for ENGINEER's review and AUTHORITY's approval. The ENGINEER shall inspect the construction and testing Work. The design shall be in accordance with the standards herein and the review comments of the ENGINEER. Undedicated water systems shall not be permitted to connect to the AUTHORITY's water system.
- B. All water mains and services shall be constructed with a minimum 4-foot Depth of Cover.
- C. No main shall be installed without the presence of either curb or grade stakes used as control.
- D. All distribution systems shall be looped. Mains shall be extended to the outer limits of the development parcel for connection to existing mains or possible future mains.
- E. All mains must be located in the public right-of-way or an easement dedicated to the AUTHORITY.
- F. Fire Hydrants shall be provided on all proposed mains and be approved by the local Township/Borough Fire Marshal. Hydrants shall be spaced no more than 600 feet apart. Hydrants shall be placed at the following additional locations:
  - 1. Near the base of each water storage reservoir or tank,
  - 2. At all high points where air valve is not required,
  - 3. At all low points with a blow off tee (tangent) on the main,
  - 4. Within 400 feet of all structures except where permitted otherwise by Local ordinance.
  - 5. As required by Township/Borough Fire Marshal.
- G. Pipe deflection at the joint may be permitted upon the approval of the ENGINEER. The deflection cannot exceed half of the pipe manufacturer's maximum allowable deflection, but in no case shall be greater than two degrees.
- H. All water mains shall be designed in accordance with the latest edition of the Pennsylvania Department of Environmental Protection's "Public Water Supply Manual" and the latest applicable AWWA Standards.
- I. Isolation gate valves shall be provided on all branch lines and on continuous runs of pipe at a maximum spacing of 800 feet.
- J. The minimum residual water pressure during peak flow or fire flow shall be 20 psig.

- K. Fire flow rates shall be a minimum of 1,000 gallons per minutes for two hours or greater, as required by local ordinances, and/or I.S.O. requirements.
- L. The minimum water main pipe size shall be 8” diameter. A special request will need to be made to AUTHORITY/ENGINEER for use of a smaller main.
- M. Each parcel shall have its own water service line and shall be connected to the water main with a corporation stop and a curb shut off valve with a valve box. See Detail W-1 and W-2.
- N. Each service line shall have a meter with backflow preventer installed in the house. See Detail W-8.
- O. All dead ends, fittings, and fire hydrants shall be provided with both mechanical restraint and concrete thrust block, which shall be independently designed to restrain the pipe.
- P. Mains shall be designed to pass over sanitary sewers and sanitary laterals with a minimum clearance of eighteen (18”) inches.

#### **01015.1.02 PUBLIC WATER WELL DESIGN STANDARDS**

- A. Well sites and water supply facilities, which are to be dedicated to the AUTHORITY, shall be designed, constructed, inspected, and tested at the DEVELOPER’s expense. The design shall be in accordance with the standards herein and PADEP Public Water Supply Manual. The ENGINEER shall inspect the construction and testing. Undedicated water systems shall not be permitted to connect to the AUTHORITY’s water system.
- B. The DEVELOPER shall provide adequate land, access, and facilities to be dedicated to the AUTHORITY, suitable for the development and operation of the well site for public water supply.
- C. A Predesign Conference with OWNER and ENGINEER is mandatory to discuss all of the design requirements including but not limited to the production wells, chlorination, storage tank, monitoring wells, wellhead protection easements, hydrogeologic report, pumping systems, control building, standby emergency generator, permitting, etc.
- D. OWNER reserves the right to require that their ENGINEER design the public water well facilities, the cost of which to be borne by the DEVELOPER.

#### **01015.1.03 SANITARY SEWER SYSTEM DESIGN STANDARDS**

- A. Sanitary sewer systems, which are to be dedicated to the AUTHORITY, shall be designed, constructed, inspected, and tested at the DEVELOPER’s expense. The sanitary sewer system design shall be submitted to the AUTHORITY for ENGINEER’s review and AUTHORITY’s approval. The ENGINEER shall inspect all sanitary sewer related construction and testing. The design shall be in accordance with the standards herein and the review comments of the ENGINEER. Undedicated, metered sanitary sewer systems, if approved by the AUTHORITY, may be permitted to connect to the AUTHORITY’s sewer system, as long as they were constructed in accordance with these Specifications.

- B. Large projects, or other projects of special concern as determined by the AUTHORITY, shall provide a metering system to measure gravity sewer flows emanating from the project. The flow metering system shall be arranged by AUTHORITY's Metering Consultant or approved equivalent with costs for setup, installation and ongoing maintenance borne by DEVELOPER.
1. For proposed Developments consisting of 25 EDU's or greater, it is required that flow meter data be available within the prior 5 years for the receiving sanitary sewers and facilities. The flow data will be utilized to characterize the existing peak flow in those sewers/facilities, and once the proposed peak flow from the Development is added to the existing peak, the resulting value will be used to determine if the existing receiving sewers/facilities require upgrades. If it is determined that an upgrade is required, that work shall be incorporated into the Development project. Should the Authority not have any available flow meter data for the receiving sewers/facilities within the prior 5 years, it shall be the Developer's responsibility to pay for the installation of a temporary flow meter(s) at locations selected by the Authority and their Engineer to satisfy this requirement. The flow meter(s) must remain in place long enough to capture a significant wet weather event that produces an accurate peak flow.
- C. All sanitary sewer facilities shall be designed in accordance with the latest edition of the Pennsylvania Department of Environmental Protection's "Domestic Wastewater Facilities Manual" and the latest applicable 10-States Standards "Domestic Wastewater Facilities Manual, and these Specifications.
- D. Ductile iron pipe or PVC may be used for sanitary sewers that are outside of roadway right-of-ways (in easements). However, in areas of high groundwater (flood plains, stream crossings, and wetlands) ENGINEER may require the use of ductile iron pipe only. In addition, where depth to crown of sewer from finished grade is greater than twelve (12) feet, only ductile iron pipe shall be used. Change of pipe material between manholes will not be permitted.
- E. The minimum sewer main pipe size shall be eight-inches (8") in diameter and the minimum lateral pipe size shall be six-inches (6") in diameter from the main sewer to the right-of-way line or edge of easement.
- F. The minimum slope of an eight-inch (8") diameter sewer shall be 0.005 ft/ft except for terminal manhole runs, which shall be a minimum of 0.01 ft/ft. Maximum lateral length shall be 50-feet measured from the sewer main connection to the property line unless otherwise approved by the ENGINEER. The minimum allowable lateral slope shall be 0.02 ft/ft.
- G. Each parcel shall have its own sanitary sewer service lateral and shall be connected to the sewer main with a wye or tee-wye fitting.
- H. Each service lateral shall have a cleanout provided at the edge of the public right-of-way or easement. See Detail S-9 and S-10.
- I. No sanitary sewer shall be located closer than ten (10) feet to a property line or easement line.
- J. The maximum allowable distance between manholes shall be 350 feet.

- K. No lateral connections shall be made directly to manholes unless approved by the ENGINEER. Manholes which are approved to have laterals tie into them must be constructed with six-inch (6") "A-Lok" type connection at the manhole base. A channel from the lateral pipe to the effluent pipe must be constructed in the base.
- L. The Specifications for the Sewage Pumping Station are for a typical submersible pumping station and lack sizes and capacities. There may be circumstances where a wet well/dry well type pumping station is more appropriate. The AUTHORITY should be consulted prior to initiating design regarding the type of pumping station, sizes, capacities, and emergency power requirements for the project. The DEVELOPER shall submit to the ENGINEER for approval prior to the start of any construction, specifications and drawings of the pumping facility giving complete dimensions, sizes, capacities, loads, electrical wiring, description and quality of materials, etc.
- M. When sanitary sewer pumping stations or low pressure sewage systems are being considered, see Specification Sections 11306 and 02735 for additional design criteria.
- N. All sanitary force main fittings shall be provided with both mechanical restraint and concrete thrust block, which shall be independently designed to restrain the pipe.
- O. Sanitary sewer mains shall be extended to the outer limits of the development parcel where practical to allow existing residents to connect or for possible future connection to the main.
- P. All sanitary sewer mains to be dedicated must be located in the public right-of-way or an easement dedicated to the AUTHORITY.
- Q. Sanitary sewer mains and laterals shall be designed to pass under water main and services with a minimum clearance of eighteen (18") inches.

#### **01015.1.04 SPECIAL REQUIREMENTS**

- A. If the public water and/or sanitary sewer lines cross telephone, telegraph, electric cables, gas, oil or water lines, no excavation or pipe laying shall be done at those crossings without prior authorization to the utility and the presence of an authorized representative from the office of the authority having jurisdiction (if required). Attention is directed to the provisions of Act No. 287 of the Commonwealth of Pennsylvania, entitled "Underground Utility Line Protection Act", and full compliance therewith is required.
- B. The CONTRACTOR should plan work so as to provide adequate protection during storms. Certain portions of the work may be affected during storms and floods. Provisions for preventing damage should be made available at all times. Public water and/or sanitary sewer piping and appurtenances, force mains, pumping stations, metering vaults, and other work shall be protected at all times against damage from uplift due to high ground water levels.
- C. All taps to existing AUTHORITY water and sanitary sewer mains shall be done by AUTHORITY personnel, or under the supervision of AUTHORITY personnel, as determined by the AUTHORITY.

- D. All AUTHORITY public water and sanitary sewer valves shall be operated by AUTHORITY personnel, or under the supervision of AUTHORITY personnel, as determined by the AUTHORITY.
- E. The CONTRACTOR will be required to maintain at all times during construction of the work of the Contract, the flow of sewage in the existing sewerage systems to which connections are being made.
- F. Connections to existing sewers and manholes shall be made in such a manner as to provide a watertight installation. The CONTRACTOR shall take all necessary precautions to prevent cutting debris from entering the existing sewage flow. Lateral connections to existing sewers shall be made using a Sealtite sewer pipe saddle, as manufactured by Geneco, or approved equal.
- G. Sewer connections to existing manholes shall be made by carefully boring an opening no greater than two (2) inches around the new pipe. The existing bench and channel must be cut to invert to form a channel for the new pipe. An "A-Lok" field sleeve, as manufactured by Atlantic Concrete Products, or approved equal, shall be installed, and the inside face of the gasket shall be filled with non-shrink hydraulic cement. The newly cut channels shall be finished with non-shrink grout and troweled to meet the existing channel.
- H. Where water and sanitary sewer facilities are to be constructed within the limits of paved streets, all removal and replacement of street paving shall be in strict conformance with the requirements of the local Municipality and/or the Pennsylvania Department of Transportation, as applicable. The CONTRACTOR shall pay the cost of inspection by the Municipality or Pennsylvania Department of Transportation personnel.
- I. The use of a "HYDRA-HAMMER" for compaction of backfill will not be permitted.
- J. The use of calcium chloride in concrete is prohibited.

#### **01015.1.05 SEWAGE FLOW BYPASS PUMPING**

- A. Bypass pumping of sewage may be required at various locations throughout the project in order to complete pipe work, connections to manholes, testing, channel work, etc. The CONTRACTOR is responsible for this bypass pumping as required by the ENGINEER.

#### **01015.1.06 CONNECTIONS BELOW THE SEWER LATERAL ELEVATION**

- A. It shall be prohibited to connect any plumbing fixture, appliance or equipment to a sanitary sewer lateral if the outlet of such facility is located below the centerline elevation of the lateral. Such facilities (herein referred to as "sublateral facilities") may only be connected to the sewer system if approved by the AUTHORITY and ENGINEER.
- B. The AUTHORITY shall not be responsible for loss of or damage to the property, nor of injury to persons, on account of sewage backup through sublateral facilities, regardless of how such facilities have been installed. AUTHORITY strongly discourages this type of installation and has adopted the following conditions in an effort to reduce the risk of a sewer backup. The AUTHORITY neither represents nor warrants that adherence to these conditions will prevent any sewage backup.

- C. The customer must apply for and receive a Sublateral Facilities Permit before installing any sublateral facility. Plans of the proposed installation must be submitted to and approved by the AUTHORITY. A plan review fee, as established from time to time, shall be charged to the customer by the AUTHORITY.
- D. Sewage grinder pump systems and other sublateral facilities shall conform in all respects to the International Plumbing code, most recent edition or the edition in effect for the governing municipality.
- E. The sublateral facilities and/or grinder system shall conform to the following technical requirements, as depicted in Standard Detail S-11, and as approved during the plan review process:
1. All piping below the building sewer lateral shall be vented as required for a gravity system.
  2. Each sublateral facility shall be equipped with a check valve and two isolation valves upstream of the connection to the building lateral. One isolation valve and the check valve shall be in close proximity to the fixture, and the second isolation valve shall be next to the point of connection to the building lateral.
  3. If more than one sublateral facility and/or grinder pump system is to be used for a single building, a single connection to the building lateral will be allowed provided that each facility/grinder pump has a check valve and isolation valve, all upstream of the junction with the discharge from the other sublateral facilities/grinder pumps. In addition, a separate isolation valve shall be installed between this junction and the building lateral.
  4. Fixtures (e.g., washing machines and toilets) to be installed below the elevation of the sewer lateral, and not draining to a grinder system sump, may be allowed provided that each such fixture has sufficient pressure to discharge above the building lateral and is equipped with an individual pump and valve(s) conforming to these conditions.
  5. Under no circumstances shall a vent for any sublateral facility be connected to the building's sanitary sewer lateral. Vent sizes for each grinder pump sump shall be determined in conjunction with pump capacity, as prescribed by the International Plumbing Code. No vent or air inlet shall be located within ten feet of any building door, window or fresh air intake.
- F. In addition to the required sublateral facility components described herein, a check valve shall be installed in the building plumbing or sewer lateral (as appropriate) immediately upstream of the connection from a pumped sublateral fixture. This is to prevent pressurized sublateral flows from being forced into gravity fixtures located above the elevation of the lateral. Where two or more sublateral fixtures connect to a lateral, a single check valve upstream of the most upstream sublateral connection will be allowed.
- G. The plumber or contractor who will install the sublateral facility or grinder system must first obtain a copy of the AUTHORITY Advisory memorandum, and all other pertinent codes and details, that describe the required methods of installation.

**PART 2 - PRODUCTS**

This Section not Used.

**PART 3 - EXECUTION**

This Section not Used.

**END OF SECTION**

**SECTION 01420**  
**PRECONSTRUCTION AUDIO-VIDEO DOCUMENTATION**

**PART 1 – GENERAL**

**01420.1.01 DESCRIPTION**

The CONTRACTOR shall furnish all labor, materials and equipment necessary for audio-video documentation, in digital format, of surface features located within the zone of influence of construction operations; specifically for construction in off-site easements and road right-of-way. For projects with extensive off-site water and/or sewer facilities, and/or within the right-of-way limits of a state highway, or when required by the ENGINEER or AUTHORITY, the CONTRACTOR shall engage the services of a professional videographer actively involved with color audio-video recordings, in digital format, for various municipalities and construction projects similar to the work included under this Project. Include adjacent private properties in the video which could be affected by the Work, but do not access private property without property owner's permission.

**01420.1.02 QUALITY ASSURANCE**

- A. The ENGINEER may make such investigation as deemed necessary to determine the ability of the CONTRACTOR or videographer to perform the work, and the CONTRACTOR shall furnish to the ENGINEER all such information and data for this purpose as the ENGINEER may request. The ENGINEER reserves the right to reject the CONTRACTOR or any videographer if the investigation fails to satisfy the ENGINEER that such CONTRACTOR or videographer is properly qualified to carry out the work specified herein. Upon rejection, the CONTRACTOR shall engage the services of another videographer, which shall undergo the review and approval process specified hereinbefore.
- B. No construction shall begin prior to the review and approval of the video disks covering the construction area. Any video coverage not acceptable to the ENGINEER shall be refilmed at CONTRACTOR's expense. All video and written records shall become the property of the AUTHORITY.

**01420.1.03 SUBMITTALS**

Two (2) complete sets of project coverage video disks shall be submitted to the ENGINEER for approval. An additional copy is required for projects with work in state highway right-of-way limits.

**01420.1.04 JOB CONDITIONS**

All video work shall be done during times of good visibility. No video shall be done during periods of visible precipitation or when more than 10% of the ground area is covered with snow, unless otherwise authorized by the ENGINEER.

## **PART 2 – PRODUCTS**

### **01420.2.01 EQUIPMENT**

#### **A. Mobile Unit:**

When conventional wheeled vehicles are used, the distance from the camera lens to the ground shall not be less than twelve feet (12') to ensure proper perspective.

In some instances, audio-video coverage will be required in areas not accessible by conventional wheeled vehicles. Such coverage shall be obtained by walking or special conveyance approved by the ENGINEER.

#### **B. Audio-Video:**

Audio-video shall be in digital format.

#### **C. Camera:**

Video output from camera(s) used must be capable of producing NTSC-525 lines/60 field/s. Resolution in the Y channel, minimum 500 TV lines at center, utilizing a bias lit beam split prism, in combination with Professional and/or Industrial charge-coupled device (CCD) camera, for optimum color imagery and minimum lag through ten (10) foot candles, with Geometric Distortion not to exceed 1.5% of Picture Height at any point in picture area.

#### **D. Lighting:**

The Contractor shall provide, if required, all lighting and power therefor, to fill in all shadow areas caused by trees, signs, and other objects.

### **01420.2.02 RECORDED INFORMATION**

#### **A. Audio:**

Each video disk shall begin with the current date, project name, and municipality and be followed by the general location; i.e., name of the street or location of "cross-country" line, viewing side and direction of progress.

#### **B. Video:**

The engineering stationing numbers shall be continuous, be accurate, correspond to the project stationing, and include the standard engineering symbols (for example 14+84). This transparent information shall appear in the lower half of the viewing screen.

Below the engineering stationing, periodic transparent alphanumeric information consisting of the name of the project, name of the area covered, direction of travel, viewing side, etc., shall appear. To preclude the possibility of tampering or editing in any manner, all video recordings shall, by electronic means display continuously and simultaneously generated transparent digital information to include the date and time of recording, as well as the corresponding engineering stationing numbers. The date information shall contain the month, day and year (for example 10/5/2018) and shall be placed directly below the time information. The time information shall consist of hours, minutes and seconds, separated by colons (for example 10:35:18). This transparent information shall appear on the extreme upper left-hand third of the screen.

## **PART 3 – EXECUTION**

### **01420.3.01 AUDIO-VIDEO COVERAGE**

- A. The entire project site shall be recorded. Zone of influence shall extend to 50 feet from each side of each pipeline to be installed.
- B. Audio-video coverage shall include all surface features located within the zone of influence of construction supported by appropriate audio description. Audio description shall be made simultaneously with video coverage. Such coverage shall include, but not be limited to, all existing driveways, sidewalks, curbs, ditches, roadways, landscaping, trees, culverts, headwalls, and retaining walls or buildings located within such zone of influence.
- C. Houses and buildings shall be identified visually by house number, when visible, in such a manner that structures of the proposed system; i.e., manholes on a sewer system, can be located by reference.
- D. The rate of speed in the general direction of travel of the conveyance used during recording shall not exceed 48 feet per minute. Panning rates and zoom-in, zoom-out rates shall be controlled sufficiently such that during playback will produce clarity of the object viewed.

### **01420.3.02 IDENTIFICATION**

- A. All video disks shall be properly identified by disk number, location and project name and municipality in a manner acceptable to the ENGINEER.
- B. A record of the contents of each disk shall be supplied by a sheet identifying each segment on the disk by location; i.e., roll number, street, or road viewing, counter number, viewing side, point starting from, traveling direction, and ending destination point.

### **01420.3.03 ADDITIONAL AUDIO-VIDEO REQUIREMENTS FOR BLASTING**

- A. Audio-video coverage shall include all surface features located within 500 feet of the blasting area and supported by appropriate audio description. Audio description shall be made simultaneously with video coverage. Building exterior coverage shall include, but not be limited to, all masonry features of the building, such as walls, foundations, chimneys, or porches. Building interior coverage shall include, but not be limited to, all outside basement walls and flooring. Recording shall be performed twice to record "before" and "after" blasting conditions. All defects and cracks shall be dimensioned and recorded in a written log.
- B. Video of a structure shall commence with a 360-degree pan of the exterior with the building address displayed. To maintain viewer orientation and video integrity, the camera shall run continuously as recording proceeds from exterior view to interior view. The videographer shall pan and zoom in and out to control sufficiently the clarity of the objects being viewed, and will not exceed a rate of more than two (2") inches per second on telephoto zoom.
- C. Visual Orientation: In order to orientate the viewer, all recorded material shall contain in the video portion, a display showing the direction of North by means of an adequate number of highly visible arrows or place cards, on or near the walls, floors and structures mentioned above.
- D. Three (3) attempts must be recorded by the videographer to complete the video project at each location and a log sheet describing the day, time, and disposition of the contact.
- E. At no time will the CONTRACTOR be allowed to use any electrical circuits within the building structure in order to protect the electrical circuits from overloading. All video recording shall be done during regular business hours, unless otherwise specified by the property owner or ENGINEER. The CONTRACTOR shall be responsible for notifying building owners and occupants and for coordinating videoing hours. The CONTRACTOR must enter and leave property in a professional and orderly workmanship-like manner.

**END OF SECTION**

## **SECTION 02110 CLEARING AND GRUBBING OF EASEMENTS**

### **PART 1 – GENERAL**

#### **02110.1.01 SUMMARY**

A. Section Includes:

1. Clearing
2. Grubbing
3. Stripping and stockpiling topsoil
4. Debris disposal

B. Definitions:

1. Clearing is defined as the removal of trees, brush, down timber, rotten wood, rubbish, any other vegetation, and objectionable material at or above original ground elevation not designated to be saved. Clearing also includes removal of fences, walls, guard posts, guard rail, signs, and other obstructions interfering with the proposed work.
2. Grubbing is defined as the removal from below the surface of the natural ground of stumps, roots and stubs, brush, organic materials and debris.

#### **02110.1.02 JOB CONDITIONS**

- A. Prior to any excavation, the CONTRACTOR shall properly prepare the site of the work. CONTRACTOR to clear all obstructions within the permanent and temporary construction easements in accordance with approved Construction Drawings.
- B. All clearing and grubbing and disposal of debris must be performed by the CONTRACTOR as a part of the Work.
- C. All personal property and utility damage caused by CONTRACTOR during the clearing and grubbing operation shall be remedied at the CONTRACTOR's expense.

### **PART 2 – PRODUCTS**

#### **02110.2.01 MATERIALS**

A. Temporary Fencing:

1. High-visibility orange, high-density polyethylene mesh, ultraviolet-stabilized with #14 gauge steel or nylon cable ties; minimum height to be 4 feet. Rigid metal or wood posts, minimum length 6 feet.

2. Undamaged picket snow fence, 4' high, formed of wooden slats, tightly woven with wire cable. Soil-set fence posts, studded "T" type, 6' high.

B. Tree Wound Dressing:

1. Antiseptic and waterproof, asphalt base.

## **PART 3 - EXECUTION**

### **02110.3.01 PREPARATION**

- A. Notify ENGINEER at least 48 hours prior to beginning any clearing work in easements.
- B. Protect benchmarks, utilities, sidewalks, fencing, lawns, existing trees, shrubs, and other landscape features designated for preservation with temporary fencing or barricades satisfactory to the Resident Project Representative. No material shall be stored or construction operation carried on within four (4) feet of any tree to be saved or within the tree protection fence. Such protection shall be maintained as long as necessary to prevent damage due to operations of the CONTRACTOR.
- C. When a private enclosure fence encroaches on the work area, notify the property owner at least five (5) days in advance of the clearing/grubbing operations to permit the property owner to remove it, construct a supplemental fence, or make such other arrangements as may be necessary for security purposes. Upon failure of the property owner to reasonably proceed with the work required to secure their property, carefully remove the fence, in whole or in part, and neatly pile the materials onto the property owner's property.
- D. Structures and obstructions such as fences, shrubs, etc., which are to be removed prior to the start of construction, must be removed, stored, and protected by the CONTRACTOR. It is the CONTRACTOR's responsibility to replace these features to an equal or better condition than when they were removed.

### **02110.3.02 UTILITY RELOCATIONS**

- A. Inform all companies, individuals and others owning or controlling facilities or structures within the limits of the work which have to be relocated, adjusted or reconstructed in sufficient time for the utility to organize and perform such work in conjunction with or in advance of CONTRACTOR operations.
- B. Comply with the provisions of Pennsylvania "One Call" Act 287, most current requirements.

### **02110.3.03 CLEARING**

- A. Confine clearing as required to within the limits of the easements, right-of-ways, and DEVELOPER's property.

- B. All individual trees, groups of trees, or bushes shall be removed from easements. All stumps and roots larger than three inches (3") in diameter shall be excavated and removed. Where stumps are not required to be grubbed, they shall be flush cut with ground elevation.
- C. In areas of fill or embankment where the depth of fill or embankment is to be 5-feet or more in depth, trees and stumps shall be cut off not more than six inches (6") above existing grade. If the fill is to be less than 5-feet, all trees, stumps, roots, brush, root mat and debris shall be removed completely.
- D. Fell trees in a manner that will avoid damage to trees, shrubs, and other installations which are to be retained.
- E. Trees requiring removal or trimming of roots and branches which interfere with construction or traffic shall not be removed without written permission of the ENGINEER, AUTHORITY, or Municipality.
- F. Transplanting of trees and pruning procedures shall conform to the latest standards of the America Association of Nurserymen.

#### **02110.3.04 GRUBBING**

- A. Grub areas within the construction limits to remove roots and other objectionable material to a minimum depth of 2 feet below the surface.
- B. Remove all stumps within the cleared areas unless otherwise authorized by the AUTHORITY or ENGINEER.
- C. All depressions made as the result of grubbing operations shall be backfilled with suitable material and compacted.

#### **02110.3.05 STRIPPING AND STOCKPILING TOPSOIL**

- A. All grass and sod shall be carefully removed from all lawns and stored separately, protected, and relaid following backfill and tamping of the excavated areas, provided it is in suitable growing condition. If the sod is not satisfactory for replanting, the CONTRACTOR shall seed the excavated area. The CONTRACTOR shall also remove all plant material, where required, store, and replant the material following completion of the work, or replace with a suitable material. The plant material shall be examined by the ENGINEER from time to time after being planted and during the maintenance bond period. All material that has died or is dying shall be replaced by the CONTRACTOR at their expense.
- B. Strip topsoil to whatever depth it may occur from areas to be excavated, filled, or graded and stockpile at a location approved by the County Conservation District, for use in finish grading.
- C. Topsoil within easements or right-of-ways shall not be used as backfill or removed from the site.

### **02110.3.06 DEBRIS DISPOSAL**

- A. Trees, logs, branches, brush, stumps, roots, and other debris resulting from clearing and grubbing operations associated with the Work on the Project site and/or within off-site easements/public right-of-ways shall become the property of CONTRACTOR and shall be disposed of in conformance with all applicable Federal, State and local regulations.
- B. Debris resulting from the clearing and grubbing work shall not be deposited or buried on the Project site, easements, or right-of-ways.
- C. Debris may NOT be burned anywhere on project site.

### **02110.3.07 RESTORATION**

- A. Repair all injuries to bark, trunk, limbs, and roots of remaining plants by properly dressing, cutting, tracing and painting, using approved arboricultural practices and materials.
- B. Replace trees, shrubs and plants designated to be saved which are permanently injured or die within one (1) year as a result of construction operations with like species acceptable to the property owner.
- C. Remove protective fences, enclosures and guards upon the completion of the project.
- D. Restore guard posts, guard rail, signs and other interferences to the condition equal to that existing before construction operations.
- E. If the CONTRACTOR removes extra material than is required on the Project, then all suitable material removed shall be replaced by the CONTRACTOR at CONTRACTOR's own expense.
- F. If the CONTRACTOR exceeds the clearing limits specified, CONTRACTOR shall, if directed, restore areas to their original condition.

**END OF SECTION**

**SECTION 02170  
STREAM CROSSINGS**

**PART 1 - GENERAL**

**02170.1.01 SUMMARY**

A. Section Includes:

1. Construction of a ductile iron pipe utility line with a concrete encasement at a stream crossing location.
2. Construction of the stream crossing in dry conditions, which includes maintaining the excavation free of water.
3. Restoration of the affected streambed and bank areas to preconstruction conditions.
4. Temporary stream crossing.

**02170.1.02 RELATED INFORMATION**

A. Related Sections:

1. Section 02220 - Excavation, Backfill, and Compaction
2. Section 02229 - Rock Excavation
3. Section 02250 – Environmental Protection
4. Section 02610 – Utility Pipe and Fittings
5. Section 03302 – Concrete Work for Utilities

B. Associated Construction Details:

1. M-2 - Concrete Easement
2. M-8 - Pipeline Stream Crossing
3. M-9 - Pipeline Stream Crossing Alternative “B”

**02170.1.03 WORK REQUIREMENTS**

A. Work includes, but is not limited to the following principal items:

1. Construction of a stream diversion structure and the dewatering, maintenance, and pumping of the area enclosed thereby for construction of the utility line in dry conditions, to the line and grade shown on the design plans for the Project.

2. When permanent construction is complete within the stream diversion structure, all temporary stream crossing materials must be removed. This includes all filtration dams, pipes, fill materials, etc. The stream bed is to be returned to its original condition and the banks are to be stabilized by sowing grass seed, or as shown on the plans.
  3. Prosecution of the Work in such a manner as to avoid depositing any material of any nature in the stream outside the stream diversion structure.
  4. Providing soil erosion and sedimentation control measures as specified in Section 02250.
  5. Complying with the stream crossing permit issued by the County Conservation District or the PA Department of Environmental Protection. It shall be the DEVELOPER's responsibility to obtain all necessary permits and approvals.
- B. Unless otherwise specified or authorized, all work or construction that forms a part of the permanent structures shall be done in areas free from water. CONTRACTOR shall construct and maintain the necessary stream diversion structure, channels, sumps, or embankments and similar temporary construction and shall furnish and operate all necessary pumps and other facilities for dewatering and maintaining the various areas of the work free from water as required by the ENGINEER. CONTRACTOR shall, at all times during construction, provide and maintain proper equipment and facilities to promptly remove and properly dispose of all water that may enter the excavation, and keep the excavation dry so as to obtain a satisfactory undisturbed subgrade. Any water pumped from the area to be dewatered which is turbid and/or carrying sediment shall be directed to sediment traps, filters or other approved methods prior to release to the stream. Furthermore, the dewatering operation shall be carried out in such a manner that the discharge does not create an erosion problem in the receiving stream or watercourse. Dewatering operations shall prevent boiling and detrimental under-seepage at the bottom of the excavation. CONTRACTOR shall, on completion of the work, remove the stream diversion structure, equipment, and temporary construction material. Objectionable debris shall be disposed of, and the work area shall be left in a neat and sightly condition to the satisfaction of the AUTHORITY and ENGINEER. Disposal of any material in the stream will not be permitted.
- C. CONTRACTOR shall be fully responsible for the design, safety and adequacy of the stream diversion structure, for the proper construction, handling, placing, maintaining, operating and removing of all items of the stream diversion structure; and for all related services. CONTRACTOR shall be responsible for the maintenance of the area within the stream diversion structure in a dewatered condition until the ENGINEER acknowledges that the work has been satisfactorily accomplished and that the stream diversion structure may be flooded and removed. Any and all damage caused by, resulting from, or attributable to the failure, flooding or overtopping of the stream diversion structure shall be repaired or replaced to the satisfaction of the ENGINEER by CONTRACTOR and at the expense of CONTRACTOR.
- D. CONTRACTOR shall design, furnish, install, maintain, and operate all necessary pumping and other equipment including electrical facilities, pipe lines, flumes, collection and sedimentation basins, drainage facilities for constructing and dewatering the various parts of the work, and for maintaining the work within the stream diversion structure free from water and as required, after any part of the work is completed, for inspection, safety, or for any reason

determined due to weather, labor strikes, power failures, or other circumstances. Adequate diesel or gasoline-powered standby pumping units shall be provided by CONTRACTOR for this purpose, including standby reserve, which shall be maintained in first-class operating condition at all times. CONTRACTOR shall pump all water from the appurtenant works and shall keep the excavation free of water while excavating, preparing the subgrade, and while placing concrete, pipe, fittings, accessories or as otherwise required for completing the work, and shall be entitled to no claim for damages or additional compensation by reason of any amount of water that may leak through, under, or around the stream diversion structure. To help minimize siltation, all water pumped or drained from the stream diversion structure area shall be pumped to a sedimentation basin before being discharged back into the stream. At no time shall water containing sediment be discharged directly into the stream. In the event that the pumps fail for any reason, CONTRACTOR shall be fully responsible for all damage resulting from such failure.

- E. CONTRACTOR shall NOT use a streambed as a roadway for moving equipment and vehicles from one side to the other. Temporary stream crossings must be constructed for such crossings as per Section 02170.1.05 of these Specifications

#### **02170.1.04 SUBMITTALS**

- A. DEVELOPER shall provide a plan for the utility and temporary crossing to the Pennsylvania Department of Environmental Protection, County Conservation District, and obtain the required permit(s).
- B. CONTRACTOR shall submit literature and/or plans showing the method of construction of the stream diversion structure that shall be submitted for approval before construction can proceed. CONTRACTOR shall at all times maintain the natural flow and water elevations of the stream and shall keep water elevations to normal levels unless weather or high seasonal conditions prevail.
- C. CONTRACTOR shall submit to ENGINEER a detailed Sequence of Construction for each stream crossing, including a soil erosion control plan, if an alternate method is proposed by the CONTRACTOR other than the recommended sequence of construction which should already have permitting approval as may be noted on the design plans. CONTRACTOR is advised that an alternative sequence of construction may require a review by the County Conservation District and/or the Pennsylvania Department of Environmental Protection prior to approval and accordingly should submit any alternative sequence of construction at least thirty (30) days before the anticipated start of construction of the stream crossing. It shall be CONTRACTOR's responsibility to obtain and pay for any permitting for alternate stream crossings other than that shown on the Drawings.

#### **2170.1.05 TEMPORARY STREAM CROSSINGS**

- A. In order for CONTRACTOR to use a streambed as a roadway for moving equipment and vehicles from one side to another, temporary stream crossings must be constructed by the CONTRACTOR prior to the start of construction on any utility stream crossing.

- B. Stone filtration dams are to be placed downstream of all stream crossings by the CONTRACTOR and as directed by the ENGINEER. The temporary stream crossing and the stone filtration dams shall be constructed as per the Drawings, at the locations indicated on the Drawings, and are to be maintained by the CONTRACTOR for the duration of the stream crossing.

## **PART 2 - PRODUCT**

### **02170.2.01 MATERIALS**

- A. The permanent materials to be incorporated in the construction shall be as follows:
1. **Gravity Sewer Stream Crossings:** Concrete encased, mechanical joint, thickness class 50 ductile iron pipe, with cement lining and asphalt coating (interior & exterior). All crossings shall provide a minimum of three (3) feet of cover over the pipe as measured from the stream bed elevation.
  2. **Pressure Pipe Stream Crossings** (sewage pump station force mains and water mains): Concrete encased, mechanical joint, thickness class 52 ductile iron pipe, with cement lining and asphalt coating (interior and exterior), Megalug® joint restraints shall be used at all stream crossing fittings as well as concrete thrust blocks.

Notes:

- a) Encasements shall be of Class C, 2,500 psi concrete and provide a minimum of 6" of concrete cover on all sides of the pipe.
- B. The temporary construction materials furnished by CONTRACTOR shall be as shown in the design plans or the shop drawings submitted by CONTRACTOR and approved by the ENGINEER.
- C. Temporary cofferdam shall be as provided by Portadam, Inc., or approved equal.

## **PART 3 - EXECUTION**

### **02170.3.01 PURPOSE**

- A. The purpose of the Recommended Sequence of Construction is to provide for construction of each stream crossing in a workmanlike and satisfactory manner while minimizing soil erosion and the resulting sediment load and turbidity downstream during and following construction activities.

### **02170.3.02 SCHEDULING**

- A. The proposed stream crossing(s) should be planned for construction during periods of relatively low stream flow conditions.

- B. Construction of the stream crossings shall be completed in one operation. Once construction activities associated with a stream crossing have commenced, the work should proceed as expeditiously as practicable to completion in order to minimize the time construction activities are occurring within the stream. The CONTRACTOR may not start another operation until the stream crossing is completed, the streambed restored, and the temporary crossing removed, unless otherwise approved by the ENGINEER.

### **02170.3.03 PROTECTION OF STREAM BANKS DURING CONSTRUCTION**

- A. Construction activities should be conducted to minimize destruction of trees and vegetation in the immediate vicinity of the stream crossing which assist in stabilizing the stream banks.

### **02170.3.04 RECOMMENDED SEQUENCE OF CONSTRUCTION**

- A. The following sequence of construction is recommended, unless Permit(s) dictate otherwise; however, CONTRACTOR may propose an alternate sequence of construction subject to prior approval by ENGINEER and the responsible Regulatory Agency.
1. Install and maintain a temporary silt fence along both sides of the stream at the stream crossing location of sufficient length and configuration to serve any tributary areas to be disturbed during the construction activities.
  2. Divert the stream flow around or through the stream crossing construction location by means of a temporary flume or pipe(s) and a sand bag diversion structure in accordance with Construction Detail M-8. An earthen diversion shall not be used. The flume or pipe(s) shall have ample capacity to convey the normal stream flow. The sandbag diversion structure should have sufficient freeboard to protect against the entry of stream water resulting from normal rainfall and must provide a sufficient area to allow for construction activities. Any stream water seepage to be removed during construction must be pumped to an onshore sedimentation pond or equivalent for removal of sediment prior to release to the stream. Pumping may be required.
  3. Excavate the proposed trench for the utility line within the sandbagged area to a point approximately ten (10) feet beyond the normal edge of stream, install the utility line as shown on the design plans, and pour the required concrete encasement in accordance with Construction Detail M-2. The pipe may be supported in the trench by the use of solid concrete block.
  4. After the concrete has cured for 24 hours, carefully backfill the trench to avoid the formation of a permanent ridge in the streambed. Rock removed from the excavation of the trench shall be used to create the new stream bed which should be at the approximate elevation prior to construction. Placement of rock shall continue to a short distance beyond the normal edge of water. After backfilling is complete, the Contractor shall remove all excess material and debris from the streambed.
  5. Remove the temporary flume or pipe(s) and the sandbag diversion structure thereby allowing the stream flow to return to the stream channel.

6. Install a temporary silt fence near the edge of the stream on both sides across the backfilled trench area which becomes a part of the temporary silt fence under Item 1.
  7. Following installation, conduct necessary grading to restore stream banks to prior condition, provide topsoil and seed all disturbed areas in the vicinity of the stream consistent with seasonal constraints. Provide erosion control matting, as required.
  8. Remove the temporary silt fences once stabilization of the trench area and stream banks has been achieved.
- B. For a crossing involving a larger stream, a temporary cofferdam system may be employed in which case the crossing procedure would occur in two (2) separate stages still incorporating all relevant steps of the above noted sequence of construction, including any required pumping.

**END OF SECTION**

**SECTION 02220  
EXCAVATION, BACKFILL AND COMPACTION**

**PART 1 - GENERAL**

**02220.1.01 SECTION DESCRIPTION**

- A. Excavation, backfill, and compaction associated with utility construction, including such related features as protection of adjacent utilities and structures, maintenance and protection of traffic, cutting paved surfaces, blasting, support of excavation, control of excavated materials, dewatering, pipe bedding, disposal of excavated materials, rough grading, and restoration.
- B. Excavation, backfill, and compaction associated with construction or installation of structures including such related features as protection of adjacent utilities and structures, blasting, support of excavation, control of excavated materials, dewatering, structure bedding, disposal of excavated material, rough grading, and restoration.

**02220.1.02 RELATED INFORMATION**

- A. Related Sections:
  - 1. Section 02110 - Clearing and Grubbing
  - 2. Section 02170 - Stream Crossing
  - 3. Section 02229 - Rock Excavation
  - 4. Section 02250 - Environmental Protection
  - 5. Section 02300 - Boring and Jacking Operations
  - 6. Section 02575 - Restoration of Paved Surfaces
  - 7. Section 02610 – Utility Pipe and Fittings
  - 8. Section 02605 – Manholes and Vaults
  - 9. Section 02905 – Landscaping
  - 10. Section 03302 - Concrete Work for Utilities
  - 11. Section 11306 - Sewage Pumping Station
- B. Associated Construction Details:
  - 1. M-1 - Standard Pipe Bedding
  - 2. M-2 - Concrete Encasement
  - 3. M-8 - Pipeline Stream Crossing
  - 4. TR-1 - Trench Restoration for Unimproved Shoulder of State Highway, Township Road, or Easement
  - 5. TR-2 - Trench Restoration for Unimproved Shoulder of State Highway or Township Road ( $\leq 3'$  from edge of pavement)

6. TR-3 - Temporary Pavement for Township Road and State Highway
7. TR-4 - Trench Restoration for Stabilized Shoulder of State Highway or Township Road
8. TR-5 - Permanent Pavement, Trench Restoration and Backfill for Township Road
9. TR-6 - Permanent Pavement, Trench Restoration and Backfill for State Highway

### **02220.1.03 QUALITY ASSURANCE**

- A. Trench excavation, backfill, and compaction testing on State Highways may be subject to inspection by representatives of PennDOT and the Work must be performed in accordance with PennDOT requirements without additional payment, even though such requirements may entail more labor services than the methods herein described.
- B. Testing Agent:
  1. Compaction testing for this Work shall be performed by and at the discretion of the ENGINEER except if required by the PennDOT Highway Occupancy Permit or Municipality's Road Opening Permit. Where compaction testing is required by permit, such compaction testing shall be performed by a soils testing agent engaged and paid for by CONTRACTOR and approved by AUTHORITY.
- C. Reference Standards:
  1. Pennsylvania Department of Transportation
    - a. Regulations Governing Occupancy of Highways by Utilities (67 PA Code, Chapter 459)
    - b. Publication 408 Specifications Pennsylvania Test Method, PTM 106, PTM 402
    - c. Publication 213, Work Zone Traffic Control
  2. American Society for Testing and Materials (ASTM):
    - a. ASTM E1557 Test Method for Laboratory Compaction Characteristics of Soil Using Modified Effort (56,000 ft-lbf/ft<sup>3</sup>)
    - b. ASTM D2922 Standard Test Method for Density of Soil and Soil-Aggregate in Place by Nuclear Methods (Shallow Depth)
- D. Compaction Testing:
  1. Conduct compaction tests at locations during backfilling operations as required by the PennDOT Highway Occupancy Permit or Township Road Opening Permit.

2. Determine compaction in state highways and shoulders by the testing procedure contained in Pennsylvania Test Method, PTM 106, Method B or PTM 402 or as noted in the PennDOT Highway Occupancy Permit.
3. Determine compaction in areas other than state highways and shoulders by the testing procedure contained in ASTM D2922 based on previously determined compaction curve data as established by ASTM D1557.

#### **02220.1.04 SUBMITTALS**

##### **A. Certificates:**

1. Submit certification attesting that the composition analysis of pipe embedment and select stone backfill materials meet specification requirements.
2. Submit certified compaction testing results from the soils testing agency for any required compaction testing.

#### **02220.1.05 JOB CONDITIONS**

##### **A. Rock Excavation:**

1. See Section 02229 relative to rock removal.

##### **B. Compaction of Backfill:**

1. Excavations shall be backfilled in layers which are individually compacted.
2. See Section 02220.3.12 for required minimum compaction densities (based on modified Proctor Curve).
3. CONTRACTOR shall maintain optimum moisture content of backfill materials to attain the required compaction density.

##### **C. Control of Traffic:**

1. Employ traffic control measures in accordance with Pennsylvania Department of Transportation Publication 213, "Work Zone Traffic Control".
2. See Section 01010.3.12 on Traffic Control.

##### **D. Protection of Existing Utilities and Structures:**

1. Take all precautions and utilize all facilities required to protect existing utilities and structures. In compliance with Act 287 of the General Assembly of Pennsylvania, advise each Utility at least three (3) working days in advance of intent to excavate, do demolition work, or use explosives, and give the location of the job site. Request cooperative steps of the Utility and suggestions for procedures to avoid damage to utility lines.

2. Advise each person in physical control of powered equipment or explosives used in excavation or demolition work of the type and location of utility lines at the job site, the Utility assistance to expect, and procedures to follow to prevent damage.
3. Immediately report to the Utility and the Resident Project Representative any break, leak, or other damage to the lines or protective coatings made or discovered during the work and immediately alert the occupants of premises of any emergency created or discovered.
4. Any utility damaged by the CONTRACTOR must be repaired by CONTRACTOR at own expense, in a manner acceptable to the Utility's representative. CONTRACTOR shall provide access to Utility's personnel at all times for purposes of maintenance, repair, and inspection.

## **PART 2 - PRODUCTS**

### **02220.2.01 PIPE BEDDING OR EMBEDMENT MATERIAL**

#### **A. PVC Pipe:**

1. AASHTO No. 8 coarse aggregate, Table C, Section 703.2, Publication 408 Specifications. Do not use slag or cinders.

#### **B. Ductile Iron Pipe:**

1. PennDOT No. 2A modified aggregate, Table C, Section 703.2, Publication 408 Specifications. Do not use slag or cinders.

#### **C. Copper Service Line:**

1. Screenings or PennDOT Fine Aggregate, Type B Bituminous Concrete Sand #3, Section 703.1, Publication 408 Specifications. Do not use slag or cinders.

### **02220.2.02 SLAB OR BASE MATERIAL**

#### **A. Concrete Slab or Precast Base:**

1. PennDOT No. 2A coarse aggregate, Table C, Section 703.2, Publication 408 Specifications.

### **02220.2.03 BACKFILL MATERIAL**

#### **A. State Highways, Shoulders, and Rights of Way**

1. From top of pipe bedding or embedment material to subgrade elevation: PennDOT select granular material (2RC), Section 703.3, Publication 408 Specifications, or in accordance with PennDOT Highway Occupancy Permit requirements.

- B. Existing Township Streets, Parking Areas, and Driveways (All Paved Surfaces):
  - 1. From top of pipe bedding or embedment material to subgrade elevation: Same as for State Highways and Shoulders or PennDOT No. 2A modified, Section 703.2, Publication 408 Specifications, subject to Township requirements.
- C. New Township Streets, Parking Areas, and Driveways (All Paved Surfaces):
  - 1. From top of pipe embedment to subgrade elevation: Excavated material may be used if free of boulders or stones larger than 6" in size, frozen lumps, debris (bricks, masonry batts, plaster, etc.), vegetation or other organic or foreign material.
- D. Unimproved Areas:
  - 1. From top of pipe embedment to subgrade elevation: Excavated material if free of boulders or stones larger than 6" in size, frozen lumps, debris (bricks, masonry batts, plaster, etc.), vegetation or other organic or foreign material.

## **PART 3 – EXECUTION**

### **02220.3.01 EXAMINATION AND PREPARATION**

- A. Identify required lines, levels, contours and datum.
- B. Notify ENGINEER of unexpected subsurface conditions and discontinue work in area until notified to resume work.
- C. Maintain and protect existing utilities identified by utility users within the Work area (See Section 02220.1.05.D).
- D. Verify that structure walls are braced to support surcharge forces imposed by backfilling operations.

### **02220.3.02 PROTECTION OF ADJACENT WORK**

- A. Underpin adjacent structures which may be damaged by excavation work, including utilities and pipe chases.
- B. Grade excavation top perimeter to prevent surface water runoff into excavation or to adjacent properties.

### **02220.3.03 MAINTENANCE AND PROTECTION OF TRAFFIC**

- A. Coordinate the work to insure the least inconvenience to traffic and maintain traffic in one or more unobstructed lanes unless closing the roadway is authorized.
- B. Maintain access to all streets and private drives.

- C. Provide and maintain signs, flashing warning lights, barricades, markers, and other protective devices as required to conform with construction operations and to keep traffic flowing with minimum restrictions.
- D. Comply with State and Local codes, permits, and regulations.

#### **02220.3.04 CUTTING PAVED SURFACES**

- A. Where installation of pipelines, structures, and appurtenances necessitate breaking a paved surface, CONTRACTOR shall make cuts in a neat uniform fashion forming straight lines both vertically and parallel with the edge of the excavation. Cut offsets at right angles to the edge of the excavation. All concrete paving must be cut with a concrete saw.
- B. Protect edges of cut pavement during excavation to prevent raveling or breaking; square edges prior to pavement replacement.

#### **02220.3.05 EXCAVATION**

- A. The CONTRACTOR shall perform all excavation of every description and of whatever substance encountered, to the depths indicated by the Drawings, as specified herein, or as required by the ENGINEER. In performing the work as specified in this section, the CONTRACTOR shall conform to the current regulations of the Pennsylvania Department of Labor OSHA regulations. All excavated materials not required for backfill shall be removed and wasted or otherwise disposed of as required or specified.
- B. Test pits may be dug by the CONTRACTOR if approved by the ENGINEER, to a depth and size as may be necessary. The CONTRACTOR may excavate for test pits, or any other miscellaneous items for the purpose of satisfying CONTRACTOR as to the location of underground obstructions or conditions, but this work shall be at the expense of the CONTRACTOR.
- C. Trenches shall be excavated, protected and backfilled as necessary for the completion of the work to be done under the contract. All excavations shall be open trenches except where and to such extent as the ENGINEER may authorize or require that the same be done by tunneling. In general, trenches may be excavated and backfilled either by machinery or by hand. The CONTRACTOR may be required to use hand excavation and backfilling where it is necessary to protect existing structures, utilities and private or public properties at CONTRACTOR's expense.
- D. If excavation is stopped on any trench for any reason and the excavation is left open for an extended length of time (as determined by the ENGINEER) in advance of construction, the CONTRACTOR shall backfill the trench and not excavate again until work proceeds.

E. Depth of Excavation:

1. Gravity Pipelines:

- a. Excavate trenches to the depth and grade shown on the profile drawings for the invert of the pipe plus that excavation necessary for placement of pipe bedding material.
- b. Excavation for laterals to shallow sewers shall provide a straight uniform grade from the main pipeline to the required elevation at the right-of-way line, plus that excavation necessary for placement of pipe bedding material.
- c. Excavation for laterals to deep sewers shall provide a straight grade at 45° from horizontal from the main pipeline to the required elevation, then continuing at a straight uniform grade to the required elevation at the right-of-way line, plus the excavation necessary for placement of pipe bedding material.

2. Pressure Pipelines:

- a. Excavate trenches to the minimum depth necessary to place required pipe bedding material and to provide a minimum four (4') feet from the top of the pipe to the finished ground elevation, except where specific depths are otherwise shown on the design plans.

3. Structures:

- a. Excavate to the minimum depth necessary to install footings, concrete slab or precast base plus that excavation necessary to place the required base material as shown on the design plans.

4. Where unsuitable bearing material including shattered rock due to drilling or blasting operations is encountered in the bottom of the excavation, continue excavation until the unsuitable material is removed, solid bearing is obtained or can be established, or concrete/concrete cradle can be placed. If no concrete/concrete cradle is to be installed, refill the excavation to required grade with pipe bedding/embedment or slab/base material as appropriate.

5. Where CONTRACTOR, by error or intent, excavates beyond the minimum required depth, backfill the excavation to the required depth with pipe bedding/embedment or slab/base material as appropriate at CONTRACTOR's expense.

F. Width of Excavation:

1. Gravity and Pressure Pipelines:

- a. Excavate trenches, including laterals, to a width necessary for placement and jointing of the pipe, and for placing and compacting pipe embedment under, around and over the pipe, but not less than 6" or more than 8" on each side of the pipe.

- b. Shape trench walls completely vertical from trench bottom to at least two (2) feet above the top of the pipe. In no case shall the trench width at the top exceed 40 inches plus the outside diameter of the pipe in all existing streets, roads, highways, paved surfaces, etc.. Trenches in rights-of-way or easements may exceed the maximum trench width if approved by the ENGINEER and provided sufficient work area is maintained and all work is performed and contained within the rights-of-way or easements at no additional cost to the AUTHORITY.
- c. For pressure pipeline fittings, excavate trenches to a width that will permit placement of concrete thrust blocks. Provide earth surfaces for thrust blocks that are perpendicular to the direction of thrust and are free of loose or soft material.

2. Structures:

- a. Excavate to the minimum distance necessary for placement/installation of the footings, concrete slab, walls or prefabricated structures and to permit proper backfill procedures to be performed.

G. Length of Open Trench:

1. Trenches shall at all times during the progress of the Work be excavated to the required width and depth for distance of at least 25 feet in advance of the end of the pipe in place. Do not advance trenching operations more than 100-feet ahead of completed pipeline provided the PennDOT Highway Occupancy Permit and/or Township road opening permit does not impose a more restrictive requirement.
2. In narrow or congested areas, when so required, the CONTRACTOR shall complete the Work up to a point designated by the ENGINEER before opening the Work ahead, in order to give access to driveways and other places. The CONTRACTOR shall in all cases arrange the Work as to cause the least inconvenience to the general public consistent with the proper prosecution of the Work

**02220.3.06 SUPPORT OF EXCAVATION**

- A. Support excavations with sheeting, shoring, and bracing or in the case of pipeline construction, a "trench box", as required to comply with, and with materials that conform to, the current Federal, State, and local laws and OSHA requirements.
- B. Install adequate excavation supports to prevent ground movement or settlement to adjacent structures, pipelines or utilities. Damage due to settlement because of failure to provide support or through negligence or fault of CONTRACTOR in any other manner, shall be repaired at CONTRACTOR's expense.
- C. All sheeting, sheet piling, braces and shores shall be driven or put in place by workers specially skilled in such work and shall be so arranged that they may be withdrawn as the trenches are backfilled, without injury to or settlement of adjacent structures and pavements.

- D. Withdraw sheeting, shoring, and bracing as backfilling proceeds unless otherwise directed by the Resident Project Representative. In withdrawing sheeting and sheet piling, special care shall be taken to ensure that all voids or holes are filled with satisfactory material and thoroughly rammed with thin rammers provided especially for that purpose.
- E. CONTRACTOR shall be solely responsible for the condition of all excavations made by CONTRACTOR. All slides and cave-ins shall be removed by the CONTRACTOR at whatever time and under whatever circumstances they may occur.
- F. The neglect, failure, or refusal of the Resident Project Representative to order the use of bracing or sheeting, or a better quality, grade, or section, or larger sizes of steel or timber, or to order sheeting, bracing, struts, or shoring to be left in place, or the giving or failure to give orders or directions as to the manner or methods of placing or driving sheetings, bracing, jacks, wales, stringers, etc., shall not in any way or to any extent relieve CONTRACTOR of any responsibility concerning the condition of excavation or of any of CONTRACTOR's obligations under the Contract, nor shall any delay, whether caused by any action or want of action on the part of CONTRACTOR, or by any act of AUTHORITY, or ENGINEER, or their agents, or employees, resulting in the keeping of an excavation open longer than would otherwise have been necessary, relieve CONTRACTOR from the necessity of properly and adequately protecting the excavation from caving or slipping, nor from any of their obligations relating to injury of persons or property.

#### **02220.3.07 CONTROL OF EXCAVATED MATERIAL**

- A. Keep the ground surface, within a minimum of 2 foot of the sides of the excavation free of excavated material.
- B. Provide temporary barricades to prevent excavated material from encroaching on private property, walks, gutters, and storm drains.
- C. Maintain accessibility to all fire hydrants, valve pit covers, valve boxes, curb boxes, fire and police call boxes, and other utility controls at all times. Keep gutters clear or provide other satisfactory facilities for street drainage. Do not obstruct natural water courses. Where necessary, provide temporary channels to allow the flow of water either along or across the site of the Work.
- D. In areas where excavations parallel or cross streams, ensure that no material slides or ashes are dumped into the stream course. Remove diversion structures and/or cofferdams immediately upon completion of construction within the stream. (See Section 02170 - Stream Crossing).

#### **02220.3.08 DEWATERING**

- A. Keep excavations dry and free of water. Dispose of precipitation and subsurface water clear of the Work in such a manner that it will not cause a public health nuisance or injure public or private property, Work completed or in progress, street surfaces, or cause interference with use of the area by the public. Where points of drainage discharge are in question, approval shall be obtained from the AUTHORITY.

- B. Maintain pipe trenches dry until pipe has been joined, inspected, and backfilled, and concrete work has been completed. The CONTRACTOR shall remove by pumping, bailing, or other means, any water which may accumulate or be found in the trenches or other excavations. CONTRACTOR shall have sufficient pumping machinery and sediment filtering devices available at all times on the site ready for immediate use. At no time is water to run through the pipes or its bedding material.
- C. Intercept and divert surface drainage away from excavations. Design surface drainage systems so that they do not cause erosion on or off the site, or cause unwanted flow of water.
- D. All Work shall comply with Federal, State, and County Conservation District requirements with respect to soil erosion and sediment control and for dewatering to any watercourse and prevention of stream degradation. (See Section 02250 – Environmental Protection).

### **02220.3.09 TUNNELING**

See Section 02300

### **02220.3.10 PIPE LAYING**

- A. Provide required pipe bedding placed in accordance with Construction Detail M-1 and these Specifications (Section 02220.2.01).
- B. Shape recesses for the joints or bell of the pipe by hand. Assure that the pipe is supported on the lower quadrant for the entire length of the barrel.
- C. Lay pipe as specified in the appropriate Section of these Specifications for pipeline construction.

### **02220.3.11 STRUCTURE PLACEMENT/INSTALLATION**

- A. Provide required base material in accordance with the design plans and Specifications (Section 02220.2.02).

### **02220.3.12 BACKFILLING EXCAVATIONS**

- A. Backfilling and tamping shall be started immediately after preliminary alignment inspection is made and shall continue without interruption to completion, unless otherwise directed by the ENGINEER.
- B. All trenches must be backfilled at the end of the day. If the CONTRACTOR does not backfill the trenches at the end of the day, all open trenches, with approval of the Township or PADOT, must be either plated (paved areas) or enclosed with approved safety fences and securely staked (non-paved areas). Blinking barricades must also be placed around the area to the satisfaction of the ENGINEER.
- C. When the trenches do not furnish sufficient material of suitable quality for refilling, the CONTRACTOR shall procure and supply the additional required material.

- D. After the backfill material has been sufficiently compacted, the CONTRACTOR shall substantially and neatly grade the entire disturbed area. All excess backfill material shall be removed by the CONTRACTOR at no additional cost to the AUTHORITY
- E. Any settlement of backfill is the complete responsibility of the CONTRACTOR and all finished grades shall be rendered permanently to the proper grades for good surface drainage, surfacing, resurfacing, repaving or laying of concrete walkways.
- F. Pipeline Trench:

After pipe installation and inspection, provide material to complete the pipe embedment in accordance with Construction Detail M-1 and these Specifications.

The following bedding or embedment requirements using the material noted in Section 02220.2.01 shall apply:

- 1. The material shall be hand placed and carefully compacted with hand-operated mechanical tampers in layers of suitable thickness to provide specified compaction around and under the haunches of the pipe. Backfill and compact the remainder of the trench with specified backfill material in accordance with Construction Details TR-1 through TR-6 and any relevant permit conditions. Employ a placement method so not to disturb or damage the utility line in the trench. Use of a Hydra-hammer or jumping-jack type compaction device is not permitted. A vibratory plate type compaction device is acceptable. Any settlement which occurs because of consolidation of the backfill during the construction period or during the maintenance period as stipulated by DEVELOPER's Agreement with AUTHORITY shall be corrected by DEVELOPER at DEVELOPER's cost.

- G. Structure Excavation:

After structure installation and inspection, backfill the excavation with specified backfill material. Employ a placement method so not to disturb or damage foundation perimeter drainage, foundation damp proofing or water proofing and protective cover or utility lines. Backfill against supported foundation walls; backfill simultaneously on each side of unsupported foundation walls. Pipelines entering the structure must be provided with the specified bedding material hand placed and carefully compacted with hand-operated mechanical tampers in layers of suitable thickness to provide specified compaction around and under the haunches of the pipe. Use of a Hydra-hammer or jumping-jack type compaction device is not permitted. A vibratory plate type compaction device is acceptable. Any settlement which occurs because of consolidation of the backfill during the construction period or during the maintenance period as stipulated by DEVELOPER's Agreement with AUTHORITY shall be corrected by DEVELOPER at DEVELOPER's cost.

- H. Lift Thickness Limitations:

- 1. Lift thicknesses shall be limited to four (4) inches for pipe embedment, eight (8) inches maximum for pipeline trenches within paved areas and twelve (12) inches maximum for pipeline trenches in non-paved areas and for structure excavations. Lift thicknesses shall also comply with requirements proposed by any PennDOT Highway Occupancy

Permit. In no case shall maximum lift thickness placed exceed the maximum limits specified by the manufacturer's recommendations for the compaction equipment to be utilized. Compaction equipment shall not be used over the pipe until sufficient backfill has been placed to insure that such equipment will not damage or disturb the pipe.

2. Lift thickness limitations specified for State highways, shoulders, or embankments govern over the compaction equipment manufacturer's recommendations.

I. Unsuitable Backfill Material:

1. Where the Resident Project Representative deems backfill material to be unsuitable and rejects all or part thereof due to conditions prevailing at the time of construction, remove the unsuitable material and replace with suitable backfill material.

**02220.3.13 COMPACTION REQUIREMENTS**

A. The following compaction densities (based on modified Proctor Curve) shall be achieved:

1. Building Foundation and Structural Slab on Grade: 95%, for the backfill material being used.
2. Exterior Side of Structure Walls: 95% to a point 5' from building wall, then 90%, for the backfill material being used.
3. Trench Backfill and Fill under Asphalt Pavement: 95% (not including base course materials), for the backfill material being used.
4. Trench Backfill within unpaved areas: 90%, for the backfill material being used.

**02220.3.14 DISPOSAL OF EXCAVATED MATERIAL**

- A. Excavated material remaining after completion of backfilling shall remain the property of CONTRACTOR, removed from the construction area, and disposed of legally.

**02220.3.15 ROUGH AND FINE GRADING**

- A. Grade areas disturbed by construction to a uniform finish. Form the bases for terraces, banks, lawns and paved areas.
- B. Grade areas to be paved to depths required for placing subbase and paving materials. Top surface of exposed subgrade to be plus or minus one inch.
- C. Grade areas to be top soiled and seeded to 4" below indicated finish contours.
- D. Slope grade away from structures at a minimum 2 inches in 10 feet unless otherwise noted on design plans.

### **02220.3.16 RESTORATION OF UNPAVED SURFACES**

- A. Restore unpaved surfaces disturbed by construction to equal the surface condition prior to construction.
- B. In all unpaved areas, the CONTRACTOR shall crown the top of all backfilled excavations. This crown is to be constructed after the trench backfilled material has been tamped.
- C. Restore grassed areas in accordance with Section 02905 - Landscaping.

### **02220.3.17 RESTORATION OF PAVED SURFACES**

- A. The CONTRACTOR shall immediately upon completion of the tamping, place and roll a two (2") inch layer of temporary hot mix paving in all roads, streets, State Highways, driveways, parking lots (all paved areas) etc.. The CONTRACTOR shall not proceed to excavate additional trench until this work is completed and approved, unless specifically directed otherwise by the ENGINEER.
- B. See Section 02575 – Paving Restoration.

**END OF SECTION**

## **SECTION 02229 ROCK REMOVAL**

### **PART 1 - GENERAL**

#### **02229.1.01 SUMMARY**

A. Section Includes:

1. Removal of rock during excavation.
2. Mechanical methods and explosive methods to assist rock removal.

#### **02229.1.02 RELATED INFORMATION**

A. Related Sections:

1. Section 01010 - General Requirements: Blasting Requirements
2. Section 02220 - Excavation, Backfill and Compaction
3. Section 02300 - Boring and Jacking Operations

#### **02229.1.03 QUALITY ASSURANCE**

A. Reference Standards:

1. National Fire Protection Association (NFPA):  
NFPA 495 - Explosive Materials Code

2. PA Department of Environmental Protection

Title 25, Chapter 210, Blaster's Licenses; Chapter 211 Storage, Handling and Use of Explosives.

- B. Seismic Monitoring Firm: Company specializing in seismic surveys with five (5) years documented experience.

- C. Explosives Firm: Company specializing in explosives for disintegration of rock, with five (5) years documented experience. All blasting shall be performed by or under the supervision of an individual with a valid Commonwealth of Pennsylvania blaster's license.

#### **02229.1.04 DEFINITIONS**

- A. Rock: Solid mineral material, with a volume in excess of ½ cubic yard or material that cannot be removed with a "Trac-Hoe" style machine with a minimum manufacturers operating weight of 41,000 pounds, a 1.5 cubic yard capacity bucket equipped with rock teeth, (without use of drilling and wedging, blasting, and/or mechanical surface impact equipment).

### **02229.1.05 REGULATORY REQUIREMENTS**

- A. The use of explosives shall comply with PA Code Title 25, Environmental Protection, Subpart D - Environmental Health and Safety, Article IV-Occupational Health and Safety, Chapter 211 Storage, Handling and Use of Explosives, NFPA 495, and Township Building Code Regulations. In the event of any conflict between the aforementioned regulations, the most stringent criteria shall apply.
- B. Obtain permit from the local Fire Marshal's Office including submission of a bond or insurance certificate before explosives are brought to site or drilling is started. Comply with all permit conditions including timely notifications to all required agencies/officials. Comply with all local requirements. Blasting will be permitted only after securing the written permission of the governing Municipality and after securing required blasting permits, insurance and bonds.
- C. Obtain approval from PennDOT relative to any predrilling within the State highway right-of-way. If blasting will be necessary within the State highway right-of-way, DEVELOPER/CONTRACTOR will submit the necessary application to PennDOT to blast along with any required insurance for public liability and property damage and/or blasting bond.
- D. Obtain a permit from the Pennsylvania Fish and Boat Commission relative to blasting in a water course or body of water.

### **02229.1.06 PROJECT CONDITIONS**

- A. DEVELOPER/CONTRACTOR shall advise owners of adjacent buildings or structures in writing, prior to performing any blasting operations to explain planned blasting operations, and pre-blast survey.
- B. Conduct a pre-blasting survey and document conditions of buildings within 500 feet of the trench or site requiring rock removal, prior to blasting, in order to assess, record and photograph existing structural conditions (interior and exterior) identifying existing irregularities. The CONTRACTOR shall perform a preconstruction audio-video and submit a copy of the videotape to the AUTHORITY prior to commencing Work.
- C. Monitor all water supply wells within 250 feet of the trench or site requiring rock removal, prior to blasting, for water level along with samples for total coliform organisms and turbidity. Monitoring and sample results from the water supply wells and structural observations of buildings shall be immediately forwarded to AUTHORITY and ENGINEER at least one week prior to the start of blasting.
- D. Store and transport all explosives in a secure and safe manner in strict conformance to all State and Township regulations; storage locations shall be clearly marked "DANGEROUS EXPLOSIVES" and shall be in care of a competent watchman at all times. In no case shall caps or other detonators be stored or transported with explosives. Explosives shall be kept on the site only in such quantities as anticipated to be required for the Project and only during the time when being used.

- E. Rock excavation within twenty (20) feet of underground utilities or structures shall be done by hand or other approval method (no blasting). If within 20 to 50 feet of underground utilities, CONTRACTOR shall perform a “Pre” and “Post” blasting video of the utility’s interior as proof of no damage (specifically to sanitary sewer). AUTHORITY reserves the right to direct that rock be removed by methods other than blasting in any cases.
- F. All exposed utilities and special structures shall be carefully protected from the effects of blast; and any damage to them by blasting shall be promptly repaired by the CONTRACTOR at CONTRACTOR’s expense, and in no case shall the blasting be done within fifty (50) feet of newly laid pipe or within 48 hours of placement of concrete within 100 feet of the blasting operation.
- G. Special care shall be exercised in areas where high tension power lines are located.
- H. Paving shall be pre-cut before blasting within roads to prevent paving from heaving beyond normal trench width. Should any street paving be damaged in consequence of the CONTRACTOR's blasting operations, CONTRACTOR shall immediately cease blasting operations and repair the damaged street paving.

**02229.1.07 PRECONSTRUCTION VIDEOTAPING REQUIREMENTS FOR BLASTING**

- A. Taped coverage shall include all surface features located within 500 feet of the blasting area and supported by appropriate audio description. Also description shall be made simultaneously with video coverage. Building exterior coverage shall include, but not be limited to, all masonry features of the building; such as walls, foundations, chimneys, or porches. Building interior coverage shall include, but not be limited to, all outside basement walls and flooring. Taping shall be performed twice to record “before” and “after” blasting conditions.
- B. Taping of a structure shall commence with a 360 degree pan of the exterior with the building address displayed. To maintain viewer orientation and taping integrity, the camera shall run continuously as taping proceeds from exterior view to inside taping. The electrographer shall pan and zoom in and out to control sufficiently the clarity of the objects being viewed, and will not exceed a rate of more than two (2”) inches per second on telephone zoom.
- C. Visual Orientation: In order to orientate the viewer, all recorded material shall contain in the video portion, a display showing the direction of North by means of an adequate number of highly visible arrows or place cards, on or near the walls, floors and structures mentioned above.
- D. Three (3) attempts must be recorded by the electrographer to complete the video project at each location and a log sheet describing the day, time, and disposition of the contact.
- E. At no time will CONTRACTOR be allowed to use any electrical circuits within the building structure in order to protect the electrical circuits from overloading. All videotaping shall be done during regular business hours, unless otherwise specified by the property owner or ENGINEER. The CONTRACTOR shall be responsible for notifying building owners and occupants and for coordinating the taping of the house. The CONTRACTOR must enter and leave property in a professional and orderly workmanship-like manner.

### **02229.1.08 SCHEDULING**

- A. Schedule Work to avoid disruption to occupied buildings nearby.

## **PART 2 - PRODUCTS**

### **02229.2.01 MATERIALS**

- A. Explosives: Type recommended by explosives firm.
- B. Delay Device: Type recommended by explosives firm.
- C. Blast Mat Materials: Type recommended by explosives firm.
- D. Mechanical Disintegration Compound: Grout mix of materials that expand on curing.

## **PART 3 - EXECUTION**

### **02229.3.01 EXAMINATION**

- A. Verify site conditions and note subsurface irregularities affecting Work of this Section.

### **02229.3.02 PREPARATION**

- A. Identify required lines, levels, contours, and datum.

### **02229.3.03 ROCK REMOVAL BY A MECHANICAL METHOD**

- A. Excavate and remove rock by the mechanical method.
- B. Drill holes and utilize expansive tools, wedges, and/or mechanical disintegration compound to fracture rock.
- C. Cut away rock at bottom of excavation to form level bearing.
- D. Remove shaled layers to provide sound and unshattered base for footings and foundations.
- E. In utility trenches, excavate to 6 inches below invert elevation of pipe and 12-16 inches wider than pipe outside diameter (minimum 6 inches on each side).
- F. Shattered or fractured rock may be allowed by AUTHORITY as trench backfill where native backfill material is permitted provided that the size requirement in Section 02220.2.03 is achieved. Otherwise, excavated rock must be removed from site.
- G. Correct unrequired rock removal in accordance with the requirements of Section 02220.

#### **02229.3.04 ROCK REMOVAL BY EXPLOSIVE METHODS**

- A. If rock is uncovered requiring the explosives method for rock disintegration, notify ENGINEER and execute as follows.
- B. The CONTRACTOR shall use the utmost care in the use of explosives necessary for the completion of the Work and not endanger life or property. The CONTRACTOR shall be solely responsible for injury to persons or property located within or beyond the area or scope of the project that may result from use of explosives.
- C. Provide seismographic monitoring during progress of blasting operations. Keep and submit to AUTHORITY upon request an accurate record of each blast which includes the general location of the blast, the depth and number of drill holes, the kind and quantity of explosive used, particle/ground velocity and displacement, decibels, and other data as required for a complete record.
- D. Drill blasting holes, prepare blasting charges and cover area with blasting mats.
- E. Prior to blasting, sufficient warning shall be given all persons in the vicinity, and traffic shall be stopped at the proper distance from the site and controlled by flagmen.
- F. Perform blasting to disintegrate rock and remove from excavation. Use such quantities and strengths of explosives and perform blasting in such manner as will break the rock approximately to the desired lines and grades, yet will leave rock not requiring excavation in an unshattered condition.
- G. Remove rock at excavation bottom to form level bearing.
- H. Remove shaled layers to provide a sound and unshattered base for footings, foundations, and utility construction.
- I. In utility trenches, excavate to 6 inches below invert elevation of pipe and 12-16 inches wider than pipe outside diameter (minimum 6 inches on each side). Rock removal should extend a minimum of 10 linear feet beyond all terminal manholes, as well as beyond the right-of-way/easement line, and beyond all laterals.
- J. Shattered or fractured rock may be allowed by AUTHORITY as trench backfill where native backfill material is permitted provided that the size requirement is in Section 02220.2.03 is achieved. Otherwise, excavated rock must be removed from site.
- K. Correct unrequired rock removal in accordance with the requirements of Section 02220.
- L. Repair any damage from blasting operations including damaged paving beyond trench width.

**02229.3.05 FIELD QUALITY CONTROL**

- A. CONTRACTOR shall provide for visual inspection by the ENGINEER, trench bottoms, foundation bearing surfaces and cavities formed by removed rock prior to further construction.

**END OF SECTION**

**SECTION 02250  
ENVIRONMENTAL PROTECTION**

**PART 1 - GENERAL**

**02250.1.01 SECTION DESCRIPTION**

- A. The Work of this section describes CONTRACTOR's responsibilities associated with erosion and sedimentation control as well as noise and dust control:
1. CONTRACTOR shall implement and maintain the Soil Erosion and Sedimentation Control Plan prepared for the Project and/or Work for the duration of the project.
  2. CONTRACTOR shall schedule and carry out the construction operations in such a manner, that soil erosion and resulting turbid stormwater runoff and sedimentation are minimized.
  3. CONTRACTOR shall use dust control applications and minimize noise levels adjacent to inhabited areas, on roadways and where directed by ENGINEER or AUTHORITY.

**02250.1.02 RELATED INFORMATION**

- A. Related Work Specified Elsewhere:
1. Section 02110 - Clearing and Grubbing
  2. Section 02170 - Stream Crossing
  3. Section 02220 - Excavation, Backfill, and Compaction
  4. Section 02229 - Rock Removal
  5. Section 02300 - Boring or Jacking Operations
  6. Section 02905 - Landscaping

**02250.1.03 QUALITY ASSURANCE**

- A. Reference Standards: The most current requirements of the following Standards shall govern.
1. Pennsylvania Department of Environmental Protection Erosion and Sediment Pollution Control Manual, March 2012 or latest Revision (PA Code Title 25, Chapters 102 and 105).
  2. County Conservation District requirements.
  3. Pennsylvania Department of Transportation Publication 408 Specifications, latest Edition.

## **02250.1.04 JOB CONDITIONS**

- A. The associated work activities include but are not limited to, the following items:
1. Temporary and permanent measures will have to be undertaken before, during and after construction to control sediment from being carried onto adjoining properties and into swales or watercourses as a result of stormwater runoff.
  2. The use of temporary control devices as shown on the Drawings and as described in these Specifications are for providing the trapping of sediment resulting from construction activities and to reduce the velocities of the temporary stormwater courses to minimize erosion.
  3. The erosion and sediment control devices shall be regularly inspected and maintained throughout the life of this project. These shall include, but are not limited to, temporary sediment basins and traps, stabilized construction entrances, perimeter dikes, perimeter swales and silt fences, as shown on the Drawings or other measures that are required for the construction of the Project and for Work.
  4. Upon completion of the Project and/or Work, and stabilization of disturbed areas, all temporary devices shall be removed by CONTRACTOR.
  5. Soil erosion and sedimentation control practices shall be consistent with the procedures outlined in the latest edition of the "Soil Erosion and Sedimentation Control Manual", Commonwealth of Pennsylvania, Department of Environmental Resources.

## **PART 2 - PRODUCTS**

### **02250.2.01 MATERIALS**

- A. Silt Fence
1. Type B, Class 3 as described in Sections 735 and 865 of PennDOT Publication 408 Specifications, latest Edition.
- B. Coarse Aggregate (Stabilized Construction Entrance)
1. AASHTO #1, Table C, Section 703.2, Publication 408 Specifications.
- C. Stabilized Fabric
1. Type A, Class 2 geotextile fabric as described in Section 735 of PennDOT Publication 408 Specifications, latest Edition.
- D. Straw Bales

- E. Temporary Seeding
  - 1. See Section 02905
- F. Permanent Seeding
  - 1. See Section 02905
- G. The jute matting for stream bank stabilization shall be of heavyweight or approved yarn type material with a plain weave mesh having a 0.5” to 1” square opening and weighing a minimum of 14 ounces per square yard.
- H. Calcium chloride shall be as described in Section 721 of PennDOT Publication 408, latest Edition.
- I. Compost Filter Sock
  - 1. In accordance with PADEP Erosion Control Manual, Table 4.1 and 4.2.

### **PART 3 - EXECUTION**

#### **02250.3.01 GENERAL PROCEDURES**

- A. The CONTRACTOR shall obtain all necessary regulatory agency permits and approvals for earthmoving activities associated with the Work, and shall strictly comply with the requirements of the agencies. The CONTRACTOR shall maintain at the work site, a copy of the Erosion and Sedimentation Control Plan and Plan Approval for the project.
- B. All work shall conform to the County Conservation District approval requirements and to the Pennsylvania Department of Environmental Protection (PADEP) regulations.
- C. At least seven days before earthmoving will begin, the CONTRACTOR, by telephone or certified mail, shall notify the County Conservation District of the date of beginning of construction and invite the local County Conservation District Representative to attend a pre-construction conference. The CONTRACTOR shall have the Erosion Control Plan available at the site of the activity at all times
- D. CONTRACTOR shall supply, install, and maintain, all temporary erosion and sediment control measures, as set forth in the Soil Erosion and Sedimentation Control Plan prepared for the Project and/or Work, for the duration of construction or until final controls become effective.
- E. CONTRACTOR shall exercise care to preserve the natural landscape and shall conduct construction operations so as to prevent any unnecessary destruction, scarring, or defacing of the natural surroundings in the vicinity of the work area. CONTRACTOR shall restore, all areas unnecessarily destroyed, scarred or defaced.

- F. Construction shall not impair surface drainage, constitute a potential erosion hazard, or act as a source of sedimentation to any adjacent property or watercourse. All construction equipment shall be operated in such a manner as to prevent pollution of any streams.
- G. All applicable regulations of fish and wildlife agencies and statutes relating to the prevention and abatement of pollution shall be complied with in the performance of CONTRACTOR's work.
- H. The erosion control measures and facilities shall be constructed under the supervision and competent inspection of an individual trained and experienced in erosion control. Control facilities shall be frequently inspected to insure effective control.
- I. All slopes, channels, ditches, or any disturbed area shall be permanently stabilized immediately after final grading or upon temporary cessation of Work. Where the activity ceases for 4-days or more, interim stabilization measures shall be implemented immediately.
- J. When the approved erosion control measures and facilities are completed, the CONTRACTOR shall notify the Department of Environmental Protection and the County Conservation District so that a final inspection of the measures and facilities may be made.
- K. CONTRACTOR shall ensure that noise levels and dust are maintained within acceptable limits when working adjacent to inhabited areas and on roadways, as described herein. Acceptable limits shall be as defined by ENGINEER, and as specified in this section.
- L. If and when it becomes necessary, the AUTHORITY will inform CONTRACTOR of unsatisfactory construction procedures and operations insofar as dust control, erosion control, noise control, and water pollution are concerned. If the unsatisfactory construction procedures and operations are not corrected promptly, AUTHORITY may suspend the performance of the construction until the unsatisfactory condition has been corrected.

### **02250.3.02 EROSION, SEDIMENT AND DUST CONTROLS**

- A. CONTRACTOR shall schedule and conduct operations to minimize erosion of soils and to prevent silting and muddying of streams, rivers, irrigation systems and impoundments (lakes, reservoirs, etc.). Construction of drainage facilities and performance of the Contract work which will contribute to the control of erosion and sedimentation shall be carried out in conjunction with earthwork operations or as soon thereafter as practicable. The area of bare soil exposed at any one time by construction operations shall be kept to a minimum.
- B. Dumping of excavated or spoil material into adjacent streams or on the banks of the stream where it may wash or slide into stream waters shall not be permitted. Dumping of excavated material, other than for stockpiling for backfilling of trenches, shall not be permitted in wetlands.
- C. Only permitted temporary stream crossings shall be used to convey equipment and materials from one stream bank to the other. Under no circumstances will construction equipment be permitted to cross natural stream channels. The crossing of a creek or water course is covered in Section 02170 of these Specifications

- D. Dewatering or pumping out of excavated areas directly into existing storm ditches or natural channels which causes silt deposition, turbidity and/or possible erosion of banks is prohibited. CONTRACTOR shall provide sedimentation basins, filter fabric sedimentation collectors or other approved methods for the filtering of water pumped from cofferdams and/or trenches at the locations designated by ENGINEER. It shall be CONTRACTOR 's responsibility to conform to the DEP “Erosion and Sediment Pollution Control Program Manual”.
- E. Prior to the suspension of construction operations, if required, CONTRACTOR shall shape the earthwork in a manner that will allow a minimum of erosion from storm runoff. Temporary erosion and sediment control measures such as berms, dikes, slope drains, or sedimentation basins deemed necessary by ENGINEER shall be provided and maintained until permanent facilities are completed and operative.
- F. CONTRACTOR shall use dust control applications when required in disturbed areas and by ENGINEER. Dust control shall be accomplished by spraying water on the surface of the disturbed ground or roadway, or by the use of calcium chloride or by other method, as approved by ENGINEER.

### **02250.3.03 EROSION AND SEDIMENT CONTROL PROCEDURES**

- A. Schedule: The general erosion and sedimentation control schedule shall be as follows:
  - 1. Install stabilized construction entrances, silt fences, sediment traps, hay bales, stone filters, and sedimentation traps or basins, as required by the Drawings.
  - 2. Excavate trench, install piping, and backfill trench.
  - 3. Excavate and install structures, and backfill.
  - 4. Restore existing grades and temporarily stabilize.
  - 5. Remove stabilized construction entrances and sedimentation traps or basins, restore disturbed areas, and permanently stabilize.
  - 6. Once all disturbed areas have been permanently stabilized, remove silt fences, hay bales, and stone filters.
- B. Erosion and sedimentation control practices including installation of silt fences shall be consistent with procedures outlined in "Erosion and Sediment Pollution Control Program Manual", Commonwealth of Pennsylvania, Department of Environmental Protection Bureau of Water Quality Protection – dated April 2012, or latest edition.
- C. Stabilized construction entrances shall be placed at all construction access points from roadways to the construction site.
  - 1. Ballast shall be replenished when choked with mud from construction traffic.

2. Install stabilization fabric underneath ballast for construction entrances with a minimum of two (2) feet of overlap.
  3. Wheel loading will not be permitted until stone is placed.
- D. Should any of the temporary or permanent erosion and sediment control measures employed by CONTRACTOR fail to produce results which comply with the requirements of the Commonwealth of Pennsylvania and local agencies, CONTRACTOR shall immediately take whatever steps are necessary to correct the deficiency at CONTRACTOR's expense.
- E. CONTRACTOR shall clean sedimentation facilities and dispose of accumulated material as specified in Section 02220 for excess material. It shall be CONTRACTOR's responsibility to ensure sedimentation facilities perform as intended and are maintained to handle required capacity. Sediment shall at no time be permitted to accumulate in sedimentation basins to a depth sufficient to limit storage capacity or interfere with the settling efficiency thereof. The sediment removed shall be handled and disposed of in a manner that will not create pollution problems and so that every reasonable and practical precaution is taken to prevent the said material from reaching the Waters of the Commonwealth.
- F. When borrow material is obtained from other than commercially operated sources, erosion of the borrow site shall be controlled both during and after completion of the work such that erosion will be minimized and sediment will not enter streams or other bodies of water. Waste or disposal areas and construction roads shall be located and constructed in a manner that will keep sediment from entering the streams.
- G. Excavated material or new backfill shall not be stored between trenches and bodies of water; rather they shall be stored on the opposite side of the trench. When work areas or gravel pits are located in or adjacent to live streams, such areas shall be separated from the main streams by a dike or other barrier to keep sediment from entering a flowing stream. Care shall be taken during the construction and removal of such barriers to minimize the muddying of a stream.
- H. All waterways shall be promptly cleared of false work, piling, debris, temporary stream crossings, stone and earth berms, or other obstructions placed during construction operations and not a part of the finished work. All removed materials shall be hauled to approved locations for disposal. No materials shall be deposited on floodplains or wetlands.
- I. Siltation control shall be provided during construction, and bank stabilization shall be undertaken by planting of grasses, shrubbery, or trees immediately after completion of each phase of the project.
- J. Pollutants such as fuels, lubricants, bitumens, raw sewage and other harmful materials shall not be discharged into or near rivers, streams, wetlands, and impoundments or into natural or manmade channels leading thereto. Wash water to waste from concrete mixing operations shall not be allowed to enter live streams or wetlands.
- K. Water from aggregate washing or other operations containing sediment shall be treated by filtration, a settling basin or other means sufficient to reduce the sediment content to not more than that of the stream into which it is discharged.

- L. Any area disturbed shall be stabilized immediately and have temporary seeding applied, in accordance with the requirements of the County Conservation District. If construction takes place during winter months when it is not practical to seed, the disturbed area shall be mulched. Temporary seeding and mulching shall be done in accordance with Section 02905.
- M. When drainage ways are crossed, they shall not be left blocked overnight if this blockage could cause siltation downstream or flooding to adjacent property. All drainage ways shall be restored to initial conditions or improved as required.
- N. Perform permanent seeding and mulching of any disturbed areas immediately following final grading of any non-paved areas within seasonal constraints. Remove all temporary erosion and sedimentation controls as soon as permanent seeding and landscaping are established. All restoration work shall proceed as the work progresses and not left until end of the project.
- O. Dust control shall be applied when required in disturbed areas, by spraying water on the surface of the disturbed ground or roadway or by other methods as approved.

#### **02250.3.04 NOISE CONTROL**

- A. CONTRACTOR shall provide adequate silencers or noise baffles on equipment so that noise levels measured at nearest property line are less than 50 dB (or less if required by Local ordinances). Additional noise baffles or silencer changeouts shall be used by CONTRACTOR to reduce equipment noise to levels that will meet this requirement. ENGINEER will use noise-measuring equipment to determine the actual decibel levels at points selected by ENGINEER. The decibel readings obtained by ENGINEER shall be accepted by CONTRACTOR. All noise abatement facilities shall be removed on completion of construction.
- B. If required by ENGINEER, CONTRACTOR shall, within twenty-four (24) hours of notice, either shut down and remove the equipment or provide adequate noise abatement. If the unsatisfactory condition persists, AUTHORITY may suspend performance of construction until the condition is corrected.

#### **02250.3.05 FIELD MODIFICATIONS**

- A. AUTHORITY reserves the right to require modifications to any or all sediment control measures provided in order to establish proper soil erosion and sedimentation control. In addition, any measures recommended or required by the County Conservation District shall be promptly implemented.

**END OF SECTION**

## **SECTION 02300 BORING AND JACKING OPERATIONS**

### **PART 1-GENERAL**

#### **02300.1.01 SUMMARY**

A. Section Includes:

1. Approach trench excavation
2. Installation of casing pipe or liner
3. Installation of carrier pipe

- B. The CONTRACTOR shall furnish all labor, materials, and equipment required to install a steel casing for the proposed State Highway or railroad crossing with a utility (sewer main, force main, or water main) as shown on the plans. The work shall include excavation and backfill, furnishing and installation of the casing pipe by specified method, carrier pipe, casing spacers, grout backfill, end seals, and restoration of all disturbed areas following the satisfactory completion of work and required testing.

#### **02300.1.02 RELATED INFORMATION**

A. Related Sections:

1. Section 02220 – Excavation, Backfill and Compaction
2. Section 02610 – Utility Pipe and Fittings
3. Section 03302 – Concrete Work for Utilities

B. Associated Construction Details:

1. M-7 - Jacking Conduit

#### **02300.1.03 QUALITY ASSURANCE**

A. Reference Standards:

1. American Society for Testing and Materials (ASTM):

A53 - Specification for Pipe, Steel, Black and Hot-dipped, Zinc-coated, Welded and Seamless

A139 - Specification for Electric-Fusion (ARC) -Welded Steel Pipe (NPS4 and Over)

A615 - Specification for Deformed and Plain Billet-Steel Bars for Concrete Reinforcement

C32 - Specification for Sewer and Manhole Brick (made from Clay or Shale) C150  
Specification for Portland Cement C270 Specification for Mortar for Unit Masonry

2. Pennsylvania Department of Transportation: Publication 408 Specifications

B. CONTRACTOR Qualifications:

1. Construction operations shall be undertaken only by a CONTRACTOR well experienced in operations of similar magnitude and conditions under transportation arteries, railroads, and surface areas which cannot be disturbed. CONTRACTOR shall demonstrate to the AUTHORITY and ENGINEER the successful completion of similar casing installations within the past five (5) years. All supervisory and operating personnel engaged in the operation of boring or drilling equipment shall be fully qualified for such work and shall have had at least twelve (12) months experience in the operation of the equipment being used.

C. Design Criteria:

1. CONTRACTOR shall be fully responsible for the design, safety and adequacy of the jacking and/or tunneling and for the proper construction, handling, placing, maintaining, operating, and removing of all equipment materials and related services.
2. Pipe and joints of leak proof construction, designed for the earth and/or other pressures present, plus highway H-20 loading or railway E-80 loading as appropriate with the associated recommended impact loading.
3. Design bracing, backstops, and use jacks of sufficient rating so that the jacking can proceed without stoppage, except for adding pipe sections and as conditions permit, to minimize the tendency of the ground material to “freeze” around the casing pipe.
4. DEVELOPER shall be responsible for all required subsurface investigations including soil borings by a licensed geotechnical company.

D. Allowable Tolerances:

1. Do not over cut excavation by more than 1” greater than the outside diameter of the casing pipe.
2. Install casing pipe with the determined vertical and horizontal alignment prior to installation of the carrier pipe.

E. Permitting:

1. The DEVELOPER shall prepare the necessary applications for permits for the construction of the crossing of the highway or the railroad. All changes by the CONTRACTOR in the methods and/or materials for the construction of the crossings must be approved by the ENGINEER and PADOT or the Railroad, prior to the start of construction of the crossing. The DEVELOPER/CONTRACTOR is responsible for obtaining all required permits at no expense to the AUTHORITY and shall be responsible to re-submit the permit application for approval if the CONTRACTOR constructs the crossing in a method other than that outlined in the application. PADOT or the Railroad must also approve all proposed changes by the

CONTRACTOR prior to the start of construction of the crossings. The CONTRACTOR shall be responsible for any and all delays in the construction progress due to this type of change.

2. The CONTRACTOR shall be responsible for becoming acquainted with such requirements as PADOT or the Railroad may demand.

#### **02300.1.04 SUBMITTALS**

- A. Submit description of proposed construction methods, including methods to establish and maintain vertical and horizontal alignment.
- B. The CONTRACTOR shall submit detailed shop drawings to the ENGINEER and to PADOT, or the Railroad, and obtain approval of methods and materials prior to commencement of work.

#### **02300.1.05 JOB CONDITIONS**

- A. Conduct operations so as not to interfere with, interrupt, damage, destroy, or endanger the integrity of surface or subsurface structures or utilities, and landscape in the immediate or adjacent areas.
- B. When boring or jacking under State highways and/or railroads, comply with applicable right-of-way occupancy permits. CONTRACTOR should note that if proposed Work involves construction operations through the property owned or controlled by PADOT or railroad, all Work shall be performed in a manner satisfactory to them, the ENGINEER or their Resident Project Representative and in accordance with the Highway Occupancy Permit or Railroad Permit.
- C. If an obstruction is encountered during the installation of the casing pipe and the obstruction is such that it prevents the forward action of the pipe, the CONTRACTOR shall cease operations and notify the ENGINEER immediately. In the event the installation cannot be continued, the casing pipe shall be abandoned in place and filled completely with grout. If the method of construction and diameter of the conduit must be changed, the CONTRACTOR shall submit a new location for the boring to the ENGINEER for review and approval. Should the CONTRACTOR elect to shift the location of the crossing, the CONTRACTOR shall make all arrangements with the jurisdictional body controlling the crossing and shall determine if any other items must be handled such as additional private or right-of-way easement, construction easement, approval of change in the application of the controlling agencies, material changes, and revisions to interconnecting piping.

### **PART 2 - PRODUCTS**

#### **02300.2.01 STEEL CASING PIPE**

- A. Steel Pipe Casing: Casing pipe shall be smooth wall manufactured from steel conforming to ASTM A-53 for Nominal Pipe Size (NPS) up to 26-inch diameter and ASTM A-36 for larger sizes, Grade B, with a minimum yield strength of 35,000 psi and minimum tensile strength of 60,000 psi.

1. Steel pipe shall have full circumference welded joints and be provided in at least 18 foot lengths, except for last section. The lengths of the casing pipe shall be joined by bevel cut full penetration butt-welds, with a smooth non-obstructing joint inside. The joints shall be welded completely around the circumference of the pipe so as to prevent water leakage from the casing throughout its length.
2. Bitumastic coating of either coal tar or asphalt base shall be applied to inside and outside of casing pipe including field welded joints (after field welding takes place); minimum 50 mil thickness.
3. The diameter and wall thickness of the steel piping shall be as listed in the following table:

<u>Carrier Pipe Size (inches)</u>	<u>Outside Diameter of Bell (inches)</u>	<u>Minimum Casing Pipe Size (inches)</u>	<u>Thickness (inches)</u>	<u>Schedule Number</u>
≤8	11.16	16	0.281	30
12	15.37	20	0.344	20
18	21.91	30	0.469	10
24	28.50	36	0.562	10
30	34.5	42	0.625	10

4. The thickness of casing shown in No. 3 are minimum thicknesses. Actual thicknesses shall be determined by the casing installer based on an evaluation of the required jacking forces. Any buckling of the casing due to jacking forces shall be repaired at no additional costs to the AUTHORITY.

- B. Casing Spacers: Spacers for installation of the carrier pipe shall be installed by the CONTRACTOR. Casing spacers shall be flanged, bolt-on style with a two-section stainless steel shell, lined with a PVC liner, minimum 0.09-inch thick, also having a hardness of 85-90 durometer. Runners shall be attached to stainless steel risers which shall be properly welded to the shell. The height of the runners and risers shall be manufactured such that the pipe does not float in the casing. Casing spacers shall be Cascade Waterworks Manufacturing Company, Advanced Products and Systems, Inc., or equal.
- C. Casing End Seals: CONTRACTOR shall construct a brick & mortar bulkhead at both ends of the casing pipe or install over the casing and carrier pipe Cascade Model CCES end seals, with stainless steel bands as manufactured by Cascade Waterworks Manufacturing Company, Advanced Products and Systems, Inc., or equal.

**02300.2.02 CARRIER PIPE**

- A. The carrier pipe shall be DIP, conforming to Section 02610 of these Specifications for the proper Class of pipe for the application as required by PADOT, Railroad, and as approved by the ENGINEER.

### **02300.2.03 BASIC MATERIALS**

- A. Concrete: PADOT Class A and Class C, per Section 03302.
- B. Brick: ASTM C32, Grade MS.
- C. Mortar: ASTM C270, Type M with water proofing admixture included.
- D. Grout: One part Portland cement (ASTM C 150) and 6 parts of sand (PennDOT Type A) mixed with water to a consistency applicable for pressure grouting.
- E. Hold Down Bar: Reinforcement Bar #3, ASTM A615, Grade 60, deformed.
- F. Sign Posts: A four (4) inch diameter post, seven (7) feet in length of galvanized steel shall be installed over the centerline of the carrier pipe on both sides of the right-of way. The post shall be installed in a hole three (3) feet deep and twelve (12) inches in diameter and the hole shall be completely filled to the ground surface with Class C concrete. Attached to each post shall be a durable, weatherproof painted metal sign that shall contain the following information:
  - a. Name and address of Owner.
  - b. Type of pipe and content.
  - c. Depth below grade at sign.
  - d. Emergency telephone number.
  - e. PADOT or Railroad file number or identification.

## **PART 3 - EXECUTION**

### **02300.3.01 GENERAL REQUIREMENTS**

- A. CONTRACTOR shall give written notice to PennDOT/Railroad with copies to the AUTHORITY and ENGINEER no less than fourteen (14) days in advance of when CONTRACTOR or CONTRACTOR's subcontractor will start work within the highway/railroad right-of-way in order that work can be properly coordinated. CONTRACTOR shall be responsible for becoming acquainted with such requirements as PennDOT/railroad may demand and should note that all work on and over the property owned and controlled by PennDOT or railroad shall conform to PennDOT/railroad rules, regulations, and requirements and be performed in a manner satisfactory to PennDOT/railroad representative. CONTRACTOR shall be responsible for traffic on the highway or railroad to be maintained at all times with safety and continuity and shall also be responsible for any damage to persons and property resulting from CONTRACTOR's operations. CONTRACTOR shall coordinate and pay for any traffic control required by PennDOT or Railroad, including flaggers employed by the Railroad.

- B. The steel casing shall be installed by means of the Boring, Drilling, Jacking, or Mining Method. All equipment and methods shall be approved by the ENGINEER or AUTHORITY and PADOT or Railroad. The boring operation shall be continued without interruption, except to install new lengths of casing pipe. The casing pipe shall be installed true to line and grade as shown on the Drawings. Installation of the steel pipe casing shall start at the low end.
- C. Sheeted and shored pits shall be constructed for boring or jacking the casing pipe. CONTRACTOR shall submit the proposed design for supporting the pit walls to the ENGINEER for review and approval. The sheeting/shoring design shall be prepared by a professional engineer, licensed to practice in the Commonwealth of Pennsylvania. If a jacking machine is used with an auger as a vehicle removing the material, the machine must be able to jack independent of the auger. The use of water or other liquids to facilitate casing placement and spoil removal is prohibited.
- D. CONTRACTOR shall provide a bulkhead and sandbags on site. CONTRACTOR shall provide a stockpile of gravel sufficient to make emergency restoration of undermined areas. CONTRACTOR shall also provide lights for night work. Lights are to be aimed into the excavation and must not be directed toward roadway or railroad traffic or buildings.
- E. Objectionable debris shall be disposed of at approved locations, and the work areas left in a neat and tidy condition.

### **02300.3.02 APPROACH TRENCH**

- A. Excavate approach trench using methods as site conditions require.
- B. Ensure pipe entrance face as near perpendicular to alignment as conditions permit.
- C. Establish a vertical entrance face at least 1 foot above top of casing.
- D. Install adequate excavation supports as specified in Section 02220.

### **02300.3.03 CASING PIPE INSTALLATION METHODS**

- A. Boring:
  - 1. Push the pipe into the ground with a boring auger rotating within the pipe to remove the spoil. Bored installations shall have a bored hole essentially the same as the outside diameter of the casing pipe. Do not advance the cutting head ahead of the casing pipe except for that distance necessary to permit the cutting teeth to cut clearance for the pipe. The machine bore and cutting head arrangement shall be removable from within the pipe. Arrange the face of the cutting head to provide a barrier to the free flow of soft material.
  - 2. If unstable soil is encountered during boring, retract the cutting head into the casing to permit a balance between the pushing pressure and the ratio of pipe advancement to quantity of soil.

3. If voids should develop greater than the outside diameter of the pipe by approximately one inch, grout to fill voids. Grouting to fill voids will be at the expense of the CONTRACTOR.

B. Jacking:

1. Construct adequate thrust wall normal to the proposed line of thrust.
2. Impart thrust load to the pipe through a suitable thrust ring that is sufficiently rigid to ensure distribution of the thrust load on the pipe.

C. Drilling and Jacking:

1. Use an oil field type rock roller bit or plate bit made up of individual roller cutter units solidly welded to the pipe which is turned and pushed for its entire length by the drilling machine to give the bit the necessary cutting action.
2. Inject a high density slurry (oil field drilling mud) to the head as a cutter lubricant. Inject slurry at the rear of the cutter units to prevent jetting action ahead of the pipe.

**02300.3.04 DEWATERING**

- A. Intercept and divert surface drainage precipitation and groundwater away from excavation through the use of dikes, curb walls, ditches, pipes, sumps or other means.
- B. Develop a substantially dry subgrade for the prosecution of a subsequent operation.
- C. Comply with Federal and State requirements for dewatering to any watercourse, prevention of stream degradation, and erosion and sediment control.

**02300.3.05 PRESSURE GROUTING**

- A. The void space between the casing pipe and surrounding earth shall be pressure grouted through the tapped fittings in the casing pipe.

**02300.3.06 CARRIER PIPE INSTALLATION**

- A. All provisions regarding cleaning, inspection, and handling, specified under pipe material sections, apply to this Work.
- B. Place the carrier pipe within the casing pipe as shown on the design plans for the project. Exercise care to prevent damage to pipe joint when carrier pipe is placed in casing. Install spacers on the carrier pipe and arrange in accordance with the manufacturer's recommended instructions to maintain the proper horizontal and vertical alignment of the carrier pipe inside the casing.
- C. All carrier pipe shall be properly insulated to prevent electrolytic or galvanic corrosion through contact with other metals.

- D. The annular space between the carrier pipe and casing shall be filled with "cement grout" as indicated on Standard Detail M-7.
- E. Pipe shall be inspected by Resident Project Representative and be tested in accordance with the applicable items in Section 02650.
- D. Close ends of casing with brick masonry construction or end seals only after the inspection and testing results are satisfactory to the Resident Project Representative.

**END OF SECTION**

## **SECTION 02519 TRACER WIRE**

### **PART 1 - GENERAL**

#### **02519.1.01 DESCRIPTION**

Install electrically continuous tracer wire with access points as described herein to be used for locating pipe with an electronic pipe locator after installation. Tracer wire shall be installed on all water mains and services (services in the right-of-way), and all pressure sewer force mains and services (services in the right-of-way).

#### **02519.1.02 SUBMITTALS**

Submit shop drawings and manufacturer's literature for approval in accordance with Section 01010.

### **PART 2 - PRODUCTS**

#### **02519.2.01 TRACER WIRE MATERIAL**

- A. Tracer wire to be twelve (12) gauge minimum High-Strength copper-clad steel (HS-CCS), insulated with a 30 mil, high-density, high molecular weight polyethylene (HDPE) insulation, and rated for direct burial use at 30 volts. HS-CCS conductor must have a 21% conductivity for locating purposes and a minimum break load of 250 lbs. HDPE insulation shall be RoHS compliant and utilize virgin grade material. Tracer wire shall be SuperFlex HS-CSS as manufactured by Copperhead Industries, LLC, or approved equal.
- B. Wire connectors to be 3M DBR, or approved equal, and shall be watertight to provide electrical continuity.
- C. Tracer wire color shall be blue for all water construction and green for all wastewater construction.

### **PART 3 - EXECUTION**

#### **02519.3.01 GENERAL**

- A. Tracer wire shall be installed on all water mains, force mains and services. The wire shall be installed in such a manner as to be able to properly tracer all mains without loss or deterioration of signal or without the transmitted signal migrating off the tracer wire.

- B. Tracer wire shall be installed in the same trench and inside bored holes and casing with pipe during pipe installation. It shall be laid in the trench below the pipe and pipe bedding being installed to ensure that the wire is not damaged during future repair operations. The tracer wire shall be securely bonded together at all wire joints with an approved watertight connector to provide electrical continuity, and it shall be accessible at all tracer wire access points.
- C. Tracer wire access points shall be at every proposed valve box collar (or manhole where required). Concentrations of multiple proposed valves near pipe intersections, i.e. tees or crosses, may require more than one access point assembly in each valve box collar.
- D. At each valve location, (including fire hydrant isolation valves), a loop of wire is to be brought up the outside of the valve box and looped inside the box through a hole drilled two (2) inch below the bottom of the lid.
- E. At the point of connection between cast or ductile iron mains, with any non-iron main, the tracer wire shall be properly connected to the iron pipe with a cad weld or approved equivalent. Tracer wire welds shall be completely sealed with the use of an approved mastic type sealer specifically manufactured for underground use. Mastic shall be applied in a thick coat a minimum of 2 inches thick and shall be protected from contamination by the backfill material with the use of a plastic membrane.
- F. Tracer wire shall be laid flat and securely affixed to the pipe at 10 foot intervals. The wire shall be protected from damage during the execution of the work. No breaks or cuts in the tracer wire or tracer wire insulation shall be permitted.
- G. Except for approved spliced-in connections, tracer wire shall be continuous and without splices from each tracer wire access point. Where any approved spliced in connections occur, 3M DBR water tight connectors, or approved equal, shall be used to provide electrical continuity.
- H. At all main end caps, a minimum of 6 feet of tracer wire shall be extended beyond the end of the pipe, coiled and secured for future connections. The end of the tracer wire shall be spliced to the wire of a six pound zinc anode and is to be buried at the same elevations as the water or force main.
- I. Spliced connections between the main line tracer wire and branch connection tracer wire shall only be allowed at water main tees, crosses or water services. The branch connection tracer wire shall be a single tracer wire properly spliced to the main line tracer wire.

### **02519.3.02 TESTING**

CONTRACTOR shall perform a continuity test on all tracer wire in the presence of the ENGINEER or the ENGINEER's representative. If the tracer wire is found to be not continuous after testing, CONTRACTOR shall repair or replace the failed segment of the wire at CONTRACTOR's own expense.

**END OF SECTION**

**SECTION 02575**  
**RESTORATION OF PAVED SURFACES**

**PART 1 – GENERAL**

**02575.1.01 SUMMARY**

- A. Section Includes:
1. Temporary Paving
  2. Permanent Paving
  3. Shoulder Restoration
  4. Curb, Gutter, Driveway Apron and Sidewalk Restoration
- B. The Construction Details note the specific paving requirements.
- C. The CONTRACTOR shall furnish all labor, materials, and equipment required to restore all paving removed or damaged by construction operations and place new paving as required.
- D. Repaving of Township/Borough roads shall be done in accordance with regulations and requirements of Township/Borough responsible for providing the Road Opening Permit. Repaving of state roads shall be done in strict accordance with regulations and requirements of the Pennsylvania Department of Transportation (PennDOT).
- E. All openings or holes cut through any paving for test holes, borings, well points, etc. shall be replaced in accordance with these Specifications and any special conditions of the Municipality's Road Opening or PennDOT Highway Occupancy permit, at the CONTRACTOR's expense.

**02575.1.02 RELATED INFORMATION**

- A. Related Sections:
1. Section 01010 - General Requirements: Traffic Control
  2. Section 02220 - Excavation, Backfill, and Compaction
  3. Section 03302 - Concrete Work for Utilities
- B. Associated Construction Details:
1. TR-3 - Temporary Pavement for Township Road and State Highway
  2. TR-4 - Trench Restoration for Stabilized Shoulder of State Highway or Township Road
  3. TR-5 - Permanent Pavement and Trench Restoration for Township Road
  4. TR-6 - Permanent Pavement, Trench Restoration and Backfill for State Highway

### **02575.1.03 QUALITY ASSURANCE**

#### **A. Referenced Standards:**

1. Pennsylvania Department of Transportation:
  - a. Regulations Governing Occupancy of Highways by Utilities (67 PA Code, Chapter 459)
  - b. Publication 408 Specifications, Latest Edition
  - c. Publication 27 - Specification for Bituminous Mixtures (Bulletin 27)
  - d. Publication 37 - Specification for Bituminous Materials (Bulletin 25)
  - e. Publication 72M - Roadway Construction Standards
  - f. Publication 213 - Work Zone Traffic Control

B. CONTRACTOR shall be experienced in paving and use the proper equipment as required by PennDOT.

C. All construction and materials shall conform to PennDOT Publication 408, latest revision. All structures and facilities shall conform to PennDOT Publication 72M, latest revision.

D. Qualifications of Asphalt Concrete Producer - Use only materials which are furnished by a bulk bituminous concrete producer regularly engaged in production of warm-mix, warm-laid bituminous concrete and is listed in PennDOT Bulletin 41, List of Commercial Producers of Bituminous Mixtures.

### **02575.1.04 SUBMITTALS**

#### **A. Certificates:**

1. Submit materials certification from bituminous and aggregate suppliers attesting that each material item complies with, or exceeds the specification requirement.
2. Submit quarry slips for each load of coarse aggregate and batch tickets for each load of bituminous concrete delivered to the project site.

### **02575.1.05 JOB CONDITIONS**

#### **A. Control of Traffic:**

1. Take measures to control traffic during repaving operations. Do not allow traffic on repaved areas until authorized by the Resident Project Representative.

2. Employ traffic control measures in accordance with the requirements of Section 01010.3.12 of these Specifications, PennDOT Publication 213, and pertinent permits by PennDOT and/or the Municipality.

B. Weather Limitations:

1. Do not place bituminous paving mixtures when surfaces are wet or when the air and surface temperature is 4°C (40°F) or lower.
2. Aggregate subbase course may be placed when air temperature is above 30°F and rising.

C. Grade Control:

1. Establish and maintain required lines and grades, including crown and slope, for each course during construction.

D. All paving damaged by the CONTRACTOR's operations beyond the limits of work shall be restored to its original condition at the expense of the CONTRACTOR.

E. All removal, protection and replacement of street, roadway, shoulder pavement, and overlay paving on State, County, or local highways and roads will be subject to inspection by PennDOT, local County, or Township/Borough representatives. Any inspection, insurance, or other charges demanded by these agencies, or other authority having jurisdiction, will be paid for by the CONTRACTOR.

## **PART 2 - PRODUCTS**

### **02575.2.01 CEMENT CONCRETE**

A. See Section 03302.

### **02575.2.02 BITUMINOUS PAVING MATERIALS AND AGGREGATES**

A. Refer to PennDOT Publication 408 Specifications. All bituminous materials and aggregates used in paving and resurfacing are designated and shall conform to the applicable portions of the State Specifications

1. Subgrade - Section 210
2. Stone Subbase - 2A coarse aggregate - Section 350, 703.2
3. Superpave Asphalt Mixture Design, WMA Base Course - Section 311, 411
4. Superpave Asphalt Mixture Design, WMA Binder Course - Section 411
5. Superpave Asphalt Mixture Design, WMA Wearing Course - Section 411
6. Bituminous Tack Coat – Section 460

7. Bituminous Seal Coat – Section 470
8. Polymer Modified Asphalt Joint and Crack Sealing - Section 469
9. Coarse Aggregate: PennDOT No. 2RC (State Highways) or 2A (Sections 350 and 703 of Publication 408)
10. Bituminous Paint Coat – Section 461

## **PART 3 – EXECUTION**

### **02575.3.01 PREPARATION OF SUBBASE FOR ROADWAY RESTORATION**

- A. All existing paving materials required to be removed in conjunction with roadway reconstruction shall be disposed of by the CONTRACTOR at CONTRACTOR's own expense. Disposal of material must comply with all local, state, and federal laws, rules, regulations, and ordinances.
- B. After removal of existing paving materials, CONTRACTOR shall backfill and compact with 2A coarse aggregate to bring the subbase to the pre-existing line and grade parallel to the finished surface, and ready to accept the paving courses. Prepare subgrade in accordance with Section 210 of PennDOT Publication 408. Compaction shall be in accordance with Section 350 of PennDOT Publication 408.
- C. For unpaved streets, provide Type 2A Material for the full width of the existing road. Aggregate surface course shall be minimum six inches (6") thick after compaction.

### **02575.3.02 PREPARATION OF EXISTING PAVEMENT**

- A. Prepare existing pavement in accordance with Section 409 of PennDOT Publication 408.
- B. Remove and dispose of loose and foreign material and excess joint sealer and crack filler from the surface of the existing pavement or previously placed courses. If necessary, use a broom.
- C. Paint existing vertical surfaces of curbs, structures, gutters, and pavements that will be in contact with bituminous mixtures with a uniform coating of bituminous bonding material. Class E-6 (AASHTO SS-1 or CSS-1), E-8 (AASHTO SS-1h or CSS-1h), Class AET shall be applied in two or more applications, or of the class and type designated for the bituminous course in accordance with Section 460 of PennDOT Publication 408.

### **02575.3.03 TEMPORARY PAVING**

- A. Temporary paving material shall be in accordance with Section 02575.2.02.A.4. Provide temporary paving immediately upon completion of trench backfilling
- B. Complete trench backfill with coarse aggregate in accordance with Construction Detail TR-3.
- C. Place temporary paving material. Compact to the required minimum thickness of 2 inches with trench roller (5 ton).

- D. Continuously maintain temporary paving at CONTRACTOR's cost to the satisfaction of the Resident Project Representative, PennDOT, and Township/Borough Road Department. Temporary paving must remain in place for a minimum of ninety (90) days, unless otherwise directed by the PennDOT Highway Occupancy Permit or Township road opening permit.

#### **2575.3.04 PERMANENT PAVING**

- A. Trim existing paving with minimum one (1) foot cutbacks to remove damaged areas. Cut straight joint lines and right angle offsets. If the pavement edges are not maintained to the satisfaction of the ENGINEER, the pavement shall be recut and the extra width of pavement removed and repaved at the CONTRACTOR's expense.
- B. Remove temporary paving material. Construct each permanent base course and surface course to the required compacted thicknesses shown on Construction Details TR-5 and TR-6 and in accordance with Publication 408 Specifications.
  - 1. Construct wearing course to match existing road profile.
  - 2. Compact each course individually using a trench roller (minimum 5 ton) for the base course and binder course and a roller (10 ton) for the wearing course.
  - 3. In the case of a Township road, if it is of "tar and chip" construction, the paving restoration shall involve 5" bituminous concrete base course and 1½" wearing course within the cut back area with a "tar and chip" application over the entire width of the Township road. This is only applicable if the Township desires this type.
  - 4. Where an overlay is required, the top surface of the binder course shall be flush with the surface of the existing pavement
- C. Where proposed asphalt paving adjoins existing asphalt paving, seal the joint with hot bituminous material in accordance with Publication 408 Specifications.
- D. Should the CONTRACTOR be required by the PennDOT permit, Municipal Road Opening Permit, or opt to or be required to place permanent pavement before the 90-day waiting period has elapsed, the permanent pavement replacement shall consist of H.E.S. reinforced cement concrete and bituminous courses.
- E. Where existing pavement is reinforced cement concrete, or reinforced cement concrete base with bituminous wearing course, the restoration for the cement concrete course shall consist of reinforced high early strength (HES) cement concrete pavement. The materials and methods used to construct the reinforced cement concrete pavement shall conform to the applicable requirements specified in PennDOT Form 408 Section 501 for Reinforced or Plain Cement Concrete Pavements. Reinforcing steel and expansion tie bolts shall be placed in accordance with the requirements.
- F. Replace pavement markings, which were covered or destroyed, in their former location.

- G. Maintain permanent paving to the satisfaction of the Resident Project Representative, PennDOT, and the Township/Borough road department throughout the required maintenance period.

### **02575.3.05 PLACING BITUMINOUS CONCRETE - GENERAL**

- A. Place bituminous concrete mixture on prepared surface, spread, and strike-off. Do not place mixtures that are below the minimum laying temperature in accordance with Section 409 of PennDOT Publication 408. Place inaccessible and small areas by hand. Place each course to required grade, cross-section, and compacted thickness.
- B. Install and adjust utility structures in correct position and elevation in conformance with PennDOT Publication 408, Section 606.
- C. Paver Placing - Spread and strike off the mixture for the entire lane width or as much lane width as practical. After the first strip has been placed and rolled, place succeeding strips and extend rolling to overlap previous strips. Complete bottom course for a section before placing top course.
- D. Hand Placing - Spread, tamp, and finish mixture using hand tools in areas where machine spreading is not possible, as acceptable to the ENGINEER. Place mixture at a rate that will ensure handling and compaction before mixture becomes cooler than acceptable working temperature.
- E. Make joints between successive work days to ensure continuous bond between adjoining work. Construct joints to have same texture, density, and smoothness as other sections of bituminous concrete course. Clean contact surfaces and apply tack coat.

### **02575.3.06 COMPACTING BITUMINOUS CONCRETE - GENERAL**

- A. Begin rolling when mixture will bear roller weight without excessive displacement. Compact the mixture with hot hand tampers or vibrating plate compactors in areas inaccessible to rollers.
- B. Breakdown Rolling - Accomplish breakdown or initial rolling immediately following rolling of joints and outside edge. Check crown, grade, and smoothness after breakdown rolling, and repair displaced areas by loosening and filling, if required, with hot material.
- C. Second Rolling - Follow breakdown rolling as soon as possible, while mixture is hot. Continue second rolling until mixture has been thoroughly compacted.
- D. Finish Rolling - Perform finish rolling while mixture is still warm enough for removal of roller marks. Continue rolling until all roller marks are eliminated and the course has attained maximum density.
- E. Patching - Remove to full depth and replace paving areas mixed with foreign materials, and defective areas. Saw cut out such areas and fill with fresh, warm bituminous concrete. Compact by rolling to the maximum surface density and smoothness.

### **02575.3.07 PROTECTION**

- A. After final rolling, do not permit vehicular traffic on pavement until it has cooled and hardened.
- B. Erect barricades to protect paving from traffic until mixture has cooled and attained its maximum degree of hardness.

### **02575.3.08 BITUMINOUS OVERLAY**

- A. Where indicated on the design plans, or directed by PennDOT, or the Resident Project Representative, place a bituminous overlay.
- B. Construct in accordance with Publication 408 Specifications. Provide paving notches to ensure smooth transition between new and existing pavement.
- C. Replace pavement markings, which were covered or destroyed, in their former location.

### **02575.3.09 HOT THERMOPLASTIC PAVEMENT MARKINGS**

- A. Provide all labor, material, and equipment necessary to replace existing pavement markings with hot thermoplastic pavement markings of the same type, width, and color to match existing, following pavement restoration.
- B. CONTRACTOR shall be experienced in the application of hot thermoplastic pavement markings as required by the Pennsylvania Department of Transportation
- C. All materials shall conform to the requirements of PennDOT Publication 408, Section 960.2. Materials shall be provided from a source listed in PennDOT Bulletin 15.
- D. Install pavement markings in accordance with the provisions of PennDOT Publication 408, Section 960.3.

### **02575.3.10 SHOULDER RESTORATION**

Restore shoulders in accordance with Construction Detail TR-4.

### **02575.3.11 DRIVEWAYS/PARKING LOTS**

- A. Trim concrete and bituminous driveway surfaces to remove damaged areas. Saw cut straight joint lines parallel to the centerline of the trench. Cut offsets at right angles to the trench centerline.
- B. Restore damaged concrete driveways with Class A concrete conforming to the requirements specified in PennDOT Publication 408, Section 704. The replaced driveway shall be of the same thickness, workmanship, and surface finish as the original driveway unless otherwise required by the ENGINEER. A minimum 6" layer of concrete reinforced with 6 x 6, W2.9 x W2.9 wire mesh will be required.

- C. Restore damaged bituminous driveways in kind or with minimum 6" layer of 2A aggregate, 4" bituminous concrete base course (for commercial parking lots and driveways) or 2" bituminous concrete base course (for residential driveways), and 1½" layer of 9.5 mm wearing course, whichever is greater. The top of this surface course shall be flush with the surface of the adjacent existing paving.
- D. Restore earth driveways with a 6" layer of 2A stone backfill.
- E. Restore stone or gravel driveways in kind.
- F. Restore brick driveways with like bricks placed on a 4" thick wet sand bed. Place bricks in like pattern and spacing.

#### **02575.3.12 CONCRETE CURB, GUTTER AND SIDEWALK REPAIRS**

- A. Replace curbing, gutter, and sidewalks damaged or removed during construction in kind to match existing or as shown on the Drawings. All joints between existing curb, gutter, and sidewalk and replacement work shall be saw cut at right angles and neatly trimmed.
- B. Reconstruct curbs, gutters, and sidewalks to the first expansion joint on either side of the damaged portion. Provide 1/4", full-depth, premolded expansion joint material between old and new joints.
- C. Reconstruct sidewalks to 4" thickness of concrete placed on a 4" base of compacted 2A coarse aggregate.

#### **02575.3.13 STORMWATER INLETS AND PIPING**

- A. Repair or replace stormwater inlets and piping damaged by construction to match existing inlets.
- B. The Resident Project Representative will determine whether the frame and grate assembly of each affected storm water inlet is suitable for reuse once it has been removed by CONTRACTOR. If the ENGINEER directs the CONTRACTOR to use these frames and grates to construct the new inlets, prior to their installation, they shall be thoroughly cleaned by wire brushing and painting with one coat of an approved asphalt base paint.
- C. Construct or repair storm water inlets and piping in accordance with relevant section of Publication 408 Specifications.

#### **02575.3.14 TESTING**

- A. Obtain a minimum of one 6" diameter core sample for each 1,000 linear feet of permanent paving, or fraction thereof, for test of depth of bituminous material courses.
- B. Take core samples at locations as directed by the ENGINEER after final compaction rolling.

- C. Bituminous or concrete courses deficient more than 1/4-inch from the specified depth in any one sample, or uniformly more than 1/8-inch in three or more samples, shall be removed and replaced to the correct depth at CONTRACTOR's expense.
- D. Refill and compact test holes with material acceptable to, and under direction of the Resident Project Representative.

**02575.3.15 MAINTENANCE**

- A. CONTRACTOR will be required to maintain, without additional compensation, all permanent and replacement of street, roadway, and shoulder pavement; all restoration of unpaved streets; all restoration of crushed stone and paved driveways; all replacement of sidewalks, curbs, and gutters; and all overlay paving of streets done by CONTRACTOR under this Work for a period of twenty-four (24) months after the date of the AUTHORITY's approval of the completion certificate issued by the ENGINEER, including the repair or removal and replacement of such work which has failed or has been damaged or wherever surface depressions have developed. Materials and methods used to repair or replace such work shall conform to PennDOT Publication 408 and these Specifications.
- B. CONTRACTOR shall be responsible for any injury or damage resulting from lack of required maintenance during the prescribed maintenance period and the AUTHORITY and ENGINEER shall be indemnified and saved harmless from any and all loss by reason of any suit or action at law based upon any occurrence or omission occurring during this period.

**END OF SECTION**

**SECTION 02605  
MANHOLES AND VAULTS**

**PART 1 - GENERAL**

**02605.1.01 SUMMARY**

A. Section Includes:

1. Precast Concrete Manholes and Vaults
2. Concrete Manhole Bases
3. Manhole Steps
4. Manhole Covers and Frames
5. Manhole inflow prevention inserts

B. The CONTRACTOR shall furnish and install precast reinforced concrete manholes and vaults as indicated on the Drawings. All precast structures shall be of the same manufacturer and shall be subject to the ENGINEER's approval.

**02605.1.02 RELATED INFORMATION**

A. Related Work Specified Elsewhere:

1. Section 02220 - Excavation, Backfill & Compaction
2. Section 02229 - Rock Removal
3. Section 02250 - Environmental Protection
4. Section 02575 - Restoration of Paved Surfaces
5. Section 02610 - Utility Piping and Fittings
6. Section 02650 – Water and Sanitary Sewer System Testing
7. Section 02905 - Landscaping
8. Section 03302 - Concrete Work for Utilities

B. Associated Construction Details

1. S-1- Standard Manhole - Type “A”
2. S-2 - Standard Manhole - Type “B”
3. S-3 - Doghouse Manhole Construction
4. S-4 - Drop Manhole Connection
5. S-5 - Standard Manhole Frame and Cover
6. S-6 - Watertight Manhole Frame and Cover
7. S-7 and S-8 Manhole Steps

**02605.1.03 QUALITY ASSURANCE**

A. Reference Standards

1. American Association of State Highway and Transportation Officials (AASHTO):  
Standard Specifications for Highway Bridges

2. American Society for Testing and Materials (ASTM):
  - A48 - Specification for Gray Iron Castings
  - C270 - Specification for Mortar for Unit Masonry
  - C478 - Specification for Precast Reinforced Concrete Manhole Sections
  - C890 - Standard Practice for Minimum Structural Design Loading for Monolithic or Sectional Precast Concrete Water and Wastewater Structures
  - C913 - Specification for Precast Concrete Water and Wastewater Structures
  - C923 - Specification for Resilient Connections between Reinforced Concrete Manhole Structures and Pipes
  - C990 - Standard Specification for Joints for Concrete Pipe, Manholes, and Precast Box Sections Using Preformed Flexible Joint Sealants
3. Federal Specification:
  - SS-S-00210 Joint Sealant Compound
4. Pennsylvania Department of Transportation:
  - Publication 408 Specifications

B. Acceptable Manufacturer:

1. All manhole and vault structures, appurtenances, and frame and covers shall be provided by a firm regularly engaged in the manufacture of such products of the types, materials and sizes required, whose products have been in satisfactory use in similar service for not less than five (5) years.
2. Manhole and vault structures shall be provided by one of the following manufacturers or approved equal:
  - a. Atlantic Concrete Products, Inc.
  - b. Monarch Precast Concrete Corporation
  - c. Terre Hill Precast Concrete,
  - d. Modern Concrete Septic Tank Company
3. Frames and covers shall be provided by one of the following manufacturers or approved equal:
  - a. East Jordan Iron Works, Inc.
  - b. Neenah Foundry Company

## **02605.1.04 SUBMITTALS**

### **A. Shop Drawings:**

1. Submit certified dimensional shop drawings of the following items:
  - Manhole sections and precast bases
  - Manhole frames and covers
  - Manhole steps

### **B. Manufacturer's Literature:**

1. Submit manufacturer's descriptive literature for the following items:
  - Pipe to manhole flexible connections
  - Water stops and wall sleeves/wall seals
  - Gasket material used to seal manhole sections
  - Specified coating
  - Stormwater protection insert
  - Chimney seal
  - Reinforcing steel
  - Joint design
  - Concrete mix design/loading calculations

- C. Submit a Statement of Compliance together with supporting data from the materials supplier attesting that the materials meet or exceed specification requirements.

## **PART 2 - PRODUCTS**

### **02605.2.01 BASIC MATERIALS**

#### **A. Coarse Aggregate Subbase:**

1. AASHTO No. 57 in accordance with Table C, Section 703.2, Publication 408 Specifications.

#### **B. Masonry Mortar: ASTM C270, Type S**

#### **C. Concrete: See Section 03302 Concrete Work for Utilities**

## **02605.2.02 MANHOLES AND VAULTS**

- A. Provide precast concrete manholes as required by Standard Details S-1 and S-2. Manholes shall consist of a base, riser sections, and cone section manufactured in accordance with ASTM C478. The cone section shall be an eccentric type with a minimum 24" access opening. Unless otherwise approved by the ENGINEER, the manhole base section shall be provided with precast flow channels sloped to provide a 2" drop across the manhole. The shelf shall slope to the channel at 1" per foot and at the channel be equal to three quarter (3/4) of the diameter of the largest pipe passing through the manhole.
- B. Provide precast concrete drop manholes as required by Standard Detail S-4. Precast concrete integral drop base and precast concrete U-shaped collars shall be as manufactured by Atlantic Products of Tulleytown, PA, or approved equal.
- C. Provide watertight precast concrete vaults as indicated on the Drawings. Vaults shall be manufactured in accordance with ASTM C913 and designed for AASHTO HS-20 live loading and installation conditions in accordance with ASTM C890. Honeycombed or retempered concrete will not be acceptable.
- D. Manholes for interceptors and trunk sewers, and manholes receiving a pump station force main discharge, and at other locations exposed to excessive hydrogen sulfide concentrations, shall conform to the following:
  - 1. After manhole has been constructed, but prior to it receiving any flow, the entire interior of the structure shall be coated with Spectrashield, OBIC, or approved equal. See 02605.2.11.

## **02605.2.03 MANHOLE STEPS**

- A. Steps shall be installed at twelve (12) inch intervals. The vertical line of manhole steps shall be plumb. No step(s) shall be offset horizontally from the other steps.
- B. Steps shall conform to one of the following (See Standard Detail S-7 or S-8):
  - 1. Steel reinforced polypropylene with serrated tread and end lugs as manufactured by M.A. Industries Inc. (Model PS2-PF-DRP), or approved equal.
  - 2. Aluminum 6061-T6 alloy, drop front, safe tread as manufactured by Nenah Foundry (Model R-1982-W), or approved equal.

#### **02605.2.04 PIPE TO MANHOLE/VAULT CONNECTION**

- A. Resilient Pipe-to-Manhole Connection shall be rubber gasket, compression type connector, conforming to ASTM C923, and integrally cast into the manhole or vault wall, as indicated on the Drawings. The rubber gasket type seals must be manufactured so as to be properly mated to the type and size of the sewer pipe being used. Compression between the installed gasket and pipe shall form a flexible, watertight seal. Gaskets shall be X-Cel, as manufactured by A-Lok Products, Inc. of Tullytown, Pennsylvania, EconoSeal, as manufactured by Press-Seal Corporation of Fort Wayne, Indiana, or approved equal. Gaskets requiring a mechanical means of compression to form a seal are prohibited.

#### **02605.2.05 JOINT SEALANT COMPOUND**

- A. Joint Sealant Compound shall be in accordance with FS-S-00210 and ASTM C990, preformed, flexible, self-adhering, cold-applied, as manufactured by A-Lok Products Inc. ("Butyl-Lok"), K.T. Snyder Company, Inc. ("Ram-Nek"), or approved equal, to provide a watertight joint under all conditions of service.

#### **02605.2.06 EXTERIOR JOINT SEALANT**

- A. Provide heat activated, high shrink membrane for prevention of groundwater infiltration.
  - 1. On all manholes a chimney seal shall be provided that encapsulates the outside of the frame and grade rings. Chimney Seal shall be "Wrapid Seal", manufactured by CANUSA, or approved equal.
  - 2. In wetland, floodplain, or high groundwater areas, the Authority may require that all exterior manhole joints, including the grade adjustment course be wrapped. Wrap shall be applied per manufacturer's instructions with a 12-inch minimum width. Exterior joint sealant shall be "Wrapid Seal", manufactured by CANUSA, or approved equal.

#### **02605.2.07 MATERIALS PROTECTION**

- A. All outside surfaces of manholes and vaults shall receive two (2) coats of Koppers 300-M epoxy coating, or approved equal, with a minimum dry film thickness of 16 mils. The concrete surfaces shall be cleaned and free from all loose concrete or soil particles before application of any coatings. The coating shall be placed on entire exterior surfaces from the top of bottom slab to bottom of the frame and cover. The protective coating may be shop coated.
- B. The inside surfaces of manholes receiving force main connections, and the next two successive downstream manholes, shall receive an interior lining system. See Section 02605.2.02.D for requirements.

## **02605.2.08 GRADE ADJUSTMENT RINGS**

- A. For top grade adjustment ring, provide a rubber composite grade adjustment ring in diameter and thicknesses (between 1/2-inch and 3-inch), as required. Polyurethane joint sealant/adhesive shall be installed in a continuous ring on the bottom and top of the adjustment ring. Adjustment ring shall be "Infra-Riser", as manufactured by East Jordan Iron Works, or approved equal. Shall be PennDOT approved product.
- B. Additional grade adjustment rings can be a combination of concrete and/or rubber composite grade rings. Concrete grade rings shall be set with mortar to required grade pitch. Rubber composite grade rings shall be set with Polyurethane joint sealant/adhesive.
- C. The minimum thickness of a concrete grade adjustment ring shall be 1" thick.

## **02605.2.09 MANHOLE FRAME AND COVERS**

- A. Manhole frames and covers (See Standard Details S-5 and S-6) shall be required as follows:
  - 1. Watertight frames with bolt-down covers shall be installed on all interceptor manholes, on all manholes located in floodplain, floodprone, or ponded areas, and as directed by the ENGINEER, or as specified in Paragraph 2.09.B. Covers shall be bolted to the frame with four (4) 1/2-inch countersunk, stainless steel hex-head bolts. A continuous o-ring gasket shall be glued to the frame to provide a watertight seal between the frame and bolted cover. Each cover shall have two (2) concealed pickholes, and a non-skid, diamond top design. Watertight frames and covers shall be Neenah Foundry Company Model R-1916-F, East Jordan Company, or approved equal.
  - 2. Standard frames shall be installed at all other locations unless otherwise specified. Standard frames and covers shall be provided with self-sealing gasket type cover with concealed pickholes. Gasket shall be preinstalled and glued firmly in place at the factory, and shall be one continuous piece fitting securely within a dovetailed groove in the cover. Each cover shall have two (2) concealed pickholes, and a non-skid, diamond top design. Standard frames and covers shall be Neenah Foundry Company Model R-1642, East Jordan Company, or approved equal.
  - 3. Vented covers shall be used only in special applications (elevated rims), and only as directed by the ENGINEER. Vented manhole covers, when required, shall have two (2) concealed pickholes, and a non-skid, diamond top design. Vented manhole covers shall be Neenah Foundry Company Model R-1653-F, or approved equal. Solid covers with through-the-lid pickholes may be substituted.
  - 4. All manhole frames shall have a minimum clear opening of 24" and be cast with four (4) 7/8" minimum diameter holes equally spaced and be bolted to the top section of the manhole riser with four (4) 3/4-inch all thread stainless steel bolts.
- B. The elevation of manhole rims shall be at street surface except as follows:
  - 1. One (1) foot above 100-year flood elevation in flood plains and flood prone areas (watertight frames with bolt-down covers shall be installed in these areas.)

2. 12" above grade in unmaintained easement areas not subject to flooding (watertight frames with bolt-down covers shall be installed in these areas.)
  3. At grade in maintained lawn areas (either watertight frames with bolt-down covers or standard frames with self-sealing, gasket type covers shall be installed in these areas.)
- C. Castings shall be gray cast iron, suitable for AASHTO Highway Loading Class HS-20, and conform to ASTM A48, Class 35. Casting shall be of uniform quality, free of bubbles, sand, air holes, hard spots, shrinkage, defects, cracks or other imperfections. They shall be smooth and well cleaned by shot blasting and, unless otherwise specified, shall be coated with black asphaltic paint.
- D. All castings shall be manufactured true to pattern and with a close fit of component parts. Round frames and covers shall be of no-rocking design and contact surfaces shall be machined and matched so that fitting parts will not rock.
- E. A notarized certificate shall be submitted if required by the OWNER verifying the minimum tensile strength of the casting of 35,000 psi. All manhole casting shall be made accurately to the pattern and to the dimensions shown on Plans, and shall be planed where marked, or where otherwise necessary to secure perfectly flat and true surfaces. All lids which "rock" and do not lie solid after construction is finished will be condemned and must be replaced.
- F. All covers shall have one of the following phrases cast thereon in two (2) inch letters:
1. For sanitary sewer covers: "BCWSA SANITARY SEWER" or the words "BCWSA S DANGER KEEP OUT"
  2. For public water covers: "BCWSA W DANGER KEEP OUT"

#### **02605.2.10 MANHOLE INFLOW PREVENTION INSERTS**

- A. Provide manhole inserts for the prevention of stormwater inflow, where required by ENGINEER. The body of the insert shall be made of high density polyethylene copolymer conforming to ASTM D1248 Class A, Category 5, Type 111. The insert shall have a minimum 1/8 inch or greater thickness throughout. A gasket made of closed cell neoprene with a pressure sensitive adhesive on one side shall be installed by the manufacturer on the insert.
- B. The insert shall be provided with a lift strap and vent hole. The lift strap shall be placed on the rising edge of the inset bowl and shall be one inch wide polypropylene web. The location of the strap shall be attached by means of a stainless steel rivet and be located such as to provide easy visual location.
- C. The insert shall be Knutson as supplied by J.C. Utility Sales Inc., Dallas, Texas, Parson Environmental Products, Inc., or approved equal.

### **02605.2.11 MANHOLE LINING**

- A. Provide a total liner system of manhole by a company that specializes in the design, manufacture and installation of corrosion protection systems for manholes. Applicator shall be completely trained in leak repair, surface preparation and corrosion materials application on manholes. Corrosion materials/products shall be suitable for installation in a severe hydrogen sulfide environment without any deterioration to the liner.
- B. The applicator shall be trained and certified by the manufacturer for the handling, mixing, application and inspection of the liner system as described herein.
- C. The lining system to be utilized for manhole structures shall be a multi-component stress skin panel liner system with a moisture barrier of modified polymer, an intermediate surfacer of polyurethane/polymeric blend foam, and final corrosion barrier of modified polymer. The modified polymer shall be sprayable, solvent free, two-component polymeric, moisture/chemical barrier specifically developed for the corrosive wastewater environment.
- D. Product shall be Spectrashield, by CCI Spectrum, Inc., OBIC Armor 1000, or approved equal. Installation to be in accordance with manufacturer's specific instructions, performed by a licensed applicator of the product. Manufacturer and Applicator shall warrant the manhole liner against failure for a period of 10 years.

## **PART 3 - EXECUTION**

### **02605.3.01 EXCAVATION**

- A. Perform excavation to the line and grade shown on the design plans and as specified in Section 02220. Excavation and backfill limit for all manholes and vaults is to be one (1) foot around the outside diameter of the structure.
- B. Location and depth of manholes and vaults are to be as shown on the design plans and as directed by ENGINEER.

### **02605.3.02 CONSTRUCTION**

- A. Construct watertight manholes of precast concrete sections and of the type noted on the design plans in accordance with Standard Details S-1, S-2, S-3 and S-4 and ASTM C478. The CONTRACTOR shall provide sufficient labor and equipment to unload and place the units. All precast sections of manholes shall be lifted and moved by use of suitable lifting slings and lugs to prevent damage to the precast joint edge. If minor damage occurs to the precast sections, such damage will be repaired in the presence of, and to the satisfaction of the ENGINEER or AUTHORITY.

- B. Outside drop manholes shall be provided where the invert drop is one foot six inches (1'-6") or more, or as required by the ENGINEER. Construct drop connections as indicated on Standard Detail S-4. A precast drop manhole base with an integrally cast 90° bend shall be used for all drop connections. Precast U-shaped collars shall be installed to support the riser. Class C concrete shall be used to encase the tee branch, and to fill the void space between the collars and the manhole wall. The drop connection shall be of the same pipe material used to construct the main. Where approved by the ENGINEER, an inside drop for main line sewers may be considered for up to a maximum of 1'-6" between pipe invert and manhole invert.
- C. Construct doghouse manholes on existing pipelines as indicated on Standard Detail S-3. Carefully excavate around existing pipeline for placement of the new manhole base. Take all measures necessary to control flow through the existing pipeline and to prevent leakage into the new base. New bench and flow channels shall be constructed of Class C, 2,500 psi concrete in manhole base, as shown on the design plans. Channel depth shall be (3/4) the largest pipe diameter in the manhole. Slope channels uniformly from influent invert to effluent invert. Slope bench towards channel at one (1) inch per foot. Construct bends of the largest possible radius and form channel sides and invert smooth and uniform, free of cracks, holes, or protrusions. After completion of the manhole, carefully remove the top portion of the existing pipeline and portion within the new channel.
- D. Install precast base on a minimum of six (6) inches of coarse aggregate subbase, leveled and compacted. Leveling of structures by use of wedges or shims will not be permitted. Manholes shall not be backfilled without the permission of and the prior inspection by the ENGINEER.
- E. An integral resilient connection shall be provided at each pipe location, which will serve as a watertight seal. Pipes entering or exiting precast sections shall be set securely in the opening provided, to the correct line and grade shown on the Drawings.
- F. Install sewer connections to manhole base.
1. The maximum length of pipe for all connections where soft or unstable soil conditions exist (undercut, install, and compact stone until base is stable) shall be:
    - a. Six (6) feet for new precast base.
    - b. Two (2) feet for new cast-in-place base and connections to existing base.
  2. Pipe shall not project more than 2" into the manhole.
  3. The bottom portion of the annular space around the sewer pipe within the inside of the manhole shall be filled with non-shrink grout to match the channel. No grout shall be used on the upper portion of the annular space or in the exterior annular space.
- G. Seal joints between precast concrete sections with two (2) rings of preformed joint sealant compound. One ring of joint sealant compound shall be applied to both inside and outside flanges on the lower section of the unit section groove allowing sealant to be squeezed by the weight of the upper section. The use of round rubber gaskets for sealing manhole joints shall not be permitted. Seal exterior joints as specified in Section 02605.2.06.

- H. Install manhole and vault sections with steps in proper vertical alignment.
- I. Openings for lifting precast concrete vault and manhole bases, walls, and sections shall be filled with non-shrink waterproof grout.
- J. Install manhole and vault frames and covers.
  - 1. Set top of frames to finished grade elevation or other elevation shown on the design plans.
  - 2. Anchor manhole frame to the precast structure at four (4) locations as per the Detail Drawings.
  - 3. Grade adjustments of the frames shall be made using precast concrete manhole grade rings. The use of brick will not be permitted. The grade rings shall conform to the requirements of ASTM C-478 and shall be a minimum of two (2) inches thick. The top grade ring shall be made of a rubber composite and sealed per manufacturer's instructions.
  - 4. The joint between the manhole frame and the top grade adjustment rings shall consist of glue and/or a double ring of preformed plastic sealing compound. Absolutely no mortar shall be used in this joint.
  - 5. A one-half (1/2) inch thick coat of mortar shall be neatly placed around the outside of the grade ring. Absolutely no mortar shall coat the inside of the grade adjustment rings.
  - 6. The maximum height of all grade adjustments shall be twelve (12) inches, measured from the top of the upper manhole section to the bottom of the frame.
  - 7. Install chimney seal as specified in Section 02605.2.06.
- K. Manholes and vaults shall be placed as promptly as practical to coincide with the adjacent sewer pipe construction. If the construction of manholes and vaults is unnecessarily delayed, the AUTHORITY shall have the ability to stop trenching and pipe laying activities until the structures are satisfactorily installed to complete sections of sewer. Manholes may not be left open during construction, after they have been completed, or overnight. If the manhole is not completed by the end of the working day, the CONTRACTOR must use a safe, temporary method of covering and securing the manhole opening.
- L. Where new manholes are to be constructed on existing pipelines, carefully excavate around existing pipeline for placement of the new cast-in-place manhole base in accordance with Standard Detail S-3. Take all measures necessary to control flow through the existing pipeline and to prevent leakage into the new base. After completion and testing of the manhole, carefully remove the top portion of the existing pipeline.

M. For connections to an existing manhole:

1. Provide a carefully bored opening in the manhole wall no larger than two (2) inches around the new pipe and modify the existing bench to create a new channel, which shall be finished with non-shrink grout and troweled to meet existing channel. The CONTRACTOR shall take all necessary precautions to prevent cutting debris from entering the existing sewage flow.
2. The first section of new pipe out of the manhole must be a bell section no longer than six (6) feet and set on line and grade. Install an approved water stop around the new pipe and position the pipe to the correct alignment; fill and seal the annular space between the gasket and the existing manhole wall with non-shrink grout. The waterstop shall be the CMA Concrete Manhole Adapter as manufactured by Fernco or Inserta-LOK as manufactured by A-Lok Products, Inc, or approved equal.

#### **02605.3.03 BACKFILLING**

- A. Backfill only after examination of the manhole by the Resident Project Representative.
- B. Perform backfilling as specified in Section 02220.

#### **02605.3.04 TESTING**

- A. Manholes and vaults shall be tested for leakage in accordance with Section 02650.

#### **02605.3.05 SITE RESTORATION WORK**

- A. Once the manholes, vaults, and related sanitary sewer construction has been completed in an area, the following site restoration work shall be completed in accordance with the design plans and as specified in the noted Sections:
  1. Finish Grading, Section 02905 - Landscaping
  2. Replace Topsoil and Seed, Section 02905 - Landscaping
  3. Pavement Restoration, Section 02575 - Restoration of Paved Surfaces
- B. CONTRACTOR shall stage site restoration work for a large project in accordance with the construction schedule approved by ENGINEER.

**END OF SECTION**

**SECTION 02610  
UTILITY PIPE AND FITTINGS**

**PART 1 – GENERAL**

**02610.1.01 SUMMARY**

A. Section Includes:

1. Public water main
2. Public water services
3. Gravity sanitary sewer
4. Sanitary sewer force main
5. Low pressure sanitary sewer
6. Sanitary sewer laterals

B. The CONTRACTOR shall supply all necessary labor, materials, and equipment for the installation and testing of water mains and water service piping, sanitary sewer mains and lateral piping, and sewage force mains as indicated on the Drawings.

**02610.1.02 RELATED INFORMATION**

A. Related Sections:

1. Section 02250 – Environmental Protection
2. Section 02170 – Stream Crossing
3. Section 02220 – Excavation, Backfill and Compaction
4. Section 02229 – Rock Removal
5. Section 02300 – Boring or Jacking Operations
6. Section 02575 – Restoration of Paved Surfaces
7. Section 02605 – Manholes and Vaults
8. Section 02650 – Water and Sanitary Sewer System Testing
9. Section 02905 – Landscaping
10. Section 03302 – Concrete Work for Utilities

B. Associated Construction Details:

1. M-1 – Standard Pipe Bedding
2. M-2 – Concrete Encasement
3. S-9 – Lateral Connection - Shallow Sewer
4. S-10 – Lateral Connection - Deep Sewer
5. S-12 – Cleanout Protection Sleeve
6. S-13 – Sewer Saddle

### 02610.1.03 QUALITY ASSURANCE

#### A. Reference Standards:

1. American National Standards Institute (ANSI) /  
American Water Works Association (AWWA)
  - A21.4/C104 Cement-Mortar Lining for Ductile-Iron Pipe and Fittings for Water
  - A21.5/C105 Polyethylene Encasement for Ductile-Iron Piping for Water and Other Liquids
  - A21.10/C110 Ductile-Iron and Gray-Iron Fittings, 3-inch through 48-inch, for Water and Other Liquids
  - A21.11/C111 Rubber-Gasket Joints for Ductile-Iron and Gray-Iron Pressure Pipe and Fittings
  - A21.15/C115 Flanged Ductile-Iron Pipe with Ductile-Iron or Gray-Iron Threaded Flanges
  - A21.50/C150 Thickness Design of Ductile-Iron Pipe
  - A21.51/C151 Ductile-Iron Pipe, Centrifugally Cast in Metal Molds or Sand-Lined Molds, for Water and Other Liquids
  - A21.53/C153 Ductile-Iron Compact Fittings, 3-inch through 16-inch, for Water and Other Liquids
2. American Society for Testing and Materials (ASTM):
  - D1785 Specification for Poly (Vinyl Chloride) (PVC) Plastic Pipe, Schedules 40, 80, and 120
  - D2466 Specification for Poly (Vinyl Chloride) (PVC) Plastic Pipe Fittings, Schedule 40
  - D3034 Specification for Type PMS Poly (Vinyl Chloride) (PVC) Sewer Pipe and Fittings
  - D3212 Specification for Joints for Drain and Sewer Plastic Pipes Using Flexible Elastomeric Seals
  - F477 Specification for Elastomeric Seals (Gaskets) for Joining Plastic Pipe
  - F679 Specification for Poly (Vinyl Chloride) (PVC) Large-Diameter Plastic Gravity Sewer Pipe and Fittings

- B. Acceptable Manufacturer:
1. The pipe, fittings and associated items shall be provided by a firm regularly engaged in the manufacture of such products of the types, materials and sizes required, whose products have been in satisfactory use in similar service for not less than five (5) years.
  2. Ductile iron pipe and fittings shall be provided by one of the following manufacturers, or approved equal.
    - a. U.S. Pipe and Foundry Company
    - b. Griffin Pipe Products Company
    - c. Atlantic States Cast Iron Pipe Company
    - d. Tyler/Union
    - e. McWane Ductile
  3. Polyvinyl chloride (PVC) pipe and fittings shall be provided by one of the following manufacturers, or approved equal.
    - a. J-M Manufacturing Company, Inc.
    - b. North American Pipe Company
    - c. Charlotte Pipe & Foundry
    - d. Multi Fittings Corporation
    - e. Harrington Corporation (HARCO)
  4. High density polyethylene (HDPE) pipe and fittings shall be provided by one of the following manufacturer's, or approved equal.
    - a. Lamson Vylon Pipe of Cleveland, Ohio
    - b. Performance Pipe of Plano, Texas
    - c. Harrington Corporation (HARCO) of Lynchburg, Virginia
    - d. Central Plastics Company of Shawnee, Oklahoma
    - e. CEPEX
  5. Copper tubing shall be manufactured by Mueller Industries, Inc. of Memphis, Tennessee, or approved equal.
- C. Reject materials contaminated with gasoline, lubricating oil, liquid or gaseous fuel, aromatic compounds, paint solvent, paint thinner, or acid solder.
- D. Pipe strengths specified shall be provided unless otherwise indicated on the Drawings. Pipe fittings shall be of the same strength rating as the piping on which they are installed.
- E. Potable water system products shall bear the seal of approval of the National Sanitation Foundation (NSF).

#### **02610.1.04 SUBMITTALS**

##### **A. Manufacturer's Literature:**

1. Submit manufacturer's descriptive literature for the following items:
  - a. Pipe, pipe fittings, joints, joint gaskets, joint restraints, and lubricants.
2. Submit manufacturer's certificate certifying that the pipe and pipe fittings were manufactured and tested in accordance with the applicable standards.
3. Submit manufacturer's instructions for installation of adapters and for assembly of mechanical, push-on and compression type joints, including the manufacturer's maximum recommended deflection per joint. Submit tightening torque requirements for anchor studs, set screws, and bell bolts.
4. Submit shop drawings for all shop fabricated materials which, in the judgment of the ENGINEER, require such drawings for the satisfactory performance of the Work specified herein in this section of the Specifications.
5. All pipe shall be covered by a guarantee certificate furnished by the CONTRACTOR and signed by an officer of the pipe manufacturer.

#### **02610.1.05 PRODUCT DELIVERY, STORAGE, AND HANDLING**

##### **A. Delivery and Handling:**

1. A packing list shall accompany every delivery made to the site and shall contain complete information, including kind and class of pipe, diameter, weight per pipe, length of pipe, and date or other plant identification of the particular lot of pipe contained in the shipment. A copy of the packing list shall be submitted to the ENGINEER or AUTHORITY as soon as practicable after the delivery of the pipe to the job site.
2. Do not place materials on private property without written permission of the property owner.
3. During loading, transporting and unloading, take measures to prevent damage to the exterior surface or internal lining of the pipe. The hook - sling method of lifting pipe, in which hooks or similar devices are inserted into each end of the pipe for lifting, will not be permitted. One acceptable method would be the use of the single or double sling, which is placed around the barrel of the pipe. Pipe being unloaded on skids shall not be rolled or skidded against pipe already on the ground.
4. Do not drop pipe or fittings. Avoid shock or damage at all times.

B. Storage:

1. Pipe may be strung along alignment where approved by the ENGINEER.
2. Do not stack pipe higher than recommended by the pipe manufacturer.
3. Store gaskets for mechanical and push-on joints in a cool, dry location out of direct sunlight and not in contact with petroleum products.
4. PVC pipe shall be protected from exposure to ultraviolet light.

**02610.1.06 WATER AND SANITARY SEWER MAIN PIPE MATERIAL SELECTION**

- A. All buried water and sanitary sewage pressure mains shall be Class 52 ductile iron pipe minimum or where the pipe is to be nominal 12” or less, may be polyvinyl chloride (PVC) pressure pipe (ANNSI/AWWA C900), with gasketed push-on type and/or mechanical joints.
- B. All buried gravity sanitary sewer mains shall be Class 50 ductile iron pipe minimum or polyvinyl chloride (PVC) pipe SDR-26. All piping to be gasketed push-on and/or mechanical joints.
- C. All low pressure sanitary sewer (LPSS) mains shall be polyvinyl chloride (PVC) pressure pipe SDR-11 or SDR-21 (minimum). PVC pipe shall be gasketed push-on joints. Low pressure laterals to be HDPE DR-11.
- D. Ductile iron pipe shall be required for all sanitary sewers outside of roadway right-of-ways (in easements) and/or that cross areas of high groundwater (floodplains, stream crossings, wetlands) and where depth to crown of sewer is greater than twelve-feet (12’). C-900 PVC may be substituted for DIP in these areas with OWNER’s approval, if cover over top of pipe for entire run is less than 12 feet. A sewer segment between manholes shall consist of the same type of pipe material based on the maximum depth encountered. Change of pipe material between manholes will not be permitted.
- E. All ductile iron pipe and fittings located inside structures shall be flanged ductile iron pipe in accordance with ANSI A21.15/AWWA C115 Class 53.
- F. For force mains, if total length from valve vault to discharge is greater or equal to 1,500 linear feet, a line plug valve with valve box should be added towards the middle of the length. So if force main length is 1,500 linear feet, the line valve should be added approximately 750 feet from the valve vault.

**PART 2 - PRODUCTS**

**02610.2.01 DUCTILE IRON PIPE FOR WATER AND SEWAGE FORCE MAINS**

- A. Buried Piping
  1. Pipe:

- a. Ductile Iron pipe, ANSI A21.51 / AWWA C151, Thickness Class 52 (minimum).
- b. Double thickness cement-mortar lining and seal coat, ANSI A21.4 / AWWA C104.
- c. All pipe shall be provided with an asphaltic outside coating.

2. Fittings:

- a. Standard or compact ductile iron fittings, ANSI A21.10 / AWWA C110 or ANSI A21.53 / AWWA C153, Class 350.
- b. Provide double thickness cement-mortar lining and seal coat and an asphaltic outside coating, consistent with the ductile-iron pipe.
- c. All fittings shall be mechanical joint and be provided with “Mega-Lug” thrust restraint, or approved equal, and concrete thrust blocks.

3. Joints:

- a. Where not specifically shown on the Drawings, pipe joints (except fittings) may be either mechanical joint or push-on joint, ANSI 21.11 / AWWA C111. Fittings shall have mechanical joints only conforming to ANSI 21.11 / AWWA C111.
- b. Rubber gaskets, lubricants, glands, bolts and nuts: ANSI A21.11 / AWWA C111.

B. Piping in Structure

1. Pipe:

- a. Ductile iron flanged pipe, ANSI A21.15 / AWWA C115, Thickness Class 53 (minimum).
- b. Double thickness cement-mortar lining and seal coat, ANSI A21.4 / AWWA C104.
- c. All pipe located inside structures shall be primed with an epoxy polyamide exterior coating, minimum 4 mils DFT (TNEMEC Series 66, or approved equal).

2. Fittings:

- a. Flanged ductile iron fittings, ANSI A21.10 / AWWA C110 or ANSI A21.53 / AWWA C153, Class 125 drilling, full face.
- b. Provide double cement-mortar lining and seal coat and a primed outside coating, consistent with the flanged pipe.

- c. Fittings shall have mechanical joints only conforming to ANSI 21.10 / AWWA C110.

3. Joints:

- a. Flanged joints shall be flat faced, gasketed and bolted, conforming to ANSI A21.10 / AWWA C110, ANSI A21.15 / AWWA C115, and ANSI B16.1, Class 125. Raised face flanges will not be permitted.
- b. Gaskets shall be full faced (ring gaskets shall not be used) rubber, one-eighth (1/8") inch thick conforming to ASTM C425 and ANSI A21.10 / AWWA C110.
- c. All nuts and bolts for flanged joints shall be low alloy steel conforming to the requirements of ANSI B18.2. All nuts and bolts in buried or corrosive applications shall receive a heavy coating of bituminous material.

**02610.2.02 DUCTILE IRON PIPE FOR GRAVITY SEWER**

A. Pipe:

- 1. Ductile Iron pipe, ANSI A21.51 / AWWA C151, Thickness Class 50 (minimum).
- 2. Double thickness cement-mortar lining and seal coat, ANSI A21.4 / AWWA C104.
- 3. All pipe shall be provided with an asphaltic outside coating.

B. Fittings:

- 1. Standard or compact ductile iron fittings, ANSI A21.10 / AWWA C110 or ANSI A21.53 / AWWA C153, Class 350.
- 2. Provide double thickness cement-mortar lining and seal coat and an asphaltic outside coating, consistent with the ductile-iron pipe.
- 3. All fittings shall be push-on or mechanical joint.

C. Joints:

- 1. Where not specifically shown on the Drawings, pipe joints may be either mechanical joint or push-on joint, ANSI 21.11 / AWWA C111.
- 2. Rubber gaskets, lubricants, glands, bolts and nuts: ANSI A21.11 / AWWA C111.

### **02610.2.03 POLYETHYLENE ENCASUREMENT FOR DUCTILE IRON PIPE**

In areas with corrosive soils or stray current, all pipe, fittings, and appurtenances shall be installed with polyethylene encasement. In the event the Drawings do not indicate any encasement or the limits of the encasement, the decision of the ENGINEER shall determine the location where the encasement shall be used. All costs related to soil sampling, analysis, and inspection shall be borne by the CONTRACTOR. The polyethylene encasement shall be 8 mils thick and installed in accordance with Method A of ANSI A21.5 / AWWA C105.

### **02610.2.04 POLYVINYL CHLORIDE (PVC) PIPE FOR WATER AND SEWAGE FORCE MAINS**

#### **A. Pipe:**

1. Pipe shall conform to AWWA C900-07 and FM 1612. Pipe material shall conform to ASTM Standard D1784, with maximum pipe laying length of 20-feet.
2. The minimum rated fittings that will be accepted are Class 52 Ductile Iron Pipe.
3. PVC pressure pipe shall have a minimum wall thickness such that the maximum dimension ratio (DR) is 18. All PVC pressure pipe shall have outside diameter equivalent to ductile iron pipe.
4. Magnetic-type locator tape shall be laid directly over the top of PVC pipe, two-feet (2') below grade.
5. Tracer wire (See Section 02519).

#### **B. Fittings:**

1. All fittings for DIP and/or PVC water mains and force mains shall be standard or compact ductile iron fittings, ANSI A21.10 / AWWA C110 or ANSI A21.53 / AWWA C153, Class 350. Mechanical joints shall be made in strict accordance with the recommendations of the joint manufacturer and suitable to the pipe for which it is being used.
2. Provide double thickness cement-mortar lining and seal coat, ANSI A21.4 / AWWA C104, and an asphaltic outside coating.
3. All fittings shall be mechanical joint and be provided with "Mega-Lug" thrust restraint, or approved equal, and concrete thrust blocks.
4. For PVC to DIP unrestrained connections, use a Dresser Style 153 coupling or as approved by the AUTHORITY or ENGINEER.

- #### **C. Joints:**
- All joints (except fittings) shall be push-on type using flexible elastomeric seals meeting the requirements of ASTM D3139. Elastomeric seal material shall be in accordance with ASTM F477.

## **02610.2.05 PVC PIPE FOR GRAVITY SEWER AND LATERALS**

- A. Pipe:
1. Gravity mains shall be SDR-26: ASTM D3034, F679. SDR-35 permitted for laterals only.
  2. Pipe shall have smooth inner walls and maximum pipe laying length shall be 20-feet.
  3. Magnetic-type locator tape shall be laid directly over the top of PVC pipe, two-feet (2') below grade.
- B. Fittings: PVC gasketed sewer fittings, suitable for use with SDR 26 PVC (mains) or SDR 35 PVC for laterals. Fittings shall be one-piece molded fitting with no glued joints.
- C. Joints: Integral bell flexible elastomeric seals: ASTM D3212 Seal Material: ASTM F477
- D. In special cases, BCWSA may require the use of C-900 pipe for gravity sewer in lieu of SDR-26, due to depth of the pipe, location, or other. In these cases, C-900 shall conform to AWWA C900-07, FM 1612.

## **02610.2.06 PVC PIPE FOR LOW PRESSURE SEWAGE FORCE MAINS**

- A. Pipe:
1. Buried pipe shall be PVC SDR-21: ASTM D1784, ASTM 2241
  2. Pipe within valve vaults shall be PVC Schedule 40 in accordance with ASTM D1785.
  3. Pipe within existing or new sewer manholes to which a low pressure sewer discharges shall be PVC Schedule 80 in accordance with ASTM D1785.
  4. Pipe shall have smooth inner walls and maximum pipe laying length shall be 20-feet
  5. Magnetic-type locator tape shall be laid directly over the top of PVC pipe, two-feet (2') below grade.
  6. Tracer wire for mains (See Section 02519).
- B. Fittings:
1. Buried fittings shall be Iron Pipe Size (IPS) manufactured in one piece of injection molded PVC compound meeting ASTM D1784 and ASTM D2241, Class 200 and conform to the requirements of SDR 21. Bell shall be gasketed joint conforming to ASTM 3139 with gaskets conforming to ASTM F477.
  2. Fittings within valve vaults shall be PVC SDR-21 and be in accordance with ASTM D2466.

3. PVC fittings within existing or new sewer manholes shall be threaded, in accordance with ASTM D2464.
- C. Joints: All pipe joints shall be push-on type using flexible elastomeric seals that comply with the requirements of ASTM F477.

#### **02610.2.07 HDPE PIPE FOR LOW PRESSURE SEWAGE LATERALS**

- A. High Density Polyethylene (HDPE) pipe and fittings shall conform to ASTM D3035 and ASTM F714 – SDR 11, PE 3408, IPS (OD). All joint connections shall be made using compression fittings conforming to ASTM D3035, butt fusion in accordance with guidelines published by the Plastics Pipe Institute, or electrofusion fittings conforming to ASTM F1055.
- B. Fittings shall be of the same or greater pressure class as the pipe to which they are installed. Fittings shall be IPS (OD). The following fittings may be used, depending on site specific conditions:
1. Compression fittings manufactured from polypropylene compound. Fittings shall have outside o-ring sealed compression ends, color coded to match specific piping used. Compression fittings shall be as manufactured by Cepex, or approved equal.
  2. Butt Fusion fittings manufactured in accordance with ASTM D3261 and ASTM D3350. Butt fusions should be made only by trained operators using specially developed butt fusion machines that secure and precisely align the pipe ends for the fusion process. Butt fusion fittings shall be as manufactured by Central Plastics Company of Shawnee, Oklahoma, or approved equal.
  3. Electrofusion fittings manufactured in accordance with ASTM F1055 and ASTM D3350. Electrofusion fittings shall be installed only by persons that have received training from an authorized instructor, and have a strong working knowledge of polyethylene and heat fusion, and have qualified electrofusion joints through destructive testing. Persons responsible for the joining of polyethylene pipes by fusion methods must qualify according to the requirements of Title 49 Code of Federal Regulations, Section 192.285. Fittings shall be constructed of pre-blended black high density virgin resin and recognized by the Plastic Pipe Institute as having a PE3408 rating and a Hydrostatic Design Basis of 1600 psi @ 73° F. Heating wire shall be copper, nickel or alloy. Electrofusion fittings shall be as manufactured by Central Plastics Company of Shawnee, Oklahoma, or approved equal.

#### **02610.2.08 STAINLESS STEEL PIPE**

Stainless steel pipe shall be Type 304, Schedule 40, conforming to ASTM A312. Fittings shall be threaded, conforming to ASTM A403 and ANSI B 16.3.

#### **02610.2.09 TUBING FOR WATER SERVICES**

- A. Tubing: ASTM B88, Seamless, Soft Temper, Type K Copper, minimum service size shall be 3/4", unless otherwise approved by the ENGINEER. Installation details of service piping of sizes greater than 1" shall be referred to the AUTHORITY for approval.

- B. Fittings: copper tubing fittings shall be the same size as piping and be cast bronze with compression type joints suitable for underground service. Soldered or flared joints will not be permitted.
- C. Polyethylene Tubing meeting the requirements of ASTM D2337, PE3408, SDR-9 200 psi, AWWA C901 and NSF Standard 14 may be used for water services over 100 feet in length. Polyethylene tubing shall be provided in continuous rolls.
- D. Shut-offs (curb stops) and curb boxes are to be provided at the right-of-way line and at every joint (connection) between rolls of tubing. No buried couplings will be permitted.

#### **02610.2.10 TAPPING SLEEVES AND VALVES**

- A. The tapping sleeve shall be mechanical joint type, Mueller Company Type H-615, or approved equal. The type of pipe and actual outside diameter of the main should be confirmed by the Contractor before placement of order for the sleeve.
- B. The tapping sleeve valve shall be Mueller Company Type H-667, or approved equal, having Class 125 flange inlet for connecting to the sleeve and mechanical joint end on the outlet.

#### **02610.2.11 UNDERGROUND DETECTION TAPE**

- A. Detection tape shall be a minimum six (6) inches wide by 4 mils thick continuous metallic colored ribbon with wording:
  - 1. “CAUTION - WATER LINE BURIED BELOW” on blue tape
  - 2. “CAUTION - SEWER LINE BURIED BELOW” on green tape

### **PART 3 - EXECUTION**

#### **02610.3.01 PREPARATION**

- A. Perform trench excavation to the line and grade indicated on the design plans and as specified in Section 02220.
- B. Unless otherwise indicated on the design plans, provide for a minimum cover of four (4) feet above the top of piping laid in the trench based on the finished grade elevation.
- C. Provide pipe bedding as specified in Section 02220 and as shown on Standard Detail M-1 for each type of pipe used. Place aggregate in a manner to avoid segregation, and compact to the maximum practical density so that the pipe can be laid to the required tolerances.
- D. All water services and sanitary laterals shall be located where shown on the design plans or otherwise as directed by AUTHORITY with input by CONTRACTOR.

### 02610.3.02 LAYING PIPE IN TRENCHES

- A. Give ample notice to the ENGINEER in advance of pipe laying operations. Pipe placement and alignment shall be accomplished only in the presence of the ENGINEER or AUTHORITY. Adequate and suitable equipment and appliances for safe and convenient handling and laying of pipe shall be used.
- B. Prior to being lowered into the trench, each pipe and fitting shall be carefully inspected, and those not meeting specifications or which are otherwise defective shall be rejected and removed from the project. If, in the opinion of the ENGINEER or AUTHORITY, the materials furnished or the methods of installation are not in accordance with the Specifications or generally accepted practices for that type of work, such work may be stopped by the AUTHORITY.
- C. Lower pipe into trench using handling equipment designed for the purpose to assure safety of personnel and to avoid damage to pipe. Do not drop pipe.
- D. Lay pipe proceeding upgrade with the bell or groove pointing upstream.
- E. Use laser alignment instruments, to maintain proper alignment and slope. The CONTRACTOR must check the pipe grade during installation as directed by the ENGINEER.
- F. Lay pipe to a true uniform line with the barrel of the pipe resting solidly in bedding material throughout its length. Excavate recesses in bedding material to accommodate bells, joints, fittings, and appurtenances. Do not subject pipe to a flow or shock to achieve solid bearing or grade.
- G. Lay each section of pipe in such a manner as to form a closed concentric joint with the adjoining section and to avoid offsets in the flow line.
- H. Clean and inspect each section of pipe before joining. Assemble to provide tight, flexible joints that permit movement caused by expansion, contraction, and ground movement. Use lubricant recommended by the pipe or fitting manufacturer for making joints. If unusual joining resistance is encountered or if the pipe cannot be fully inserted into the bell, disassemble joint, inspect for damage, re-clean joint components, and reassemble joint using a new gasket.
- I. Assemble joints in accordance with recommendations of the manufacturer.
  - 1. Push-on Joints:
    - a. Clean the inside of the bell and the outside of the spigot. Insert rubber gasket into the bell recess.
    - b. Apply a thin film of gasket lubricant to either the inside of the gasket or the spigot end of the pipe, or both.
    - c. Insert the spigot end of the pipe into the socket using care to keep the joint from contacting the ground. Complete the joint by forcing the plain end to the bottom of the socket. Mark pipe that is not furnished with a depth mark before assembly to assure that the spigot is fully inserted.

2. Mechanical Joints:

- a. Wash the socket and plain end. Apply a thin film of soapy water. Slip the gland and gasket over the plain end of the pipe. Apply soapy water to gasket.
  - b. Insert the plain end of the pipe into the socket and seat the gasket evenly in the socket.
  - c. Slide the gland into position, insert bolts, and finger-tighten nuts.
  - d. Bring bolts to uniform tightness. Tighten bolts 180-degrees apart, alternately.
  - e. Coat all bolts and nuts with bitumastic paint after installation.
- J. Check each pipe installed as to line and grade in place. Correct deviation from line and grade immediately. A deviation from the designed grade as shown on the design plans, or deflection of pipe joints, will be cause for rejection.
- K. Place sufficient compacted embedment material on each section of pipe, as it is laid, to hold firmly in place; 2A modified aggregate for ductile iron pipe, or AASHTO #8 aggregate for PVC pipe, as shown on the standard details, to a point one (1) foot above the top of the pipe where a metallic tracer strip be placed. Any section of pipe disturbed after it is set must be reset by the contractor as directed by the ENGINEER.
- L. During construction, the CONTRACTOR shall use all precautions to keep the pipeline clean and clear of deposits and free from injury until finally inspected and accepted. When the work is not in progress, and at the end of each work day, securely plug open ends of pipe and fittings with an expanding rubber plug or approved device to prevent trench water, earth, or other substances from entering the pipes or fittings.
- M. Keep trenches and excavations free of water during construction. No joints shall be made underwater. Water shall not be allowed to rise in the excavation until joint is complete. Care shall be used to secure watertightness and to prevent damage to joints during backfilling. All pipe joints shall be watertight within allowances established by these Specifications.
- N. No pipe shall be laid upon a foundation into which frost has penetrated, nor any time when the ENGINEER or AUTHORITY shall deem that there is a danger of formation of ice or penetration of frost at the bottom of excavation. Where the foundation is unstable or consists of rock, a stone or gravel foundation shall be placed and tamped to form an acceptable bed for the pipe.
- O. Where sanitary sewer pipe crosses under water or gas lines, 18" of vertical separation shall be maintained. Where 18" of vertical separation cannot be maintained, the sanitary sewer shall be concrete encased 10 feet either side of the crossing. Refer to Detail M-2 for concrete encasement requirements. Also, when crossing water or gas lines, sewer joints shall be equidistant and as far as possible from the water or gas joints.
- P. The maximum length of pipe for all connections to precast manhole bases shall be 6 feet. The maximum length of pipe for all connections to poured-in-place bases and connections to existing manholes shall be 2 feet.

- Q. If pipe must be cut to fit as closing pieces, such cuts shall be evenly and squarely made in a workmanlike manner with approved equipment. Injury to linings or coatings shall be satisfactorily repaired. For pipe cut in the field, end of pipe shall be cut square and ragged edges removed with a cutting tool and/or a file.
- R. Where pipe is laid on a radius or curvature, each section of pipe shall be deflected at its joint equally with each adjacent pipe. Maximum allowable deflection shall be one-half the manufacturers recommended deflection.
- S. The minimum slope of 8" gravity sewers shall be 0.005 feet per foot, excluding terminal runs which shall have a minimum slope of 0.01 feet per foot.

### **02610.3.03 SANITARY TEE BRANCHES AND SADDLE**

- A. Install tee branches concurrent with pipe laying operations for each proposed lateral. Use standard fittings of the same material and joint type as the pipeline into which they are installed. Rotate tee branch such that sanitary lateral elevation will be at or higher than the crown of the sewer line.
- B. For taps into an existing pipeline use a saddle tee with stainless steel clamps in accordance with Detail S-13, and as manufactured by Romac, or approved equal. Layout holes with a template and cut holes with a mechanical hole cutter.
- C. Tee-wye fittings will only be permitted if approved by ENGINEER.

### **02610.3.04 LATERALS**

- A. Lateral pipe placement and alignment shall be in accordance with Section 02610.3.03 and accomplished only in the presence of the ENGINEER or AUTHORITY.
- B. Construct laterals from the saddle or tee-wye branch to a terminal point in accordance with Details S-9 and S-10. All laterals shall be six-inch (6") diameter, unless otherwise noted.
- C. All laterals shall run straight and be laid on a minimum slope of two (2) percent. No lateral may be deeper than nine (9) feet at its free end, measured to the invert, unless permitted by the ENGINEER.
- D. CONTRACTOR shall construct all laterals to the property line and extend a maximum of one (1) foot beyond the property line. The free end of the lateral shall be a minimum of three (3) feet from the edge of curb or sidewalk. Rock in all lateral trenches must be removed to a point not less than one-foot (1') beyond the end of the pipe.
- E. Laterals shall be a maximum of 50-feet in length unless otherwise approved by the ENGINEER. Cleanout(s) must be installed at the right-of-way line, at every bend, and every 100-feet regardless of the length of lateral.

- F. Where the depth of the main pipeline exceeds ten (10) feet, construct laterals from the tee or tee-wye branch in accordance with Detail S-10 unless the elevation of the building to be served precludes this option. The determination as to the type of riser, slope, and depth of lateral pipe at the termination point will be made by the CONTRACTOR in the field.
- G. The free end of all laterals must be fitted with a vertical six-inch (6") tee. The horizontal branch shall be reduced to four-inches (4") and sealed with an approved watertight push-on type plug, braced to withstand pipeline test pressure thrust, at the termination of the lateral. The vertical branch of the tee shall be brought to grade with a vertical six-inch (6") stack and a recessed type clean out plug shall be installed.
- H. Lateral vents and cleanouts shall not be located within paved areas, and shall be a minimum of three-feet (3') from curbs and sidewalks. All lateral vent caps and cleanouts shall be at least six (6) inches above finished grade. A screw-on type clean out plug with recessed socket shall be provided at finished grade on all lateral clean outs. As a retrofit during construction, the ENGINEER may approve laterals which, due to unforeseen conditions, must be located within or near paved areas. Lateral clean outs within or less than three-feet (3') from any paved area or sidewalk shall be provided with a clean out protection sleeve consisting of a cast iron frame and cover as per Detail S-12.
- I. If water exists in the lateral trench, no lateral pipe may be placed until the water is removed.
- J. Laterals shall not connect to manholes unless approved by the ENGINEER.
- K. Sanitary laterals crossing water mains with less than 18" vertical clearance shall be concrete encased for a distance of ten (10) feet either side of the crossing.
- L. Unless otherwise approved by the ENGINEER, each lateral service for a non-residential use shall be provided with a manhole constructed in accordance with these Specifications to allow access for sampling individual sewage flows. A drop manhole shall not be used for this purpose. When not located within the public right-of-way, easements shall be provided to ensure that the sampling manhole may be accessed by AUTHORITY personnel at all times.

### **02610.3.05 BUILDING SEWER**

- A. Construct building sewer from lateral to building in accordance with edition of the International Plumbing Code adopted by the local Township or Borough.
- B. Pipe shall be embedded in coarse aggregate as specified in Section 02220 and as shown on Detail M-1.

### **02610.3.06 WATER SERVICE INSTALLATION (DOMESTIC AND FIRE)**

- A. Installation of service lines shall not be permitted until after the water main has satisfactorily passed tests for the lack of fecal coliforms and for leakage and hydrostatic pressure. Prior to these tests, corporation stops shall be inserted.

- B. All new water service connections shall be 3/4 diameter (minimum) unless otherwise determined by the AUTHORITY. Provide each water service connection with a corporation stop and curb stop as shown on Detail W-1 and specified in this Section. The service connection beyond the curb stop shall be the responsibility of the consumer.
- C. All existing water service connections requiring repair or replacement may be repaired or replaced using the existing diameter service pipe, provided that the use of the structure being served has not been changed. The minimum diameter service line for existing residential use shall be 3/4".
- D. The service line extension must be laid in a straight line at right angles to the street and at a depth necessary to secure proper alignment and avoid obstacles. Four feet (4') of cover shall be maintained for the service piping. Service pipe located within a road right-of-way shall be bedded and backfilled in accordance with Section 02200 of these Specifications.
- E. All service connection piping shall be installed in continuous runs from the corporation stop to the curb stop and from the curb stop to the ball valve located inside the structure. Connections in service piping longer than 100 feet shall be made using an additional curb stop and box assembly. Buried couplings shall be prohibited.
- F. As a general rule, all service lines shall be located at the mid-point between side lot lines. Curb boxes shall not be placed in sidewalks or driveways. Where curb boxes are located less than three feet (3') from any paved area or sidewalk, a clean-out protection sleeve consisting of a cast iron frame and cover as per Detail S-12 shall be provided.
- G. Service connections in ductile iron mains shall be made in accordance with the table and where service clamps are required they shall be Adams, Rockwell, or Mueller service clamps (double strap), or approved equal. Service clamps shall be bronze or galvanized malleable iron. Straps, nuts, and washers for service clamps shall be Type 304 stainless steel. Service clamps shall be required for taps in Class 52 ductile iron pipe. An engagement of three full threads is required on connections where no service clamps are used.

**Size of Tap**

<b>Pipe Diam.</b>	<b>3/4"</b>	<b>**1"</b>	<b>1-1/4"</b>	<b>1-1/2"</b>	<b>2"</b>	<b>2-1/2"</b>	<b>3"</b>	<b>3-1/2"</b>	<b>4"</b>
6"	None	S.S.	S.S.	S.S.	S.S.	D.S.	NTP	NTP	NTP
8"	None	S.S.	S.S.	S.S.	S.S.	D.S.	NTP	NTP	NTP
10"	None	None	S.S.	S.S.	S.S.	D.S.	D.S.	NTP	NTP
12"	None	None	None	None	S.S.	D.S.	D.S.	D.S.	D.S.

S.S.: Single Strap

D.S.: Double Strap

NTP: No Taps Permitted

None: No Service Clamp Required

\*\* = a 3/4 inch by 1 inch corporation stop may be used in lieu of a single strap.

- H. Water service saddles for C-900 water mains shall be of the single band (3¼" wide, minimum) style with the AWWA taper thread for insertion of the corporation stop. The saddle shall be sized and designed for use on PVC water main and be S70 style as manufactured by Ford Meter Box Company, or approved equal.

#### **02610.3.07 THRUST BLOCKS**

- A. Thrust blocks shall be provided by the CONTRACTOR where fittings are used to change the direction of pressure pipelines and must be formed against a solid trench wall which is excavated by hand so as not to damage the bearing surface. The thrust blocks must be constructed so the bearing surface is in direct line with the major force created by the pipe or fitting.
- B. Materials used for construction of concrete thrust blocks shall conform to Section 03302 of these Specifications. All pours shall be monolithic.
- C. Forms used by the CONTRACTOR must be adequately constructed and supported to prevent bulging of and/or deforming the concrete. Forms are to be coated with cup grease or an approved equal in order to facilitate removal. All forms must be removed by the CONTRACTOR after the concrete has sufficiently hardened.
- D. Water must be removed from all areas where concrete is to be poured.
- E. Backfilling over the concrete shall not be permitted until the concrete has sufficiently hardened. Concrete must be tuckered and worked in a manner that will cause the concrete to fill all voids under and around pipes. No coupling, joint, or nuts and bolts shall be covered with concrete.
- F. All thrust blocks, encasements and/or concrete anchors shall be constructed to the dimensions specified in the Standard Details section of these specifications. These items shall be required at the locations specified on the Drawings. The ENGINEER may add additional thrust blocks or anchors in the field if they are required.

#### **02610.3.08 CAST-IN-PLACE CONCRETE CONSTRUCTION**

- A. Conform to the applicable requirements of Section 03302.

#### **02610.3.09 CONCRETE ENCASEMENT**

- A. Provide concrete encasement for pipeline where indicated on the design plans, or as directed by the ENGINEER, and in accordance with Detail M-2.

#### **02610.3.10 STREAM CROSSINGS**

- A. Construct sanitary sewer stream crossings in accordance with Section 02170.

### **02610.3.11 HIGHWAY AND RAILROAD CROSSINGS**

- A. Install water and sanitary sewer lines crossing highways and railroads as shown on design plans. Comply with Railroad Company, Pennsylvania Department of Transportation, and Local Municipal Permits.
- B. Service lines traversing under existing roadways may be tunneled using approved methods. Tunneling with the use of pneumatic piercing tools shall be considered for installation of water services only. Where the tunneled or bored hole exceeds the nominal outside diameter of the service pipe, a carrier pipe sized to fit the existing bored hole shall be provided and the service connection shall be installed and supported within the carrier pipe.
- C. When casing pipe is required, comply with requirements of Section 02300.

### **02610.3.13 BRIDGE OR AERIAL CROSSING**

- A. For an above-the-ground water or sanitary sewer line attached to a bridge or other structural supports, furnish and install all supports, hangers and fastenings, insulation, heat tracing, and protection jacket as shown on the design plans.

### **02610.3.14 BACKFILLING TRENCHES**

- A. Backfill pipeline trenches only after examination of pipe laying by the ENGINEER.
- B. Backfill trenches as specified in Section 02220.

### **02610.3.15 TESTING**

- A. Piping shall be tested for leakage in accordance with Section 02650.
- B. PVC gravity sewers shall be tested for deflection in accordance with Section 02650.
- C. Gravity sewers shall receive a televised inspection in accordance with Section 02650.

**END OF SECTION**

**SECTION 02650**  
**WATER AND SANITARY SEWER SYSTEM TESTING**

**PART 1- GENERAL**

**02650.1.01 SUMMARY**

A. Section Includes:

1. Testing Water & Sanitary Force Mains:
  - a. Hydrostatic leakage test
  - b. Bacteriological test (water mains only)
2. Testing Gravity Sanitary Sewer Pipelines:
  - a. Low-pressure air test
3. Deflection Testing of Plastic Sewer Pipe
4. Testing of Manholes and Circular Concrete Chambers:
  - a. Vacuum Test
  - b. Exfiltration Test
5. Televised Inspection of Gravity Sewers

**02650.1.02 RELATED SECTIONS**

A. Related Work Specified Elsewhere:

1. Section 02610 – Utility Pipe and Fittings
2. Section 02605 – Manholes and Vaults

**02650.1.03 QUALITY ASSURANCE**

A. Test Acceptance:

1. No test will be accepted until the results are below the specified maximum limits.
2. CONTRACTOR shall, at own expense, determine and collect the causes, offset failure, and retest until successful test results are achieved.

#### **02650.1.04 SUBMITTALS**

- A. Testing procedures
- B. List of test equipment
- C. Testing sequence schedule
- D. Provisions for disposal of flushing and test water
- E. Certificate of test gauge calibration
- F. Deflection mandrel drawings and calculations

#### **02650.1.05 JOB CONDITIONS**

- A. Do not allow personnel in manholes during low-pressure air testing.
- B. Provide relief valves set at 10 psig to avoid accidentally over pressurizing gravity sanitary sewer line during low pressure air testing.
- C. Only AUTHORITY personnel or their designated representative shall operate any existing valves.
- D. ENGINEER shall be present during all testing. If the ENGINEER does not witness the testing, the test procedure must be repeated at the CONTRACTOR's expense.

### **PART 2 – PRODUCTS**

#### **02650.2.01 HYDROSTATIC TEST EQUIPMENT**

- A. Water pump
- B. Pressure hose
- C. Water meter
- D. Test connections
- E. Pressure gauge, calibrated to 0.1 lbs/sq. in.
- F. Pressure relief valve
- G. All other equipment and accessories as required

#### **02650.2.02 AIR TEST EQUIPMENT**

- A. Air compressor
- B. Air supply line
- C. Shut-off valve
- D. Pressure regulator
- E. Pressure relief valve
- F. Stop watch
- G. Plugs

- H. Pressure Gauge with minimum divisions of 0.1 lbs./sq. in., calibrated to 0.04 lbs./sq. in.
- I. All other equipment and accessories as required

#### **02650.2.03 DEFLECTION TEST EQUIPMENT**

- A. Go, No-Go mandrels
- B. Pull/retrieval rope
- C. All other equipment and accessories as required

#### **02650.2.04 VACUUM TEST EQUIPMENT**

- A. Test head with pressure and vacuum gauges and vacuum pump
- B. Source of compressed air
- C. Vacuum line
- D. Stop watch
- E. Plugs
- F. All other equipment and accessories as required

#### **02650.2.05 EXFILTRATION TEST EQUIPMENT**

- A. Means of water volume measurement
- B. All other equipment and accessories as required

#### **02650.2.06 BACTERIOLOGICAL TESTING**

It is highly recommended that the CONTRACTOR obtain the services of a PADEP certified laboratory to collect samples for bacteriological testing. If CONTRACTOR collects samples to deliver to laboratory, the collection procedure must be in accordance with AWWA C651 and Section 02650.3.06.

### **PART 3 – EXECUTION**

#### **02650.3.01 PRESSURE MAIN HYDROSTATIC TESTING**

- A. Test each newly laid pipeline, in accordance with AWWA C-600, including all water service connections, any valved section thereof, hydrostatically for a period of not less than 60 minutes at a minimum of 100 psi or 150% above the normal operating pressure (whichever is greater) based upon the elevation of the lowest point in the pipeline corrected to the elevation of the test gauge. The maximum test pressure shall be 175 psi.
- B. Test sections shall be limited to 1,000 linear feet in length. An intermediate test of the pipeline prior to tapping the main can be done by the CONTRACTOR at no additional cost to the AUTHORITY; however, all final testing is to be performed following the installation of all services to the right-of-way line.
- C. Where any section of a main is provided with concrete thrust blocking, the pressure test shall not be made until at least five (5) days has elapsed after the concrete thrust blocking was installed.

- D. The pressure shall be applied by means of a pump connected to the pipe in a manner satisfactory to the ENGINEER. CONTRACTOR shall provide all equipment necessary to perform the required testing. Slowly fill the section to be tested with potable quality water, expelling air from the pipeline at the high points if necessary. The CONTRACTOR shall be responsible for installation of corporation cocks at all high points. After all air is expelled, close air vents and corporation cocks and raise the pressure to the specified test pressure.
- E. Observe exposed joints, fittings, and valves under test. Remove and renew cracked pipe, joints, fittings, and valves showing visible leakage. Retest as required.
- F. The test pressure shall be maintained for a period of not less than one (1) hour. Should any pressure test disclose an inability to hold the test pressure, the CONTRACTOR shall locate and correct defects and retest to the satisfaction of the AUTHORITY.
- G. After any/all deficiencies are corrected, continue testing at the same pressure for an additional two-hours to determine the leakage rate. Maintain pressure within plus or minus 5.0 psig of test pressure. Leakage is defined as the quantity of water supplied to the pipeline necessary to maintain test pressure during the period of the test.
- H. Compute the maximum allowable leakage by the following formula:

$$L = \frac{SD\sqrt{P}}{133,200}$$

Where: L is the allowable leakage in gallons/hour  
 S is the length of the section tested in feet  
 D is the nominal diameter of the pipe in inches  
 P is the average test pressure in psig

If the line under test contains sections of various diameters, the allowable leakage shall be the sum of the computed leakage for each size.

- F. If the test of the pipe indicates leakage greater than that allowed, locate the source of leakage, make corrections and retest until leakage is within allowable limits. Correct visible leaks regardless of the amount of leakage.
- G. Only AUTHORITY personnel or their designated representative shall operate any existing valves. The ENGINEER shall be present during all testing. If the ENGINEER does not witness the testing, the test procedure must be repeated at the CONTRACTOR's expense.

**02650.3.02 GRAVITY SANITARY SEWER AIR TESTING**

- A. CONTRACTOR shall make tests as directed by the ENGINEER to ascertain if the pipe is properly aligned and the joints are tight. ENGINEER must witness all tests or the CONTRACTOR will need to retest in the presence of the ENGINEER at the sole cost of the CONTRACTOR.

- B. CONTRACTOR is responsible for providing a pressure gauge and a metering device (if required) for the test. CONTRACTOR shall also furnish a suitable pump and all other apparatus required, and shall pay all costs connected therewith. Defective work shall be repaired or replaced immediately at the CONTRACTOR 's expense.
- C. Test each newly installed section of gravity sewer line between manholes for leakage, including laterals, by using the Low Pressure Air Test : Time - Pressure Drop Method. All sewers shall be backfilled to a depth of not less than 2-feet above the sewer and all openings shall be carefully plugged and braced before start of the test. The testing procedure shall be in accordance with ASTM F1417. Although the following summarizes the required procedure, the CONTRACTOR shall be responsible for following the exact procedure as more fully described in ASTM F1417, including implementation of all safety precautions.
1. The air compressors to be used for the tests must be equipped to control the air entry rate and prevent the pressure from exceeding the specified pressure. The test shall be performed on pipe with a wet inside condition. All outlets in the section to be tested shall be fitted with air-tight plugs and braced to withstand the applied pressure.
  2. After the pipe has been wetted, the air shall be slowly admitted to the test section until a constant pressure of approximately 4.0 psig is reached. If groundwater is present, determine its elevation above the springline of the pipe by means of a piezometric tube. For every foot of groundwater above the springline of the pipe, increase the starting test pressure reading by 0.43 psig. Do not increase pressure above 9 psig. Allow temperature to stabilize for at least five (5) minutes. During this time, all plugs shall be checked for tightness with a soap solution. If leaks are found, the pressure will be released and the plugs tightened to stop the leakage. This procedure shall be repeated until all of the plugged openings are found to be tight. Adjust pressure to 3.5 psig greater than average groundwater back pressure and start test.
  3. Determine the test duration for a sewer section with a single pipe size from the following Table 1 or Table 2 (No allowance will be made for laterals):

**TABLE 1**  
**(Minimum Test Time for a 1.0 psig Pressure Drop for Ductile Iron Piping)**

Nominal Pipe Sizes, Inches	T (time) Minutes/100 Ft.
3-Inches	0.2
4-Inches	0.3
6-Inches	0.7
8-Inches	1.2
10-Inches	1.5
12-Inches	1.8
15-Inches	2.1
18-Inches	2.8

**TABLE 2**

**(Minimum Specified Time Required for a 1.0 psig Pressure Drop for Size and Length of PVC Pipe Indicated)**

Pipe Diameter, In.	Minimum Time, Minutes	Length For Minimum Time, ft	Time for Longer Length, sec.	Specification Time for Length (L) Shown, Minutes							
				100 ft	150 ft	200 ft	250 ft	300 ft	350 ft	400 ft	450 ft
4	3:46	597	0.380 L	3:46	3:46	3:46	3:46	3:46	3:46	3:46	--
6	5:40	398	0.854 L	5:40	5:40	5:40	5:40	5:40	5:40	5:42	--
8	7:34	298	1.520 L	7:34	7:34	7:34	7:34	7:36	8:52	10:08	--
10	9:26	239	2.374 L	9:26	9:26	9:26	9:53	11:52	13:51	15:49	--
12	11:20	199	3.418 L	11:20	11:20	11:24	14:15	17:05	19:56	22:47	--
15	14:10	159	5.342 L	14:10	14:10	17:48	22:15	26:42	31:09	35:36	40:04
18	17:00	133	7.692 L	17:00	19:13	25:38	32:03	38:27	44:52	51:16	57:41

4. Record the drop in pressure during the test period. If the air pressure has dropped more than 1.0 psig during the test period, the line is presumed to have failed. If the 1.0 psig air pressure drop has not occurred during the test period, the test shall be discontinued and the line will be accepted.
5. If the line fails, determine the source of the air leakage, make corrections and retest. CONTRACTOR has the option to test the section in incremental stages until the leaks are isolated. After the leaks are repaired, retest the entire section between manholes.
6. The air test shall not be accepted until all underground utilities (i.e., water, gas, electric, phone, cable) have been installed.
7. Prior to the connection to the system, all sewer mains shall be flushed by the use of high pressure water to remove debris. Collect and dispose of flushing water and debris but do not discharge directly to a stream or water course.

**02650.3.03 DEFLECTION TESTING OF PLASTIC SEWER PIPE**

A. Vertical Ring Deflection Test.

1. Perform vertical ring deflection testing on all portions of PVC sewer piping, in the presence of the ENGINEER after backfilling has been in place for at least 30 days but not longer than 12 months.
2. The maximum allowable deflection for installed plastic sewer pipe shall be limited to 5% of the original vertical internal diameter.
3. Perform deflection testing with a deflectometer, calibrated television, or a properly sized "Go, No-Go" mandrel. The mandrel(s) shall be constructed at CONTRACTOR's expense and subject to the approval of the ENGINEER. The CONTRACTOR must submit a notarized certificate to the ENGINEER from the mandrel manufacturer which states that the mandrel was constructed to allow for a maximum deflection of 5% in the PVC pipe.
4. Pipe exceeding the allowable deflection shall be located, excavated, replaced, and retested at the sole expense of CONTRACTOR.
5. Size mandrel according to Table 3 below.

**TABLE 3**

<u>Nominal Pipe Size</u>	<u>Outside Diameter of Mandrel</u>
4-Inches	3.68-Inches
6-Inches	5.45-Inches
8-Inches	7.28-Inches
10-Inches	9.08-Inches
12-Inches	10.79-Inches
15-Inches	13.20-Inches
18-Inches	16.13-Inches
21-Inches	19.01-Inches
24-Inches	21.36-Inches
27-Inches	24.06-Inches

- B. After successfully completing all required tests for alignment and leakage, all gravity sewer lines shall be televised in accordance with Section 02650.3.07.

**02650.3.04 VACUUM TESTING OF MANHOLES AND CONCRETE CHAMBERS**

- A. All manholes shall be vacuum tested using the following procedure:
  1. Before the test is performed, the manhole shall be fully completed including installation of grade rings and frame set to final grade. All pipe openings shall be sealed with plugs designed to provide a water tight seal and securely braced to prevent the plug from being drawn into the manhole. For manholes located in roadways, testing shall be performed after the binder course has been installed.
  2. The test shall be performed as per the manufacturer's recommendations along with the following requirements:
    - a. The test head shall be placed in the manhole frame in order to test the entire manhole structure including the grade adjustment ring joints.
    - b. The test head seal shall be inflated.
    - c. A vacuum of 10 inches of mercury shall be drawn after which the vacuum pump shall be shut off.
    - d. The time shall be measured for the vacuum to drop 1 inch of mercury.
  3. A successful test consists of an observed time period of at least the following duration:

**TABLE 4**  
**VACUUM TEST TABLE**

<u>Manhole Depth (ft.)</u>	<u>Manhole Diameter and Test Period (Sec.)</u>		
	<u>48" dia.</u>	<u>60" dia.</u>	<u>72" dia.</u>
0-10	60	90	120
10-20	90	120	150
20-30	120	150	180

- 4. ENGINEER shall be consulted with regard to an appropriate time for manholes exceeding a diameter of 72 inches.
- 5. If the manhole fails the test, necessary repairs shall be made to the satisfaction of the ENGINEER. Retesting shall be performed until a successful test is obtained.
- 6. Testing may be performed at the CONTRACTOR's option prior to backfilling; however, a successful test must be performed on the fully completed manhole after backfilling is completed and if in roadway, the base course has been installed.

- B. The testing equipment shall be an NPC Manhole Vacuum Tester as supplied by NPC Systems, Inc., Milford, NH, or approved equal.

### **02650.3.05 EXFILTRATION TESTING OF CONCRETE CHAMBERS**

- A. After the chamber has been properly cleaned and sealed, the chamber shall be completely filled with water. In order to make allowance for the amount of water which may be absorbed, the chamber to be tested shall be completely filled with water to the bottom of the cover seat for a period of one (1) hour prior to commencement of the “Exfiltration Test”.
- B. At the time of commencement of the “Exfiltration Test”, the chamber shall again be filled with water to the bottom of the cover seat and this water level shall be maintained for a minimum of one (1) hour, during which period an accurate record of the amount of water to be added by reason of leakage (exfiltration) will be kept.
- C. Each underground chamber being tested shall be considered “acceptable” when the total rate of exfiltration does not exceed a maximum allowable rate of 0.1 gallons per foot of diameter per vertical foot per hour. For underground chambers with non-circular cross-sections, the diameter used to calculate the maximum allowable rate of exfiltration shall be the equivalent diameter of a circle with the same cross-sectional area as the chamber. For simultaneous exfiltration testing of pump chamber (wet well) and valve chamber at a pump station, the maximum allowable rate of exfiltration shall be calculated for each chamber using 0.1 gallons per foot of diameter per vertical foot per hour. No additional allowance shall be included for underground piping between the chambers. If the total rate of exfiltration during the test does not exceed the maximum allowable rate of exfiltration of the pump chamber plus the valve chamber, then both chambers shall be considered “acceptable”.
- D. If the underground chamber does not satisfy these testing requirements, the source(s) of exfiltration causing the test failure must be located, repaired and retested until the testing requirements are satisfied.

### **02650.3.06 DISINFECTION OF WATER DISTRIBUTION SYSTEM**

- A. The CONTRACTOR shall take precautions during the installation of the pipeline to protect the pipe interiors, fittings and valves against contamination. Pipe delivered for construction shall be strung so as to minimize the entrance of foreign material. When pipe laying is not in progress as, for example, at the close of a day’s work, all openings in the lines shall be closed by watertight plugs. Joints of all pipe in trench shall be completed before work is stopped. If water accumulates in the trench, the plugs shall remain in place until the trench is dry.
- B. Each unit of completed water distribution system shall be thoroughly disinfected with chlorine before it is placed in operation. The amount of chlorine applied shall be such as to provide a dosage of not less than fifty (50) parts per million. The chlorinating materials shall be introduced to the water supply lines and/or distribution systems in a manner approved by the ENGINEER.
- C. All newly installed water lines shall be disinfected by the CONTRACTOR, as herein defined, before water is used for domestic consumption. One of the following two methods shall be employed:

1. **The Tablet Method:** by fastening the required number of calcium hypochlorite tablets to the inside of every length of pipe laid.

a. The Tablet Method is only applicable if the pipeline has been laid in a sanitary manner in the judgment of the ENGINEER. Otherwise, the line shall be flushed and the alternate method, described in the section below, shall be used.

b. The disinfection tablets of calcium hypochlorite having an available chlorine content of at least 70% by weight and sized to weigh 6 to 8 ounces per tablet. The tablets shall be fastened to the inside top of every length of pipe laid, starting with the first and progressing as each additional length is added. The number of tablets to be used per 20-foot section of pipe is tabulated below and appropriate adjustments are to be made if lengths other than 20-foot are used.

Pipe size, inches:	6	8	10	12	20	24
Tablets per 20-foot section:	3	4	5	8	22	32

c. When the installation has been completed, the main shall be filled with water at a velocity of less than 1-foot per second.

2. **The Feed Method:** by continually introducing a strong hypochlorite solution by means of a chemical solution or feed pump into metered fresh water introduced into the line.

a. The hypochlorite solution feed method of disinfection may be employed as an alternate to the tablet method, and must be employed if the sanitary condition of the line is suspect in the opinion of the ENGINEER. If the line is known to contain or has been in contact with dirty water, mud, or debris, it shall first be flushed at a flushing velocity of not less than 2.5 feet per second and for a time to pass on less than 3 volumes of line water.

b. The preferred point disinfection application is at the beginning of the valved section of the line where water is being introduced. Application may be made through a corporation stop. The water entering the new piping shall be metered and the proportional amount of disinfectant applied at a uniform rate while the process continues. Calcium hypochlorite may be used for disinfection and its application rate shall be 0.6 lbs. or 70% strength material per 1,000 gallons of water. If the application is being made to a line that has been flushed and which contains water, the application of the disinfecting solution shall be maintained until no less than 50 mg/L chlorine residual is found at the farthest end of the line.

D. Following a contact period of not less than twenty-four (24) hours, water samples from the extremities of the line should indicate a chlorine residual of 50 mg/L or more. If a residual less than that value is indicated, the disinfection procedure shall be repeated, otherwise, the heavily chlorinated water shall be flushed from the system with clean water until the residual chlorine content is not greater than the chlorine residual concentration present in the public water supply in that area. The CONTRACTOR is responsible for providing all equipment for flushing, including sufficient hoses and dechlorinating equipment. Only AUTHORITY personnel are permitted to operate valves on the existing public water supply.

- E. After disinfection, the CONTRACTOR shall determine the bacteriological quality of the line by laboratory testing at CONTRACTOR's expense. Samples shall be collected for bacteriological analysis on two (2) occasions at least 24 hours apart. Testing shall include field chlorine residual, total coliform analysis, and a Standard Heterotrophic Plate Count. The test results must be certified by a PADEP certified laboratory to assure that the water system is free from coliform bacteria contamination and the Standard Heterotrophic Plate Count is less than 500 CFU/mL.
- F. Upon satisfactory completion of the disinfection of the new water mains and acceptable test results, the AUTHORITY will flush the lines and place them in service. The CONTRACTOR shall provide all necessary equipment for flushing, including sufficient hoses and dechlorinating equipment.
- G. If any of the above-referenced testing or disinfection produces unsatisfactory results, the CONTRACTOR will be responsible to perform any required corrective work, at CONTRACTOR's sole cost, including rechlorinating and retesting the subject line until satisfactory results are obtained. The cost of additional water for retesting will be borne by the CONTRACTOR.
- H. If the CONTRACTOR does not employ the services of a certified laboratory for collection of the samples, the CONTRACTOR must collect the sample in sealed sterile bottles treated with sodium thiosulfate, in accordance with AWWA C651. In addition, a field chlorine residual test shall be taken at the time of sampling, the sample must be submitted to the laboratory below the maximum acceptable temperature, and a chain of custody form must be submitted with the testing results. Failure to meet any of these conditions will result in an unsatisfactory test. CONTRACTOR shall resample and retest at no cost to the AUTHORITY.

### **02650.3.07 TELEVISED INSPECTION OF GRAVITY SEWERS**

- A. Final acceptance of the sewer system will be contingent upon television inspection of all sewer mains, submission of documentation in the form of two (2) professionally prepared audio-videotapes and inspection logs to ENGINEER, with subsequent review and approval of tapes by ENGINEER and AUTHORITY.
- B. Any repairs which must be made as a result of this inspection shall be the DEVELOPER's responsibility and must be made prior to acceptance of dedication. The repaired section of pipe must be re-televised and work completed to the satisfaction of the ENGINEER.
- C. Prior to televising, CONTRACTOR shall clean the sewer line to permit passage of the camera. Any debris resulting from cleaning operations shall not be permitted to pass through the sewer system, but shall be flushed down to and removed from the downstream manhole of the sewer line. Water from the AUTHORITY water distribution system shall not be used for this purpose without prior authorization.
- D. Furnish all equipment, labor, materials and incidentals necessary for documenting the post-construction conditions of newly installed sanitary sewers by the use of closed circuit television. All work associated with televising of the sewer mains shall be conducted in the presence of the ENGINEER, including cleaning of the lines prior to televising.

- E. CONTRACTOR shall employ only competent personnel skilled in this type of work. CONTRACTOR shall have not less than two years experience with closed circuit television inspection and videotaping of sewer lines. ENGINEER may require evidence in the form of records from previous sewer inspections to substantiate any claims concerning the ability of the CONTRACTOR and their equipment to perform the Work as required.
- F. Any taped coverage not acceptable to the ENGINEER shall be refilmed.
- G. Two complete sets of project videos and reports shall be submitted to the ENGINEER for approval.
- H. Each video shall have an audio description of the location, size and type of material of the sewer being inspected along with all laterals, defects, cracks, leaks, or cross connections identified. Manhole descriptions and conditions shall also be recorded. The audio-videotape shall in no way relieve the CONTRACTOR from preparing and submitting the written report.
- I. A written report of the closed circuit television inspection shall be submitted, in duplicate, outlining the locations and the conditions found which are indicative of leaks, breaks, growths or incrustations, debris, serious misalignment or other adverse conditions. The report shall include, but not be limited to, the following:
  - 1. Location of beginning and terminal structure (station and offset shown on the Drawings).
  - 2. Pipeline material and size.
  - 3. Length of run and stations.
  - 4. Locations of all laterals, pipe breaks, cracks, infiltration, debris, etc. by station.
- J. The television camera used shall be one specifically designed and constructed for pipeline inspection and shall be capable of rotating 90 degrees in all directions. Lighting for the camera shall be suitable to allow a clear picture for the entire periphery of the pipe. The camera shall be operative in 100 percent humidity conditions, and the camera shall have a minimum of 600 line resolutions. Picture quality and definition shall be to the complete satisfaction of the ENGINEER.
- K. A self-propelled transport shall be employed when a skid mounted television camera cannot be used or winched through the sewer line. In no case will the television camera be pulled at a speed greater than 30 feet per minute. Radios, or other suitable means of communications, as required, shall be set up between the two manholes of the section being inspected.
- L. The cable or rod shall have a footage meter so that the location of the television camera and point of observation will be known at all times. The footage readings shall be automatically displayed on the video monitor in the television studio and shall be recorded on the permanent videotape log.
- M. To preclude the possibility of tampering or editing in any manner, all video recordings must, by electronic means, display continuously and simultaneously generated transparent digital information to include the name of the project, month, day, year, hour, minute and seconds of the day. This transparent alpha-numeric information will appear on the extreme upper-left hand third of the screen.
- N. The locations of each manhole, identification of street in which each sewer is located and direction which televising is being done shall be provided.

- O. Digital files shall be submitted on DVD format or thumb drive, and shall not have less than 180 lines of resolution. The audio-video recorder shall have sound dubbing facilities that will permit an audio track to be added to the recordings.
- P. Immediately repair or replace any defective work. Any pipe found broken or crushed shall be replaced by new pipe. Repaired or replaced pipe shall be retested as required by the ENGINEER. All sewer lines shall be re-televised after any repairs.

**END OF SECTION**

## **SECTION 02660**

### **WATER DISTRIBUTION SPECIALTIES**

#### **PART 1 – GENERAL**

##### **02660.1.01 SUMMARY**

Furnish and install all valves, valve boxes, and other piping specialties as specified herein and indicated on the Drawings to provide complete piping systems as intended.

##### **02660.1.02 RELATED INFORMATION**

###### **A. Related Sections:**

1. Section 02605 – Manholes
2. Section 02610 – Utility Pipe and Fittings
3. Section 02650 – Water and Sanitary Sewer System Testing

###### **B. Associated Construction Details:**

1. W-1 – Service Connection
2. W-3 – Fire Hydrant Connection
3. W-4 – Typical Gate Valve with Valve Box
4. W-5 – Air Release Valve
5. W-6 – Air Release Valve Manhole
6. W-7 – Residential Meter Installation

##### **02660.1.03 QUALITY ASSURANCE**

- A. Products shall be new and the latest standard of reputable manufacturers with replacement parts available. Products contaminated with gasoline, lubricating oil, liquid or gaseous fuels will be rejected.
- B. Potable water system products shall bear the seal of approval of the National Sanitation Foundation (NSF).

##### **02660.1.04 SUBMITTALS**

- A. Submit certified dimensional shop drawings and manufacturer's product data on valve operators including assembled weight, construction details, materials of components, and installation instructions.
- B. Submit manufacturer's maintenance instructions and complete parts lists.

## **02660.1.05 PRODUCT DELIVERY, STORAGE, AND HANDLING**

- A. Deliver valves and accessories to the job site in the manufacturer's boxes or crates. Mark each valve as to size, type, and installation location. Seal valve ends to prevent entry of foreign matter into valve body.
- B. Store valves and accessories in areas protected from weather, moisture, and possible damage. Do not store materials directly on ground.
- C. Handle valves and accessories to prevent damage to interior and exterior surfaces.

## **PART 2 – PRODUCTS**

### **02660.2.01 CORPORATION STOPS**

- A. Corporation stops shall be brass or red-brass alloy body in conformance with ASTM B62. Valve shall be ball type with T-head operator. Inlet shall be AWWA C800 thread, and outlet shall be compression connection. Corporation stops shall be Mueller Model No. B-25008N, or approved equal.
- B. Refer to Standard Detail W-1 for typical water service connection.

### **02660.2.02 CURB STOP AND CURB BOX**

- A. Provide quarter-turn brass curb stop with double O-rings, fluorocarbon coated spherical ball and stainless steel reinforced seat. Furnish with compression ends suitable for service piping. All curb stops shall be  $\frac{3}{4}$ " unless otherwise noted on the Drawings. Curb stops shall be Mueller Model No. B-25209N, or approved equal.
- B. Provide cast iron extension type curb box with arch pattern base, one-piece lid, foot piece, and stationary rod. Furnish curb boxes with bituminous coating (2 coats). Curb boxes shall be Model H-10314 with 89982 lids in unpaved areas and Model H-10334 with 89376 lids in roadways and other paved areas as manufactured by Mueller Company, or approved equal.
- C. Refer to Standard Detail W-2 for typical water service connection.

### **02660.2.03 RESILIENT SEATED GATE VALVES AND VALVE BOXES**

- A. Gate valves 12" and smaller shall be iron body, resilient seated, solid wedge gate valves conforming to AWWA C509 with an operating pressure of 250 psi. Valve shall have a non-rising stem and mechanical joint ends. Furnish valves with a 2" square operating nut. Valve box lid shall indicate the direction to turn valve operating nut in order to open. Valve shall be manufactured by Kennedy Valve, Mueller Company, or approved equal.

- B. Provide 5¼" diameter three-piece, cast iron, screw-type adjustable valve boxes with oval base, and one-inch riser ring for all buried gate valves. Valve boxes shall be of sufficient length to reach the surface of the ground, but not extend above the ground surface. The word "WATER" shall be cast in the top of the cover along with an arrow indicating the direction in which to turn to open the valve. Valve boxes shall be as manufactured by Tyler/Union Company 6860 Series, or approved equal.
- C. Precast concrete manholes required for gate valves 18" and larger shall be provided in accordance with Section 02605.
- D. Refer to Detail W-4 for typical installation of gate valves and valve boxes.

#### **02660.2.04 BLOW-OFFS**

- A. Refer to Detail W-9 for typical installation of a "blow-off" assembly.
- B. When a fire hydrant cannot be located at the dead-end of a water main, a blow-off shall be provided.

#### **02660.2.05 FIRE HYDRANTS**

- A. Fire hydrants must comply with current AWWA Standard C-502. The hydrant shall be a dry barrel, three-way type with minimum 150-psi service pressure and 300 psi test pressure. Hydrants shall be provided with a 6" mechanical joint inlet connection. Furnish each hydrant with a restrained, mechanical joint, resilient seated gate valve and valve box to grade.
- B. The hydrants shall be 5-1/4" size with one (1) 4-1/2" National Standard Thread (NST) pumper nozzle and two (2) 2-1/2" NST hose nozzles. All caps shall be provided with chains. The hydrant operating nut shall be 1-1/2" pentagonal shape and shall have an arrow to indicate the "open" direction. Hydrant's bury length shall be sufficient to allow hydrant break flange to extend no more than 2" above the ground line without the use of extensions when the connecting pipe has 4-foot of cover. Hydrant to be Mueller "Super Centurion" Model A-423, Kennedy "Guardian", Model K81, or approved equal.
- C. Fire hydrants shall be lubricated with Chevron H1 Lubricant FM grease (NSF61 certified, Food grade) or equal. Graphite or petroleum-based lubricants are not acceptable.
- D. Hydrants shall be painted with a primer coat of Duron Fast Dry Universal phenolic alkyd metal primer, color- off-white. Duron Item #33-042. Hydrants shall receive a finish coat of silicone alkyd enamel, with silver barrels and red bonnets, unless AUTHORITY indicates a different color scheme. Paints shall be as manufactured by Duron Paints, or approved equal.
- E. Hydrants shall be installed complete with marker poles and reflective bands. Hydrant marker poles shall be 5' Hydrant Marker Model #HYDRNT-C, as manufactured by BARCO Products, 11 N. Batavia Avenue, Batavia Illinois. Reflective Bands shall be Model #BSH-1.7528DG-B, as manufactured by Lordon, Inc., distributed by Letterco Inc., 1069 County Line Road, Souderton, PA 18964.
- F. Refer to Detail W-3 for typical installation of fire hydrants.

### **02660.2.06 FREEZELESS YARD HYDRANT**

Furnish and install a Freezeless Yard Hydrant where shown on the Drawings. Hydrant to have 1" N.P.T. inlet with galvanized steel pipe casing. Brass nozzle to have 1" male threaded end. Drain hole to be 1/8" tapped N.P.T. Yard hydrant excavation shall have filter fabric installed before No. 2B stone is placed. Freezeless IOWA Yard Hydrant shall be as manufactured by Woodford Manufacturing Company, or approved equal.

### **02660.2.07 TAPPING SLEEVES AND VALVES**

- A. Provide mechanical joint Type H-615 tapping sleeve as manufactured by Mueller Company, or approved equal. The type of pipe and actual outside diameter of the main should be confirmed by the CONTRACTOR before placement of order for the sleeve. Furnish resilient seated gate valve with flange inlet and mechanical joint outlet.
- B. Where a tapping sleeve and valve are not feasible, CONTRACTOR shall consult with the AUTHORITY to cut in a tee and valve. The CONTRACTOR shall schedule all work related to connections to the existing system, and provide increased work forces and off-hours work as necessary so as to minimize the shut-down time and inconvenience to present consumers. Approval of the proposed shutdown and tie-in schedule, procedures, and material must be obtained from the AUTHORITY or ENGINEER.

### **02660.2.08 AIR RELEASE VALVE**

- A. Air release valve shall close drop-tight and incorporate a renewable seat. All internal metal parts shall be of stainless steel. Valve body and cover shall be of cast iron conforming to ASTM A126, Class B and for working pressures up to 200 psig. Valve interiors and exteriors shall be coated with an NSF/ANSI 61 certified fusion bonded epoxy in accordance with AWWA C550. Valve size shall be 3/4" N.P.T. and be provided with an Inflow Preventer on the outlet. Provide 3/4" isolation ball valve with a working pressure of 200 psi, and screw ends. Air release valve shall be Val-Matic Model 22, DeZurik/APCO, or approved equal.
- B. Air release valve shall be installed in a manhole constructed in accordance with Section 02605 and Standard Detail W-6.
- C. In certain cases, ENGINEER may require the use of a combination air/vacuum valve, by Val-Matic, Apco or approved equal.

### **02660.2.09 BACKFLOW PREVENTERS**

- A. Backflow preventers are required on all water services. For residential water services with interior meter location, provide double check valve assembly backflow preventers on the domestic and fire service supply lines in accordance with Standard Details W-7 and W-8, as applicable. Backflow preventers shall be Ford HHC (dual check), or approved equal.

- B. A backflow preventer shall be installed on a water supply pipeline connecting to the AUTHORITY's main used for commercial fire protection. Unless otherwise approved by the AUTHORITY, the pipeline and appurtenances shall be used exclusively for fire protection. The backflow preventer assembly shall be a reduced pressure type, Watts Series 909, as approved by the AUTHORITY and local Fire Marshal. A Sensus Fireline Meter Assembly with strainer and detector check valve, or approved equal, shall be installed upstream of the backflow preventer.
  - 1. Note that Watts Series 909 has an atmospheric vent, so a pipe should be installed to direct the vented liquid to an acceptable drain.
- C. For commercial fire protection, the size of the pipeline, detector check valve and the backflow preventer shall be designed by MEP and fire protection engineering company and approved by the AUTHORITY and local Fire Marshal. Submit copies of plans of the private fire protection system for approval.
- D. When the length of fire service main to a building is greater than 25 feet, and when approved by the AUTHORITY, the domestic service line for that building shall be connected to the fire service line immediately before the backflow preventer to eliminate the "dead spot" of water in the service main. This connection shall be approved by the AUTHORITY.
- E. The AUTHORITY reserves the right to require the installation of reduced pressure backflow preventers for applications where a direct cross-connection exists between potable water and non-potable water or a back siphon condition exists.

#### **02260.2.10 PRESSURE REDUCING VALVES**

- A. A pressure reducing valve shall be installed on the house side of the meter on all water services receiving system pressure of 65 psi or greater. Pressure reducing valve shall be Watts UB5, or approved equal. Pressure reducing valve for new residential connections shall be installed as shown on Standard Detail W-7.
- B. When required by the AUTHORITY, a pressure-reducing valve shall be installed on new water main construction to limit downstream system pressures to a desirable level. Pressure reducing valves installed on mains shall be Golden Anderson Fig. 4500-D, or approved equal.

#### **02660.2.11 WATER METER YOKE FOR RESIDENTIAL SERVICE**

- A. All meter setting equipment must be suitable for use with one-half (1/2) inch through one (1) inch copper pipe, and one-half (1/2) inch through one and one-half (1½) inch iron pipe, by interchanging pack joint assemblies (see Standard Detail W-11).
- B. All meter setting bodies shall consist of bent copper tubing with spun flanges and nuts connected to a cast bronze fitting in such a manner as to make the unit rigid and receive the water meter. Meter setter shall be Ford Kornerhorn or approved equal.
- C. Water meter shall be provided and installed by the AUTHORITY.
- D. Contact AUTHORITY for approval of meter yoke for larger meter sizes.

### **02260.2.12 METER**

All water meters shall be located inside the building unless otherwise directed by the AUTHORITY. All water meters shall be manufactured in accordance with AWWA Standard C-700, the latest revision thereof (see Standard Detail W-7). Water meters shall be manufactured by Neptune's latest technology. Meters to be ordered through OWNER and paid by the DEVELOPER.

### **02660.2.13 OUTSIDE METER PIT**

- A. Meter pit cover shall be a Ford Meter Box Co., Type W32-T double lid cover. Cover to have lifter worm lock. Provide foam insulating disc inside cover.
- B. Water meter shall be mounted in copper meter yoke, Mueller B-24701-6A, or Ford VBCHC72, with integral angle ball valve and ASSE 1024 dual check valve.
- C. Water meter to be supplied and installed by the AUTHORITY.
- D. Water meter pits to be PVC, as manufactured by Mueller, and sized to match the service diameter.

## **PART 3 – EXECUTION**

### **02660.3.01 GENERAL**

Inspect joint surfaces for structural soundness and thoroughly clean before installation. Install valves and accessories in accordance with manufacturer's instructions. Check and adjust valves and accessories for smooth operation.

### **02660.3.02 SETTING HYDRANTS, VALVES, AND VALVE BOXES**

- A. All gate valves shall be set with the stems vertically above the centerline of the pipe. Special care shall be taken to avoid closing valves with sand, stones, or other substances lodged in the valve seat. Hydrants, valves, and valve boxes, shall be set plumb, with valve boxes placed directly over the valves. After being correctly positioned at street grade, stone fill shall be carefully compacted around the valve box for a distance of four (4) feet on all sides.
- B. Each hydrant shall be placed upon a solid cement block not less than four (4) inches thick and fifteen (15) inches square, or as directed. The back side of the hydrant opposite the pipe connection shall be firmly wedged against the vertical face of the trench with a thrust block. Additionally, the hydrant and hydrant valve shall be rodded from the flange of the hydrant through the valve to the flange of the hydrant tee. This shall be accomplished by the use of bridle rods and rod collars which shall not be less than 3/4" stock and shall be thoroughly protected by painting with two (2) coats of bituminous paint.

- C. Around the base of each hydrant shall be placed not less than 1 cubic yard of 2B crushed stone to ensure the complete drainage of the hydrant when closed. All backfill around hydrants shall be in 4" layers or less and shall be thoroughly compacted to the surface of the ground. Before installing any hydrant or valve, care shall be taken to see that all foreign matter and material is removed from the interior of the barrel. The hydrant and valve shall be opened and closed to see that all parts are in working order and condition. Set hydrant so that ground bead is at or above finished grade, and safety flange is not less than 2" or more than 6" above finished grade. Hydrant shall be located 2 feet behind curb, or as directed by AUTHORITY.
  
- D. CONTRACTOR, at the AUTHORITY's direction, shall perform flow tests on selected fire hydrants to determine actual static pressures and flow rates. CONTRACTOR shall provide all equipment and personnel to perform these tests in the presence of the ENGINEER.

**END OF SECTION**

**SECTION 02735  
LOW PRESSURE SEWER SYSTEMS**

**PART 1 - GENERAL**

**02735.1.01 DESCRIPTION**

Furnish and install all piping, valves, valve chambers, grinder pump systems, and other piping specialties as specified herein and indicated on the Drawings to provide complete Low Pressure Sewer System (LPSS) as intended.

**02735.1.02 RELATED INFORMATION**

A. Related Sections:

1. Section 02605 – Manholes and Vaults
2. Section 02610 – Utility Piping and Valves
3. Section 02650 – Water and Sanitary Sewer System Testing

B. Associated Construction Details:

1. S-22 - Low Pressure Sewer Lateral Connection with Check Valve
2. S-23 - Low Pressure Sewer Connection (Residential Force Main to Gravity Lateral Connection)
3. S-24 - Low Pressure Sewer Terminal Cleanout
4. S-25 - Low Pressure Sewer In-Line Cleanout
5. S-26 - Low Pressure Sewer Drop Connection in Existing Manhole

**02735.1.03 QUALITY ASSURANCE**

A. Low Pressure Sewers shall only be used when there is no reasonable means of providing gravity sewer service to a property.

B. Products shall be new and the latest standard of reputable manufacturers with replacement parts available. Products contaminated with gasoline, lubricating oil, liquid or gaseous fuels will be rejected.

C. Reference Standards:

1. ASTM A312 Standard Specification for Seamless and Welded Austenitic Stainless Steel Pipes
2. ASTM B62 Standard Specification for Composition Bronze or Ounce Metal Castings

3. ASTM D1784 Standard Specification for Rigid Polyvinyl Chloride (PVC) Compounds and Chlorinated Polyvinyl Chloride (CPVC) Compounds
4. ASTM D1785 Standard Specification for Polyvinyl Chloride (PVC) Plastic Pipe, Schedules 40, 80, and 120
5. ASTM D2241 Standard Specification for Polyvinyl Chloride (PVC) Pressure Rated Pipe (SDR) Series
6. ASTM D2447 Standard Specification for Polyethylene (PE) Plastic Pipe, Schedules 40 and 80, Based on Outside Diameter
7. ASTM D2464 Standard Specification for Threaded Polyvinyl Chloride (PVC) Plastic Pipe Fittings, Schedule 80
8. ASTM D2466 Standard Specification for Polyvinyl Chloride (PVC) Plastic Pipe Fittings, Schedule 40
9. ASTM D2467 Standard Specification for Polyvinyl Chloride (PVC) Plastic Pipe Fittings, Schedule 80
10. ASTM D2672 Standard Specification for Joints for IPS PVC Pipe Using Solvent Cement
11. ASTM D2774 Standard Practice for Underground Installation of Thermoplastic Pressure Piping
12. ASTM D2855 Standard Practice for Making Solvent-Cemented Joints for Polyvinyl Chloride (PVC) Pipe and Fittings
13. ASTM D3035 Standard Specification for Polyethylene (PE) Plastic Pipe (DR-PR) Based on Controlled Outside Diameter
14. ASTM D3139 Standard Specification for Joints for Plastic Pressure Pipes Using Flexible Elastomeric Seals
15. ASTM D3261 Standard Specification for Butt Heat Fusion Polyethylene (PE) Plastic Fittings for Polyethylene (PE) Plastic Pipe and Tubing.
16. ASTM D3350 Standard Specification for Polyethylene Plastic Pipes and Fittings Material
17. ASTM D3753 Standard Specification for Glass-Fiber – Reinforce Polyester Manholes and Wetwells

18. ASTM F437 Standard Specification for Threaded Chlorinated Polyvinyl Chloride (CPVC) Plastic Pipe Fittings, Schedule 80
19. ASTM F438 Standard Specification for Socket-Type Chlorinated Polyvinyl Chloride (CPVC) Plastic Pipe Fittings, Schedule 40.
20. ASTM F477 Specification for Elastomeric Seals (Gaskets) for Joining Plastic Pipe
21. ASTM F714 Standard Specification for Polyethylene (PE) Plastic Pipe (SDR-PR) Based on Outside Diameter
22. ASTM F1055 Standard Specification for Electrofusion Type Polyethylene Fittings for Outside Diameter Controlled Polyethylene Pipe and Tubing
23. ASTM F2164 Standard Practice for Field Leak Testing of Polyethylene (PE) Pressure Piping Systems Using Hydrostatic Test Pressure.
24. NSF Std. 46 Evaluation of Components and Devices Used in Wastewater Treatment Systems.
25. U.L. Std. 778 Standard of Safety of Motor-Operated Water Pumps
26. U.L. Std. 508 Standard of Safety of Industrial Control Equipment
27. CSA Std.108 Liquid Pumps

#### **02735.1.04 SUBMITTALS**

- A. Submit certified dimensional shop drawings and manufacturer's product data for the pump station, piping, valves, and valve operators including assembled weight, construction details, materials of components, and installation instructions.
- B. Submit manufacturer's maintenance instructions and complete parts lists.
- C. Specifications and Drawings shall be submitted to the ENGINEER for review, which shall contain at a minimum, the following information:
  1. Calculations showing projected flow and total dynamic head.
  2. Pump selection including pump motor size, basin size, electrical power, and location of system with respect to collection system.
  3. Calculations on basin storage capacity in the event of a power failure and normal pump cycling times.
  4. Drawings and specifications from the manufacturer showing the above information.

5. If multiple grinder pump stations are to be sharing common force mains, provide manufacturer's calculations based on Rational Method or other approved method (in Excel format), showing the flows in all branches and listing all assumptions and determinations.

#### **02735.1.05 PRODUCT DELIVERY, STORAGE AND HANDLING**

- A. Deliver valves, pumps, basins, and accessories to the job site in the manufacturer's boxes or crates. Mark each valve as to size, type, and installation location. Seal valve ends to prevent entry of foreign matter into valve body.
- B. Store valves and accessories in areas protected from weather, moisture, and possible damage. Do not store materials directly on ground.
- C. Handle valves and accessories to prevent damage to interior and exterior surfaces.

### **PART 2 - PRODUCTS**

#### **02735.2.01 PIPING**

In accordance with Section 02610.

#### **02735.2.02 AIR VALVE CHAMBERS**

Provide precast circular concrete manholes with flat slab tops and as specified in Section 02605.

#### **02735.2.03 SEWAGE COMBINATION AIR VALVES**

- A. Provide in accordance with Section 02770.

#### **02735.2.04 CHECK VALVES**

On all individual grinder pump force mains, provide combination curb stop and check valve at or near right-of-way line for redundant backflow protection. See Paragraph 02735.2.05 for requirements.

#### **02735.2.05 CURB STOP AND CURB BOX**

- A. Curb Stop/Swing Check Valve Combination Assembly: The Curb Stop/Swing Check Assembly shall contain a Curb Stop as described under heading "Curb Stop" and a Swing Check as described under heading "Swing Check". The Curb Stop and Swing check shall be joined with a section of 6" through 12" Polyethylene pipe of the same size as the lateral specified tubing. The assembly shall be shipped as a completed unit with ends to accommodate the specified service tubing. To be manufactured by Lateral Connection, or approved equal.

www.lateralconnection.com  
#101 - 26712 Gloucester Way • Langley, BC • V4W 3V6  
t. 604-856-7253 / 855-292-8240 • f. 604-381-2148  
sales@lateralconnection.com

1. Thermoplastic curb stop valves for forced sewer applications shall be manufactured from polypropylene compound and be ISO 9002 certified. All valves shall be rated for 200 PSI Service. Each valve shall have an operating handle profiled for manual or service key operation. The handle shall have a built-in safety feature that disengages and ratchets in either direction when operating torque exceeds 20 ft. lbs. Valves shall have end connections to accommodate the specified service tubing.
2. Swing check valves for forced sewer services shall be manufactured from Ultra High Impact PVC Material. All valves shall be rated for 125 PSI back pressure. 1-1/4" valves shall have end connections to accommodate the specified service tubing. 1-1/2" and 2" valves shall have female NPT ends with injection molded compression by male NPT pressure fittings installed to accommodate the specified service tubing

- B. Curb Box: Cast iron with stationary rod and foot piece, lid with brass plug and inscription "SEWER"; manufactured by Mueller Company (Cat. Nos. H-10336 (box), H-10393 (foot piece), 89981 (lid), or approved equal. Provide with arched enlarged base and 18" long extension rod.

#### **02735.2.06 THERMOPLASTIC BALL VALVES**

Provide true union, fully ported, ball valves with two-way blocking capability. Valves shall have a pressure rating of 230 psi for sizes 3 inches or less in diameter and 150 psi for 4 inches and above, at 70°F. Valves shall be provided with Teflon seats with elastomeric backing cushions of the same material as the valve seals. Stem shall have double O-Ring design and be of blowout-proof design.

#### **02735.2.07 STAINLESS STEEL BALL VALVES**

These valves shall be used in Air Valve Chambers, to match with Stainless Steel Piping. Valves shall be fully ported with type 316 stainless steel ball, retainer gland, and stem; 18-8 stainless steel lever, ASTM A 351 CF8M body; and reinforced TFE seat and stuffing box ring. 2000-psi working pressure. Valves shall be threaded to match stainless steel pipe.

#### **02735.2.08 RESIDENTIAL GRINDER PUMP STATIONS**

For the purpose of uniformity within the AUTHORITY Service Area, all residential grinder pump stations shall be subject to the minimum criteria established in the following specifications, which describe a Barnes Eco TRAN Simplex Grinder Pump Station with either a Model OGVF or OGP 2 hp centrifugal grinder pump. E/One Corporation is considered an approved equal. Other systems will only be approved if the system manufacturer demonstrates to the satisfaction of the AUTHORITY ENGINEER that the equipment proposed meets or exceeds the minimum quality, performance, safety and design criteria established in these specifications, with the exception of proprietary materials and equipment.

- A. All manufacturers of grinder pump stations must have been in the business of manufacturing complete grinder pump stations for a minimum of ten years. Manufacturer Representatives, Distributors, or Packagers will not be considered as manufacturers.
- B. Grinder Pump Station shall be completely assembled, factory wired and tested. Pump Station shall be U.L. listed.

C. Station Configuration

Basins shall be supplied in a wet well configuration. The wet well for individual residential applications must have storage volumes according to the following table:

<u>Volumetric Range</u>	<u>Capacity</u>
Volume at “Off”	11 Gallons Maximum
“Off” to “On” Volume	20 Gallons Minimum
“On” to “Alarm” Volume	18 Gallons Minimum
“Alarm” to “Inlet” Volume	15 Gallons Minimum

D. Factory Wiring

All wiring in the grinder station shall be installed and functionally tested prior to shipment from the factory. All electrical cables penetrating or passing through the silhouette of the pump station must be guaranteed to be water-tight by the manufacturer and must be installed at the factory prior to shipment. The pump power cable shall be connected to the direct burial cable with a waterproof electrical connector certified to NEC and IEC IP68 ratings.

E. Check Valve

The pump discharge shall be equipped with a factory-installed gravity-operated flapper-type check valve. The valve will provide a fully ported passageway when open and shall introduce a friction loss of less than six inches of water at maximum rated flow. Working parts shall be made of 300 series stainless steel and non-wicking fabric reinforced neoprene flap to ensure corrosion resistance, repeatability and dimensional stability. The valve body shall be powder-coated cast iron for corrosion resistance.

F. Level Detection

Level detection for controlling pump and alarm operation shall be accomplished by use of a detection device specifically designed for use in a sewage grinder station. Switches utilized in the system shall be hermetically sealed in a submersible, watertight protective housing, with an integral pressure-compensating diaphragm. The level detection device shall consist of two independent switches, one for each function (High Water Alarm and On/Off actuation). In addition, the device shall include a solid-state relay for directly controlling the pump motor. The level detection device shall include an automatically resetting, heat sensing thermal switch that interrupts current flow if excessive liquid temperature is detected. This thermal switch shall be part of the U.L. listing. The level control shall be serviceable without confined space entry as defined by OSHA.

G. Shut-Off Valve

The pump discharge shall be equipped with a factory-installed manual ball valve. Ball valves shall be fully ported, constructed of bronze with stainless steel ball, stainless steel stem and hardware, and Teflon seats, with a minimum rated pressure of 150 PSI. All valves shall be operable from ground level with a color-coded actuation cord tagged green to open, red to close.

Shut-off valve must be replaceable from above without confined space entry.

#### H. Anti-Siphon Valve

The pump shall be constructed for a positively primed, flooded suction. As added assurance that the pump cannot lose prime, even under negative head conditions in the discharge piping, the pump must include provision for a flapper-style valve in the discharge line prior to the check valve. The design shall provide for a maximum bypass, under normal operating conditions, of no more than 1GPM.

#### I. Basin Construction and Assembly

1. The basin shall be injection-molded engineered polypropylene copolymer thermoplastic with a corrugated high-density polyethylene riser. The riser shall be sealed to the basin and cover adapter with a high surface contact engineered gasket designed specifically for use with corrugated piping. The basin shall be provided with three blanked-off inlet positions, 90 degrees apart, for field selection to simplify installation. Only one port is to be opened in the field, with connection to the 4" inlet piping using a flexible "Fernco" type fitting supplied by manufacturer. The basin must be designed to withstand wall collapse or buckling based on a hydrostatic pressure of 62.4 pounds per square foot, a saturated soil weight of 135 pounds per cubic foot, and a soil modulus of 700 pounds per square foot. The basin must be constructed to withstand or exceed 200% of the assumed loading at any depth.
2. All piping within the basin silhouette shall be at a level in the station that is lower than the frost depth; i.e. no higher than the inlet. The basin package shall be furnished with a factory pre-wired waterproof power connector.
3. Cover shall be molded LLD polyethylene. Cover shall attach to riser with quarter-turn to fasten in place, with hasps and safety padlock provided by the manufacturer.
4. All internal discharge pipe shall be constructed of bronze and terminate outside the bulkhead with a stainless steel flexible fitting with female NPT connection. The manufacturer shall guarantee all bulkhead penetrations be watertight.
5. Each basin shall be equipped with an injection-molded engineered polypropylene thermoplastic POD to locate and position the grinder pump and level control device. Pump and control to be removable without requiring the loosening of fasteners. POD to provide automatic alignment and connection of pump to discharge piping and level control with no additional adjustment required. A 1/2" diameter knotted polypropylene rope harness with a minimum breaking strength of 3750 pounds shall be attached to the pump at two locations for removal and installation purposes. The POD shall be designed to facilitate removal of the shut-off valve without basin entry in the event maintenance is required.

## J. Pumps

1. A submersible centrifugal grinder pump shall be furnished, designed to reduce all materials found in normal domestic sewage into a finely ground slurry. The pump is to be capable of pumping the resultant slurry through small diameter piping to a gravity interceptor or treatment facility at the flows and heads specified. The pump is to be capable of continuously operating with a maximum liquid temperature of 104°F (40°C) and shall be capable of running dry for extended periods of time.
2. Pump shall be suitable for long-term submergence in sewage. Grinder pump shall be U.L. listed to Standard 778 and CSA listed to Standard 108, as well as to NSF/ANSI 46.
3. In order to ensure proper operation under all conditions, pump must provide, without overheating in continuous operation, the maximum head condition required by the system. Pump must also be capable of operating at zero or negative heads without damage to the pump.
4. Pump shall be Barnes Model OGVF or OGP, 2 hp, 3450 rpm, 240 Volt Single Phase, or approved equal. The exact model selected for each application shall depend upon projected flow and total dynamic head on the system and shall be subject to the approval of the ENGINEER. If the above model does not meet the application, the ENGINEER shall be notified and alternate models of equal quality shall be presented to the ENGINEER for approval.

## K. Alarm Panel

1. A wall mounted alarm panel shall be supplied with each station. Alarm panel to be U.L. listed to meet Standard 508. Panel to be constructed with a NEMA 4X fiberglass enclosure utilizing stainless steel hardware and be provided with hasps for locking.
2. The alarm panel shall be equipped with a circuit breaker, ground lug, and relays in order to facilitate pump operation and high-level alarm indication. Terminal strips to facilitate both input power and connection to the grinder station shall be provided.
3. Each alarm panel shall include both visual and audible alarm indications. The alarm circuit shall be separately fused from the motor control circuit. The visual indication shall be provided by a red fluted lens mounted to the top of the enclosure in such a manner as to maintain rainproof integrity. A 90 dB audible device shall also be provided with a NEMA 4X silence button mounted on the exterior of the enclosure. The visual alarm will remain on as long as the high water condition exists in the basin; both visual and audible alarms to automatically reset when the high water condition subsides.

### **02735.2.09 COMMERCIAL GRINDER PUMP STATIONS**

For the purpose of uniformity within the AUTHORITY Service Area, grinder pump stations shall be subject to the minimum criteria established in the following specifications, which describe a Barnes Duplex EasyELECTRIC™ Grinder Pump Station with FLOATTREE Level Detection System. Other systems will only be approved if the system manufacturer demonstrates to the satisfaction of the AUTHORITY and ENGINEER that the equipment proposed meets or exceeds the minimum quality,

performance, safety and design criteria established in these specifications, with the exception of proprietary materials and equipment.

- A. All manufacturers of duplex grinder pump stations must have been in the business of manufacturing complete grinder pump stations for a minimum of ten years. Manufacturer Representatives, Distributors or Packagers will not be considered as manufacturers.
- B. Grinder Pump Station shall be completely assembled, factory wired and tested. Pump Station shall be U.L. listed.
- C. Station Configuration

For the purpose of uniformity within the AUTHORITY Service Area, basins shall be supplied in a wet well configuration. Wet well must have minimum storage volumes above alarm level according to the following table:

<b><u>Overall Station Height</u></b>	<b><u>Minimum Reserve Storage Above Alarm Level</u></b>
48" (1.2 Meters)	35.7 gallons (135 Liters)
60" (1.5 Meters)	59.2 gallons (224 Liters)
72" (1.8 Meters)	82.7 gallons (313 Liters)
84" (2.1 Meters)	106.2 gallons (402 Liters)
96" (2.4 Meters)	129.7 gallons (491 Liters)
108" (2.7 Meters)	153.2 gallons (580 Liters)
120" (3.0 Meters)	176.7 gallons (669 Liters)

- D. Factory Wiring

All wiring in the grinder pump station shall be installed and functionally tested prior to shipment from the factory. All wire connections inside the basin wet well must be completed during factory assembly and 100% functionally tested prior to shipment. This includes all control panel connections. All electrical wires penetrating or passing through the silhouette of the pump station must be guaranteed to be water tight by the manufacturer and must be installed at the factory prior to shipment. No junctions, plugs, electrical quick disconnects (EQD's), etc. will be allowed between the pump motor housing and the junction box, nor junction box and control panel. Direct burial electrical cable must be factory installed in the station and arrive at the job site with a minimum length necessary to run the entire distance external to the pump station ready to unroll and connect to the power source and control panel.

- E. Check Valve

The stainless steel pump discharge piping shall be equipped with factory installed gravity operated flapper-type check valve. This valve will provide a full ported passageway when open, and shall introduce a friction loss of less than six inches of water at maximum rated flow. Working parts will be made of 300 series stainless steel and non-wicking fabric reinforced neoprene flap to ensure corrosion resistance, repeatability, and dimensional stability. The valve body shall be powder-coated cast iron for corrosion resistance.

F. Level Detection

Level detection for controlling pump and alarm operation shall be accomplished by use of a detection mechanism specifically designed for use in a sewage grinder pump basin and shall be removable without the need to remove the pump. Switches utilized in the system shall be hermetically sealed in a submersible, watertight protective casing. Level detection mechanism shall be a Float Tree type designed to provide switch protection from solids, greases, oils, and fats. Level detection mechanism shall not require any regular, preventive maintenance. The level detection mechanism shall consist of four switches, one for each function (HIGH WATER ALARM, ON, LAG ON, and OFF functions). Switch assembly shall utilize an 18-8 cable with color coded leads. Switch assembly shall be 100% tested prior to shipment. The level controls shall be serviceable without the need for a confined space entry as defined by OSHA or the need to remove the pump. Conventional suspending of mercury floats, mechanical, or swing arm floats for HIGH WATER ALARM, ON, LAG ON, and OFF functions will not be acceptable.

G. Shut-Off Valve

The station discharge shall be equipped with a factory installed, true union, manual ball valve. Ball valves shall be full ported, constructed of PVC, with a minimum rated pressure of 150 PSI. All valves shall be operable from ground level. Shut off valve must be replaceable without excavating basin exterior. Duplex station shall utilize two shut off valves, each equal to the size of the pump discharge.

H. Anti-Siphon Capability

The pump shall be constructed with a positively primed, flooded suction configuration. As added assurance that the pump cannot lose prime even under negative pressure conditions in the discharge piping system, the discharge piping system must include an anti-siphon capability. The design shall provide for a maximum bypass, under normal operating conditions, of no more than one (1) GPM.

I. Basin Construction and Assembly

1. The basin shall be fiberglass reinforced polyester resin with a 3" ballast support flange. Dimensions shall be as required by design conditions and as approved by the AUTHORITY, but in no case less than 36" diameter by 96" depth. The basin shall be furnished with one flexible inlet flange (shipped loose to facilitate field location) to accept a 6" schedule 40 PVC pipe. Inlet location should be adjustable to accommodate varying building sewer alignments. The basin FRP wall laminate thickness shall vary with the wetwell depth to provide the aggregate strength to meet the tensile and flexural physical property requirements. The basin FRP wall laminate must be designed to withstand wall collapse or buckling based on a hydrostatic pressure of 62.4 pounds per square foot, a saturated soil weight of 120 pounds per cubic foot, a soil modulus of 700 pounds per square foot. Basin must comply with the pipe stiffness values as specified in ASTM D 3753. The basin laminate must be constructed to withstand or exceed 150% of the assumed loading on any depth. The finished FRP laminate will have a Barcol hardness of at least 90 percent of the resin manufacturer's specified hardness for the fully cured resin. The Barcol Hardness shall be the same for both interior and exterior surfaces.

2. All piping inside the basin silhouette shall be at a level in the station that is lower than the frost depth or depth of bury specified for the low-pressure sewer piping, whichever is lowest.
3. The basin package shall be furnished with factory pre-wired junction box. In case of groundwater flooding around grinder station location, the junction box shall be protected from such ground water.
4. Cover shall be an aluminum cover with a hinged access opening to accommodate removal of pumps. Junction box shall be NEMA 6 rated and mounted on the upper rail system cross-member beneath the access opening
5. All discharge pipe shall be constructed of 300 Series Stainless Steel and terminate outside the bulkhead with a stainless steel, female NPT fitting. The manufacturer shall guarantee all bulkhead penetrations to be watertight. Each system shall be equipped with 1.50" Male S.S. NPT x 2.00" female S.S. NPT, 12" length stainless steel flexible discharge coupling to accommodate misalignment to the discharge pipe and to absorb backfill shear forces. The inner corrugated hose and outer braid shall be constructed of 300 series stainless steel and shall have a maximum working pressure of 250 PSI.
6. Each basin shall be equipped with a 300 series stainless steel "C" channel rail assembly to facilitate removal of the pump(s) and level control(s) from ground level. A 1/2" diameter knotted polypropylene rope with a breaking strength of 3,780 lbs. shall be supplied for pump removal and 1/4" diameter knotted polypropylene rope with a breaking strength of 1200 lbs. shall be supplied for level control removal. Removal system must not require the loosening of fasteners to facilitate removal of pump or level control and shall provide for automatic alignment and re-connection of discharge piping for the replacement pump and correct height location for level control. Pump and level control replacement shall be accomplished while the basin is full of sewage without the need to de-water the basin.

## J. Pumps

1. A centrifugal submersible grinder pump shall be provided, specifically designed to reduce all material found in normal domestic sewage, including plastic, rubber, sanitary napkins, and disposable diapers into a finely ground slurry. The pump shall be capable of pumping liquid at temperatures as high as 160°F (71°C) intermittent. The pump shall be capable of running dry for extended periods of time.
2. Pump(s) shall be suitable for long term submergence in sewage. Grinder pump(s) shall be U.L. Listed to Standard 778 and CSA Listed to Standard 108.
3. In order to insure proper operation in all conditions, pump(s) must provide, without overheating in continuous operation, maximum head condition required by the system. Pump(s) must also be capable of operating at zero or negative heads without damage to the pump(s).
4. Pumps shall be Barnes Series OGVF or OGP. The exact model, voltage and horsepower selected for each application shall depend upon projected flow and total dynamic head on the system and shall be subject to the approval of the ENGINEER. If the above model

does not meet the application, ENGINEER shall be notified and alternate models of equal quality shall be presented to the ENGINEER for approval.

**K. Alarm Panel**

1. A wall mounted control panel shall be supplied with each station. All control panels shall be UL Listed to meet Standard 508A. Each panel shall be constructed with a padlockable NEMA 4X fiberglass enclosure and utilize stainless steel hardware.
2. The control panel shall include as a minimum: circuit breakers, fuses, terminal strip, ground lug, capacitors when required, IEC rated motor starters, relays, alarm light, pump alternator, and internal push to run button for each pump. The control panel shall include an elapsed time meter for each pump, controlled by the panel, to indicate pump run time in hours and tenths of an hour. Controls for both pumps must be located in the same enclosure.
3. Each control panel shall include a visual and audible, with silence, high water alarm device. Alarm circuit shall be separately fused from motor control circuit. The visual alarm shall be a red fluted lens mounted to the top of the enclosure in such a manner as to maintain rainproof integrity. The 90 db audible device shall be capable of being deactivated by means of a NEMA 4X silence button mounted on the exterior of the enclosure. Visual alarm will remain on as long as a high water condition exists in the basin. Both visual and audio alarms will automatically reset when the high water condition subsides.
4. A spare pump with complete movable fitting, spare removable float tree, and spare control panel shall be supplied.

**PART 3 - EXECUTION**

**02735.3.01 VALVE INSTALLATION**

Inspect joint surfaces for structural soundness and thoroughly clean before installation. Install valves and accessories in accordance with manufacturer's instructions. Check and adjust valves and accessories for smooth operation.

**02735.3.02 LOW PRESSURE SEWER FORCE MAIN INSTALLATION**

Installation of the low pressure force main within the public right-of-way and AUTHORITY owned easements shall be in accordance with Specification Section 02610, PART 3 - EXECUTION.

**02735.3.03 LOW PRESSURE SEWER FORCE MAIN AND LATERAL TESTING**

Test each newly laid low pressure sewer main, with lateral(s), in accordance with Specification Section 02650. Polyethylene pressure pipe shall be tested in accordance with ASTM F2164.

#### **02735.3.04 VALVE CHAMBER INSTALLATION**

- A. Provide an excavation of sufficient size to accommodate the outside dimensions of the structure as shown on the Drawings. Prior to setting the unit, prepare a 6" stone subbase suitable for receiving the structure. The base material shall be compacted and leveled to the elevation shown on the Drawings.
- B. Provide sufficient labor and equipment to unload and place the units. All precast sections shall be lifted and moved by use of suitable lifting slings and lugs to prevent damage to the precast joint edge. If minor damage occurs to the precast sections, such damage will be repaired in the presence of, and to the satisfaction of the ENGINEER.
- C. Leveling of precast sections by use of wedges or shims will not be permitted. Vaults shall not be backfilled without the permission of the ENGINEER.
- D. Precast bases shall be monolithically cast in accordance with approved Drawings.
- E. All joints between precast sections shall receive a double ring of joint sealant compound. One ring of tape shall be applied to both inside and outside flanges of the precast section groove before lowering the unit in place. Finish the outside of joints between precast concrete sections with "pipeline" tight mortar grout with an epoxy additive as manufactured by Embeco, or equal.
- F. Modular Mechanical Seals: "Popcorn" surfaces or score marks in holes formed in the precast units shall be "battered" in the field to assure good seals. Modular Mechanical Seals shall be Link Seals as manufactured by Eaton's Crouse-Hinds, or approved equal.

#### **02735.3.05 INSTALLATION AND MAINTENANCE OF PRIVATE SEWAGE PUMPING SYSTEM AND FORCE MAIN LATERAL**

- A. No privately owned grinder pump system shall be connected to the public sewer system until the Applicant has: (a) fully complied with regulations and other rules and regulations of the AUTHORITY, local Municipality, and the Pennsylvania Department of Environmental Protection and (b) receives prior written approval of the AUTHORITY through the issuance of a sewer connection permit.
- B. Handling, storage, installation, operation, maintenance, and service of all privately owned pumping systems shall comply with the technical specifications of the grinder pump system manufacturer, as well as the standard specifications, laws and regulations of the AUTHORITY and local Municipality, then in effect.
- C. Homeowner/CONTRACTOR shall not backfill the grinder pump station and low pressure lateral until after examination and approval of the installed facilities by an AUTHORITY field representative and/or local Code Enforcement Officer.
- D. The owner of the property served by a privately owned grinder pump station shall have the responsibility for maintaining, operating, repairing and replacing privately owned grinder pumps and all associated equipment and appurtenances.
- E. The AUTHORITY and the local Municipality shall have no responsibility for the purchase,

operation, repair, or replacement of any privately owned grinder pumps or associated equipment and appurtenances.

- F. The property owner shall be fully responsible for the sewer line and all appurtenances from the structure being served to the public sewer main in a public road right-of-way or an AUTHORITY owned sanitary sewer easement.
- G. Lateral pipe installation shall be in accordance with Section 02610.3.05, except the minimum cover shall be four (4) feet.

### **02735.3.06 RESPONSIBILITY**

- A. All owners of privately owned sewage grinding pumps are hereby required to:
  - 1. Engage the services of a qualified contractor to perform routine maintenance on the pumping system in accordance with the manufacturer's recommendations.
  - 2. Upon indication of any malfunction of the pumping system including backups, the exhibiting of an alarm or any other indication of malfunction, promptly engage a qualified contractor to make repairs to the pumping system.
  - 3. Notify the local government authority of any failure of the pumping system on the next regular business day after the failure occurs. The owner shall further notify the local government authority upon completion of repairs. If pump replacement is required, the pump shall be replaced in kind.
  - 4. Upon discovery by the AUTHORITY of any malfunctions in pumping systems, and after due notice, if repairs are not completed immediately upon complete failure of the pumping system or within three (3) days upon failure of any individual pump in a duplex system, the AUTHORITY shall have the right but not the duty to enter upon the property, make such repairs as are required, [and] charge the cost of such repairs against the property owner, file a municipal claim against the property in the amount of such repair costs to secure repayment of same, and to proceed to collect same per the laws of this Commonwealth pertaining to municipal claims and liens, or by other appropriate legal means.

### **02735.3.07 ABANDONMENT OF EXISTING ON-LOT SEWAGE SYSTEM**

- A. Upon connection of the grinder pump station to the low pressure force main, all existing on-lot sewage disposal systems shall be abandoned by the DEVELOPER/property owner in the following manner (subject to local ordinances and County health department requirements): Remove lid, vent, and access collar of all tanks and/or seepage pits/cesspools. Obtain services of a Sewage Hauler licensed by the County and State to pump out contents. Flush/scrape clean the interior of tanks and drill or break a 6" diameter minimum hole in the bottom. Fill all structures to be abandoned with AASHTO No. 57 stone to a level 6" below surrounding grade. Backfill to grade with 6" of topsoil. Finish grade, seed, and mulch.

- B. DEVELOPER must contact local government authority and schedule site verification of abandonment prior to initiating the work. DEVELOPER will be required to uncover any abandonment work that is completed in the absence of local government authority representatives.

**END OF SECTION**

## **SECTION 02770 SANITARY SEWAGE SPECIALTIES**

### **PART 1 – GENERAL**

#### **02770.1.01 SUMMARY**

Furnish and install all valves, valve chambers, and other piping specialties as specified herein and indicated on the Drawings to provide complete piping systems as intended.

#### **02770.1.02 RELATED INFORMATION**

A. Related Sections:

1. Section 02605 – Manholes and Vaults
2. Section 02610 – Utility Piping and Fittings
3. Section 02650 – Water and Sanitary Sewer System Testing
4. Section 11306 – Sewage Pump Station

B. Associated Construction Details:

1. S-19 – Force Main Air Release Chamber
2. S-20 – Force Main Cleanout Chamber

#### **02770.1.03 QUALITY ASSURANCE**

Products shall be new and the latest standard of reputable manufacturers with replacement parts available. Products contaminated with gasoline, lubricating oil, liquid or gaseous fuels will be rejected.

#### **02770.1.04 SUBMITTALS**

- A. Submit certified dimensional shop drawings and manufacturer's product data on valves and valve operators including assembled weight, construction details, materials of components, and installation instructions.
- B. Submit manufacturer's maintenance instructions and complete parts lists.

#### **02770.1.05 PRODUCT DELIVERY, STORAGE, AND HANDLING**

- A. Deliver valves and accessories to the job site in the manufacturer's boxes or crates. Mark each valve as to size, type, and installation location. Seal valve ends to prevent entry of foreign matter into valve body.
- B. Store valves and accessories in areas protected from weather, moisture, and possible damage. Do not store materials directly on ground.
- C. Handle valves and accessories to prevent damage to interior and exterior surfaces.

## **PART 2 – PRODUCTS**

### **02770.2.01 RESILIENT SEATED GATE VALVES**

- A. Gate valves 12” and smaller shall be iron body, resilient seated solid wedge, non-rising stem gate valves, conforming to AWWA C509 with operating pressure of 250 psi. Buried valves shall have mechanical joint ends and interior valves shall have flanged ends. Furnish valves with a 2" square operating nut. Valve shall be manufactured by Kennedy Valve, Mueller Company, or approved equal.
- B. Gate valves 14” and larger shall be iron body, resilient seated, solid wedge, non-rising stem gate, valves conforming to AWWA C515. Buried valves shall have mechanical joint ends and interior valves shall have flanged ends. Valves 18” and larger shall be provided with bevel gearing and be placed horizontally with the gear box and valve stem installed in a manhole. Furnish valves with a 2" square operating nut. Valves larger than 14” shall be as manufactured by Kennedy Valve, Mueller Company, or approved equal.
- C. Provide 5-1/4" diameter three-piece, cast iron, screw-type adjustable valve boxes with oval base, and one-inch riser ring for all buried gate valves. Valve boxes shall be of sufficient length to reach the surface of the ground, but not extend above the ground surface. The word "SEWER" and a directional arrow indicating the “open” direction shall be cast in the top of the cover. Valve boxes shall be as manufactured by Tyler/Union Company, or approved equal.
- D. Precast concrete manholes required for gate valves 18” and larger shall be provided in accordance with Section 02605.
- E. Refer to Detail W-4 for typical installation of gate valves and valve boxes.

### **02770.2.02 SEWAGE COMBINATION AIR VALVES**

- A. Provide single body, double orifice sewage combination air valves to allow large volumes of air to escape or enter through the large diameter air and vacuum orifice when filling or draining a pipeline. Sewage combination air valves shall also have a small diameter air release orifice to allow small pockets of air to escape when the pipeline is filled and pressurized.
- B. Materials of construction shall be ASTM A126, Class B cast iron body and cover; ASTM A240 stainless steel float and stem; Buna-N needle and seat; ASTM 8124 bronze plug; ASTM 01233 Delrin or cast iron leverage frame, isolation valve so air release can be removed while main is active. Furnish each valve with complete backflushing and cleaning accessories including inlet and outlet valves, quick disconnect coupling, and 5' of hose for flushing.  
  
Inlet Size: 2" NPT  
Outlet Size: 1" NPT
- C. Valves shall be manufactured by APCO Valve and Primer Corporation, Val-Matic Valve and Manufacturing Company, or approved equal.

### **02770.2.03 HOSE END GATE VALVE**

The gate valve to be installed in the Cleanout Chamber shall be a bronze hose end gate valve, with single wedge disc, non-rising stem, female inlet having American Standard taper pipe threads, and outlet having National (American) thread for Fire Hose Couplings and Fittings (ANSI B26) and provided complete with bronze cap and chain. Hose end gate valve shall be Figure 366 Hose Gate Valve with Figure 1309 cap and chain as manufactured by the Lunkenheimer Co., Cincinnati, Ohio, or similar hose end gate valve and cap and chain as manufactured by Walworth or Crane Co., or equal.

The valve shall be designed for a minimum water working pressure of 150 psi and shall be factory tested at a pressure of 300 psi; shall have clean waterway opening of the full nominal diameter of the valve; and shall be opened by turning to the left. The valve shall be handwheel operated and the operating wheel shall have cast thereon an arrow indicating the direction of the opening. The valve shall have the maker's initials, pressure rating, and year of manufacture cast on the body.

### **02770.2.04 CLEANOUT AND AIR VALVE CHAMBERS**

Provide precast concrete manholes with flat slab tops and cast iron manhole frames and covers as specified in Section 02605 and shown on the Drawings.

### **02770.2.05 AIR GAP BACKFLOW PREVENTER**

Connection to drain lines for water softeners, dehumidifiers, washing machines, and other appliances shall be made with an air gap fitting as required by local plumbing code. Air gap fittings shall be as manufactured by Air Gap International, Inc., or approved equal.

### **02770.2.06 PLUG VALVES**

- A. Acceptable Manufacturer: DeZurik, Milliken, or approved equal.
- B. Semi-steel or iron body, permanently lubricated, eccentric plug valves. Valve body shall be furnished with a welded overlay seat of not less than 90% nickel. Plug facing shall be resilient neoprene. Valves through 12" shall be rated for 175 psi working pressure (flow in either direction); valves larger than 12" shall be rated for 150 psi working pressure (flow in either direction). Valves shall be 100 % full pipe area, with rectangular port, and capable of both full shut off and throttling.
- C. Valves shall be gear actuated. Gear actuators shall be grease lubricated, enclosed in a semi-steel sealed housing. Actuator shaft and quadrant shall be supported on permanently lubricated bronze bearings. All nuts, bolts, springs and washers shall be stainless steel. Furnish actuators with adjustable closing torque stop. All gear actuators shall be rated for a minimum pressure differential of 50 psi. Valves and gear actuators shall have seals on all shafts and gaskets on the valve and actuator covers to prevent the entry of water. Actuator mounting brackets shall be totally enclosed and shall have gasket seals. All exposed nuts, bolts, springs and washers shall be stainless steel.
- D. For valves to be buried: Provide with mechanical joint end connections and a 2" square operating nut shall be provided with valve stem extension.

## **PART 3 – EXECUTION**

### **02770.3.01 GENERAL**

Inspect joint surfaces for structural soundness and thoroughly clean before installation. Install valves and accessories in accordance with manufacturer's instructions. Check and adjust valves and accessories for smooth operation.

### **02770.3.02 SETTING VALVES AND VALVE BOXES**

- A. Gate valves shall be provided at 1,000-foot intervals for testing and for isolation purposes or as directed by ENGINEER.
- B. All gate valves shall be set with the stems vertically above the centerline of the pipe. Special care shall be taken to avoid closing valves with sand, stones, or other substances lodged in the valve seat. Valves and valve boxes shall be set plumb, with valve boxes placed directly over the valves. After being correctly positioned at street grade, stone fill shall be carefully compacted around the valve box for a distance of four (4) feet on all sides.

### **02770.3.03 TESTING SEWAGE COMBINATION AIR VALVES**

The sewage combination air valve unit shall be installed in accordance with the installation directions of the manufacturer. The CONTRACTOR will be required to test the valve for proper operation after the valve has been completely installed and at the same time the hydrostatic test of the force main is being performed.

**END OF SECTION**

**SECTION 02832**  
**CHAIN LINK FENCE AND GATES**

**PART 1 - GENERAL**

**02832.1.01 SUMMARY**

- A. Section Includes:
1. Fence framework, coating, and accessories
  2. Excavation for post bases
  3. Concrete anchorage for posts and center drop for gates
  4. Manual gates and related hardware

**02832.1.02 RELATED WORK**

- A. Section 03302 - Concrete Work for Utilities

**02832.1.03 REFERENCES**

- A. ASTM A120 - Pipe, Steel, Black, and Hot-dipped Zinc-coated (Galvanized) Welded and Seamless for Ordinary Uses.
- B. ASTM A123 - Zinc (Hot Galvanized) Coatings on Products, Fabricated from Rolled, Pressed, and Forged Steel Shapes, Plates, Bars, and Strip.
- C. ASTM A446 - Steel Sheet, Zinc Coated by Hot Dipped Process.
- D. ASTM A569 - Steel, Carbon Hot Rolled Sheet and Strip, Commercial Quality.
- E. ASTM A824 - Metallic-Coating Steel Marcellled Tension Wire for Use with Chain Link Fence.
- F. ASTM F567 - Installation of Chain-Link Fence.
- G. ASTM F626 - Fence Fittings.
- H. ASTM F900 - Industrial and Commercial Swing Gates.
- I. FS RR-F-191 - Fencing, Wire and Post, Metal

**02832.1.04 QUALITY ASSURANCE**

- A. Manufacturer: Company specializing in commercial quality chain link fencing with at least two-year's experience.
- B. Installation: ASTM F567

## **02832.1.05 SUBMITTALS**

- A. Submit shop drawing and product data.
  - 1. Cross sectional dimensions of posts, braces, rails, fittings, accessories, and gate frames; design of gates; and details of gate hardware.
  - 2. Spacing of posts and location of gates; abrupt changes in grade; and corner, gate, anchor, end, and pull posts.
  - 3. PVC coating color sample for proposed color.

## **PART 2 - PRODUCTS**

### **02832.2.01 GENERAL**

- A. Fencing shall be chain link type with top rail and shall have a six (6) feet nominal height (if barbed wire is permitted), or eight (8) feet nominal height (if barbed wire is not permitted by Township).
- B. Driveway access gates shall be double section with a width two (2) feet wider than the paving width (minimum width of 12 feet). Personnel access gates shall be three (3) feet wide.

NOTE: Sliding gates on rollers for extra wide openings may be considered and evaluated on an individual site conditions basis.

- C. The choice of finish shall be made on an individual project basis. Sanitary Sewer Pump Stations generally require Type IV finish, Color: Black. Coordinate with the AUTHORITY and ENGINEER.

### **02832.2.02 ACCEPTABLE MANUFACTURERS**

- A. Wheatland Tube
- B. Master Halco
- C. Or any manufacturer that is an active member of the Chain Link Fence Manufacturers Institute (to be approved by ENGINEER).

### **02832.2.03 MATERIALS**

- A. Chain Link Fencing and Accessories: FS RR-F-191 as modified herein.
- B. Fabric: Fabricated from minimum 6-gage, 0.192 inch diameter wire, helically wound and interwoven to provide continuous 2-inch nominal mesh without knots or ties except selvages.
  - 1. Attach tags to every roll, indicating mesh size, coating weight, and wire gage.

2. Height: 8-feet minimum if no barbed wire, unless otherwise specified by the AUTHORITY.
3. Selvage: Twisted and barbed at top and bottom except top selvage may be knuckled when top rail is provided.
4. Individual Fabric Ties: Same material as fabric for attaching fabric to line posts and top and bottom tension wires or rails.
5. Gate Fabric: Same material as for fencing.

C. Frames and Accessories:

1. Posts: Tubular with appropriate caps driven to fit over outside section to exclude moisture, set screw retained.
2. Top and Brace Rails: plain end, sleeve coupled.
3. Tie Rods, Stretcher Bars, Fittings, and Accessories: Shape, dimensions, and weights as specified below.

D. Gates:

1. Frames: Round tubular members, paint welds with zinc-base, aluminum-base, or polyvinyl chloride paint as applicable.
2. Leaves: Space intermediate bracing so no members are more than 8 feet apart.
3. Fabric: Shop-attach gate fabric to gate frame at intervals of not more than 15 inches.
4. Hardware:
  - a. Fork type latch with cavity drop, center gate stop and drop rod
  - b. Mechanical keepers
  - c. Hinges: Full opening with minimum 180-degree swing, of sufficient size and number to prevent twist or turn under action of gate, arranged so closed gate cannot be lifted off its hinges.
  - d. Hardware for padlock: Front gate shall be equipped with a padlock compatible with the AUTHORITY's master key system.

- E. Tension Wire: ASTM A824, 7 gauge, single strand, finish to match fabric.
- F. Type I, Galvanized Steel Fencing: FS RR-F-191; ASTM A120; Schedule 40 steel pipe, standard weight, one piece without joints. [only to be used if specifically requested for a certain project]
  - 1. Fabric: FS RR-F-191/1D, Type I, with minimum zinc coating of 1.2 ounces per square foot.
  - 2. Posts, Top Rails, and Braces: FS RR-F-191/3D, Grade A, with minimum zinc coating of 1.8 ounces per square foot.
    - a. End, Corner, and Pull Post: Class 1, SP4; round, 2.875 inches outside diameter, minimum wall thickness 0.160.
    - b. Line and Intermediate Posts: Class 1, SP2, round, 1.90 inches outside diameter, minimum wall thickness 0.120.
    - c. Gate Posts: Class 1, SP5; round, 4.0 inches outside diameter, minimum wall thickness 0.226, 9.11 lb. per foot of length.
    - d. Top Rails and Braces: Class 1, SP1, round, 1.660 inches outside diameter, minimum wall thickness 0.111.
  - 3. Accessories: FS RR-F-191/4D, with minimum zinc coating of 1.2 ounces per square foot.
  - 4. Gates: FS RR-F-191/2C with same fabric as used for fence.
    - a. Framing: Class 1, SP2, round, 1.90 inches outside diameter, minimum wall thickness 0.120.
    - b. Coating: Zinc coated after fabrication, with minimum zinc coating of 1.8 ounces per square foot.
- G. Type II, Aluminum Alloy or Coated Steel Fencing: manufactured from steel conforming to ASTM A569 or ASTM A446 cold rolled, welded and having a minimum yield strength of 50,000 psi. [only to be used if specifically requested for a certain project]
  - 1. Fabric: FS RR-F-191/1D, Type II or III with minimum aluminum coating on steel wire of 0.40 ounces per square foot.
  - 2. Post, Top Rail, and Braces: FS RR-F-191/3D.
    - a. End, corner, and pull post: Class 2, AP4; round, 2.846 inches outside diameter, 2.004 lb. per foot of length

- b. Line and intermediate posts: Class 2, AP2, round, 1.869 inches outside diameter, 0.940 lb. per foot of length.
    - c. Gate posts: Class 2, AP5, round, 3.960 inches outside diameter, 3.151 lb. per foot of length.
  - 3. Accessories: FS RR-F-191/4D.
  - 4. Gates:
    - a. FS RR-F-191/2D with fabric same as used for fence.
    - b. Framing: Class 2, AP2, round, 1.869 inches outside diameter, 0.940 lb. per foot of length.
- H. Type IV, Polyvinyl Chloride Coated Steel Fencing. [to be used for all pump station projects]
  - 1. Fabric: FS RR-F-191/1D, Type IV, with minimum zinc coating of 0.30 ounces per square foot and minimum PVC coating of 0.007 inch. Color: Black, unless otherwise specified by AUTHORITY.
  - 2. Posts, Top Rail, and Braces: FS RR-F-191/3D with polyvinyl chloride coating thickness of not less than 0.010 inch.
  - 3. Dimensions: Same as required for Type I galvanized steel fencing or Type II aluminum alloy or coated steel fencing.
  - 4. Accessories: FS RR-F-191/4D with polyvinyl chloride coating of not less than 0.007 inch.
  - 5. Gates:
    - a. FS RR-F-191/2D with fabric same as used for fence.
    - b. Dimensions: Same as required for Type I and Type II fencing with polyvinyl chloride coating of not less than 0.010 inch.
- I. Touch-Up Paint.
  - 1. Galvanized: Zinc-rich paint, See ASTM A780.
  - 2. Aluminum: Approved paint recommended by manufacturer.
  - 3. Polyvinyl Chloride: Approved vinyl paint recommended by manufacturer.
- J. Concrete: Class A, 3300 psi, see Section 03302.
- K. Grout: Mixture of 1 part cement to 3 parts concrete sand with required water added for placing.

L. Non-Shrink Grout: See Section 03302.

## **PART 3 - EXECUTION**

### **02832.3.01 INSTALLATION**

- A. Perform necessary clearing, excavation, and filling to provide clear line-of-fence runs.
- B. Install framework, fabric, accessories, and gates in accordance with ASTM F567.
- C. Set gate and corner posts plumb, in concrete footings with top of footing 2 inches above finish grade. Slope top of concrete for water runoff. Footing depth below finish grade: 36 inches with minimum 10-inch diameter for line posts and 12-inch diameter for end, corner, pull, and gate posts. Coat aluminum alloy posts with approved zinc chromate paint from bottom to 2 inches above concrete, prior to placement and touch up with specified aluminum paint after concrete is placed.
- D. Post Placement:
  - 1. Evenly space posts at not more than 10 feet or less than 8 feet on centers. Place additional posts at each change in line and abrupt change in grade.
  - 2. Posts on Concrete Structure: Cast section of steel pipe at least 12 inches long in concrete at correct location for fence posts.
    - a. Steel pipe sleeve: Inside diameter not more than 3/8 inch larger all around than post to be inserted.
    - b. Grout fence posts into steel pipe with non-shrink grout.
  - 3. Set corner or pull posts at each horizontal or vertical angle point of 15 or more degrees.
  - 4. Set corner, end, and pull posts with horizontal or diagonal brace rail and tie rod to nearest line post.
- E. Rails, Tension Wire, and Braces.
  - 1. After posts are installed and concrete has set firmly, place top rail through line post tops and splice with 7-inch long rail sleeves. Install bottom rail or tension wire, as shown on Drawings, approximately 4 inches above grade, stretched taut between terminal posts.
  - 2. Anchor and brace end, corner, and pull posts before hanging fabric.

F. Fabric Placement.

1. Secure ends of fabric using tension bars threaded through loops in fabric, and secure to posts by means of tension bar clips or bands with bolts and nuts.
2. Splice fabric lengths together by reweaving without breaking continuity of knuckled or twisted and barbed selvage.
3. Place fabric by securing one end and applying sufficient tension by means of mechanical fence stretchers to remove slack before making attachments. Stretch fabric between terminal posts or at intervals of 100 feet maximum, whichever is less.
4. Fasten fabric with appropriate tie wires to top rail, line posts, braces, and bottom rail or tension wire at 15 inches on center maximum.
5. Hold bottom of fabric uniformly as possible to 2-inches above finished grade.

G. Gates:

1. Install fence gates with fabric to match fence. Install hinges, latch, catches, drop bolt, gate stops, and keepers.
2. Brace each gate and corner post back to adjacent line post with horizontal center brace rail and diagonal truss rods. Install center and bottom brace rail on gate leaves.
3. Provide concrete center drop to foundation depth and drop rod retainers at center of double gate openings.
4. Locate gate stops set in concrete accurately so that gate stop or latch can be fully engaged.

**02832.3.02 DEFECTIVE WORK**

- A. Remove and replace fencing improperly located, not true to line and grade, and non-plumb posts.
- B. Remove loose and cracked zinc coating and repair damaged galvanizing following ASTM A780, and paint following manufacturer's recommendation.
- C. Repair damaged aluminum coated components by cleaning as specified above, and painting with 2-coats of approved aluminum paint.
- D. Repair damaged polyvinyl chloride by following fence manufacturer's recommendations.

### **02832.3.03 EXISTING CHAIN LINK FENCE**

- A. When required to remove chain link fence to permit construction, remove and store fence to prevent damage.
  - 1. Restore fence to original location following applicable requirements herein or relocate as shown.
  - 2. Repair damaged chain link fence or when directed, replace with applicable in-kind material following requirements specified herein.
- B. When connecting to existing chain link fence, connect as shown on Drawings, or as directed, following requirements specified herein.

**END OF SECTION**

**SECTION 02905  
LANDSCAPING**

**PART 1 – GENERAL**

**02905.1.01 SECTION INCLUDES**

- A. Preparation of soil, placement of plants, ground cover, seed, sod, and fertilizer.

**02905.1.02 RELATED WORK**

- A. Section 02110 - Clearing and Grubbing
- B. Section 02220 - Excavation, Backfill, and Compaction
- C. Section 02250 - Environmental Protection

**02905.1.03 QUALITY CONTROL**

- A. Nursery: Company specializing in growing and cultivating the plant material specified in this Section.
- B. Sod Producer: Company specializing in sod production and certified by the State of Pennsylvania.
- C. Maintenance Services: Performed by CONTRACTOR or CONTRACTOR's agent (i.e., landscape subcontractor) unless otherwise specified.
- D. Reference Standards:
  - 1. Pennsylvania Department of Transportation, Publication 408 Specifications
  - 2. Pennsylvania Soil Conditioner and Plant Growth Substance Law, Act of December 1, 1977, P.L. 258, No. 86 (3P.S.68.2), as amended.

**02905.1.04 WARRANTY**

- A. Plant Material: Provide one year guarantee for plant life which includes one continuous growing season.
- B. Plants replaced under the terms of the guarantee shall be of same size and species as originally specified, planted in the next growing season, with a new warranty commencing on date of replacement.
- C. Seeded or Sodded Areas: Reseed and/or replace sod as required until grass is well established and exhibits a vigorous growing condition.

### **02905.1.05 MAINTENANCE SERVICE**

- A. CONTRACTOR shall be responsible for the maintenance of seeded areas, sodded areas, and plant material until completion and acceptance of the Work by AUTHORITY.

## **PART 2 - PRODUCTS**

### **02905.2.01 GRASS**

- A. Seed Mixture:
  - 1. Permanent: The "Seeding Restoration Table" at the end of this Section lists specific seeding restoration requirements.
  - 2. Temporary Stabilization: Utilize Formula E as set forth in the "Seeding Restoration Table" at the end of this Section.
- B. Sod: ASPA/Pennsylvania certified, nursery grown cultivated grass sod; with strong fibrous root system. Sod mixture shall be specified as being hardy for the region of installation.

### **02905.2.02 TREES, PLANTS, AND GROUND COVER**

- A. Landscape Plant Material and Ground Cover: Plant material specified on plant list indicated on Drawings shall be symmetrical in growth, true to species, variety and sire, nursery grown in climatic conditions similar to region of installation and be free of any pests or disease.

### **02905.2.03 SOIL AND SOIL ENHANCEMENT MATERIALS**

- A. Topsoil: Fertile, agricultural soil, typical for locality, capable of sustaining vigorous plant growth, free of subsoil, clay or impurities, plants, weeds and roots or other foreign materials.
- B. Fertilizer:
  - 1. Basic Fertilizer: Analysis 0-20-200 and as defined by the Pennsylvania Soil Conditioner and Plant Growth Substance Act.
  - 2. Starter Fertilizer: Analysis 10-5-5 or 12-6-6 and as defined by the Pennsylvania Soil Conditioner and Plant Growth Substance Act.
- C. Lime: Raw ground limestone conforming to Section 804.2(a), Publication 408 Specifications.

#### **02905.2.04 ACCESSORIES**

- A. Wood Pegs: Softwood, sufficient size and length to ensure anchorage of sod on slope.
- B. Mesh: interwoven plastic.

### **PART 3 - EXECUTION**

#### **02905.3.01 EXAMINATION AND PREPARATION**

- A. Prepare subsoil to eliminate uneven areas. Maintain profiles and contours. Make changes in grade gradual. Blend slopes into level areas.
- B. Scarify subsoil to a depth of three (3) inches.

#### **02905.3.02 PLACING TOPSOIL AND TILLAGE**

- A. Spread topsoil to a minimum depth of six (6) inches to obtain the required grade elevation.
- B. Apply lime at a rate of 90 pounds per 1,000 square feet, if necessary, to raise pH to between 6.5 and 7.0.
- C. Apply basic fertilizer in accordance with manufacturer's instructions at an application rate of 25 pounds per 1,000 square feet.
- D. Thoroughly loosen soil and incorporate lime and basic fertilizer to a minimum depth of four (4) inches by discing, harrowing, or other approved method.

#### **02905.3.03 FINISH GRADING**

- A. Hand rake topsoil and remove all unsuitable materials.
- B. Uniformly grade topsoil to eliminate rough, low, or soft areas and to ensure positive drainage.
- C. Apply starter fertilizer at an application rate of 10 pounds per 1,000 square feet and incorporate into soil.

#### **02905.3.04 SEEDING**

A. Apply seed within the following time periods unless otherwise directed by ENGINEER.

\* Formula B, D, and L: March 15 to June 1  
August 1 to October 15

\* Formula C - Ryegrass Portion: March 1 to October 15

Crownvetch Portion: Anytime except September and October

\* Formula E: March 15 to October 15

\* Formula W: April 1 to June 15  
August 16 to September 15

Formula E (Annual ryegrass) to be utilized for temporary stabilization of areas disturbed by construction and may be applied anytime.

B. Seeding Rates:

1. Permanent - Apply seed or hydroseed with a seed slurry evenly in two intersecting directions at the rate noted in the Seeding Restoration Table unless an alternate seeding rate appropriate for site conditions is approved by ENGINEER.
2. Temporary Stabilization: Apply seed or hydroseed with a seed slurry at the rate noted in the Seeding Restoration Table.

C. Immediately following permanent or temporary seeding, apply agricultural mulch at a minimum rate of 135 pounds per 1,000 square feet.

1. Apply water with a fine spray immediately after each area has been mulched.

#### **02905.3.05 LAYING SOD**

A. Moisten prepared surface immediately prior to laying sod.

B. Lay sod within 24 hours after harvesting with tight staggered joints.

C. On slopes 1:2 and steeper, place mesh over top soil, lay sod perpendicular to slope and secure every row with wooden pegs.

D. Water sodded areas immediately after placement.

#### **02905.3.06 PLANTING**

A. Set plants in pits or beds, partly filled with prepared backfill soil mixture.

- B. Saturate soil with water when the pit or bed is half full of backfill soil mixture and again when ball is covered.

#### **02905.3.07 MAINTENANCE**

- A. The CONTRACTOR shall take all necessary precautions to protect trees, shrubs, grassed areas, and all landscaping from damage. Any damages caused by the CONTRACTOR to these features shall be repaired or replaced at the CONTRACTOR's expense.
- B. The CONTRACTOR shall properly water, mow, rake, weed, and otherwise maintain the grass until dedication of facilities.
  - 1. Water to prevent grass and soil from drying out.
  - 2. Mow the grass at regular intervals to maintain a maximum height of 2-1/2 inches. Do not cut more than 1/3 of grass blade at any one mowing.
  - 3. Control growth of weeds. Apply herbicides and pesticides in accordance with manufacturer's instructions.
- C. Any areas that fail to show a uniform stand of grass shall be reseeded and re-fertilized until an acceptable stand of grass exists.

#### **02905.3.08 SCHEDULE - SEED FORMULA**

- A. See Drawings for seeding restoration requirements at each specific location of Work; otherwise, use Formula D for shady areas and Formula B for sunny areas.

#### **02905.3.09 SCHEDULE - SOD**

- A. See Drawings for areas where sod is to be utilized.

#### **02905.3.010 SCHEDULE - PLANT LIST**

- A. See Schedule on Drawings listing type and locations of various plant life.

**NOTE: SEEDING RESTORATION TABLE IS ATTACHED AT END OF THIS SECTION.**

**SEEDING RESTORATION TABLE \*\***

FORMULA AND SPECIES	% BY WEIGHT	MINIMUM %		MAX % WEED SEED	SEEDING RATE LBS. PER 1,000 SY
		PURITY	GERMINATION		
<u>Formula B</u> * Perennial Ryegrass Mixture ( <i>Lolium perenne</i> ) A combination of improved certified varieties with no one variety exceeding 50% of the total ryegrass component	20	98	90	0.15	4.0
* Creeping Red Fescue or Chewings Fescue	30	98	85	0.15	6.0
* Kentucky Bluegrass Mixture ( <i>poa pratensis</i> ) A combination of improved certified varieties with no one variety exceeding 25% of the total bluegrass component.	50	98	80	0.20	<u>11.0</u>
					TOTAL 21.0
<u>Formula C</u> * Crownvetch ( <i>Coronilla varia</i> )	45	99	70	0.10	4.0
* Annual Ryegrass ( <i>Lolium multiflorum</i> )	55	98	90	0.15	<u>5.0</u>
					TOTAL 9.0
<u>Formula D</u> * Tall Fescue ( <i>Festuca arundinacea</i> var. Kentucky 31)	70	98	85	0.15	15.0
* Creeping Fed Fescue or Chewings Fescue	30	98	85	0.15	<u>6.0</u>
					TOTAL 21.0
<u>Formula E</u> *Annual Ryegrass ( <i>Lolium multiflorum</i> )	100	98	85	0.15	<u>10.0</u>
					TOTAL 10.0
<u>Formula L</u> *Hard Fescue Mixture ( <i>Festuca longifolia</i> ) A combination of improved certified varieties with no one variety exceeding 50% of the total hard fescue component.	60	98	85	0.15	12.5
*Creeping Red Fescue	40	98	85	0.15	<u>8.5</u>
					TOTAL 21.0
<u>Formula W</u> *Tall Fescue ( <i>Festuca arundinacea</i> var. Kentucky 31)	70	98	85	0.15	7.5
*Birdsfoot Trefoil Mixture ( <i>Lotus corniculatus</i> ) A mixture of ½ Viking and ½ of either Empire, Norcen, or Leo	20	98	80*	0.10	2.0
*Redtop ( <i>Agrostis alba</i> )	10	92	80	0.15	<u>1.0</u>
					TOTAL 10.5

\*Minimum 20% hardseed and 60% normal sprouts.

\*\*This table has been extracted from PennDOT Publication 408 (see Section 804 as supplemented April 26, 1993)

**END OF SECTION**

**SECTION 03302  
CONCRETE WORK FOR UTILITIES**

**PART 1 - GENERAL**

**03302.1.01 SUMMARY**

A. The Work of this section involves cast-in-place concrete construction associated with utilities which includes, but is not limited to:

1. Base slabs
2. Cradles and encasements
3. Reaction and support blocking
4. Fillets, benches, and miscellaneous
5. Pavement restoration

**03302.1.02 RELATED INFORMATION**

A. Related Work Specified Elsewhere:

1. Section 02170 - Stream Crossing
2. Section 02220 - Excavation, Backfill & Compaction
3. Section 02300 - Boring and Jacking Operations
4. Section 02575 - Restoration of Paved Surfaces
5. Section 02610 – Utility Pipe and Fittings
6. Section 02605 – Manholes and Vaults
7. Section 02832 - Chain Link Fence and Gates
8. Section 11306 - Sewage Pumping Station

**03302.1.03 QUALITY ASSURANCE**

A. Reference Standards:

1. Pennsylvania Department of Transportation - Publication 408 Specifications
2. American Society for Testing and Materials (ASTM):  
  
A615 - Specification for Deformed and Plain Billet - Steel Bars for Concrete Reinforcement  
  
C31 - Making and Curing Concrete Test Specimens in the Field  
  
C39 - Test for Compressive Strength of Cylindrical Concrete Specimens  
  
C42 - Obtaining and Testing Drilled Cores and Sawed Beams of Concrete  
  
C172 - Sampling Fresh Concrete
3. All concrete shall be plant mixed and transported to the site by truck mixers unless CONTRACTOR requests and receives approval from the ENGINEER prior to Work.

#### **03302.1.04 SUBMITTALS**

##### **A. Certificates:**

1. Submit certification from the concrete producer attesting that the cement concrete conforms to Section 704, Publication 408 Specifications for the class of concrete being used.
2. Submit certified results of compressive strength tests performed by an independent testing laboratory.

#### **PART 2 - PRODUCTS**

#### **03302.2.01 CEMENT CONCRETE**

##### **A. Ready-mixed, conforming to Section 704, Publication 408 Specifications and ASTM C94.**

1. Requirements for State approved batch plants, design computations and plant inspection shall not apply. The acceptability of concrete will be based on conformance with the Cement Concrete Criteria specified below and the results of the specified tests.

##### **B. Cement Concrete Criteria:**

1. Class A (equipment pads, cast-in-place manhole inverts, etc.)
  - a. 28-day compressive strength: 3300 psi
  - b. Slump: 1 to 3 inches
2. Class C (non-reinforced encasements, etc.)
  - a. 28-day compressive strength: 2000 psi
  - b. Slump: 2 to 6 inches
3. High Early Strength
  - a. 3-day compressive strength: 3000 psi
  - b. Slump: 1 to 3 inches
4. Cement Factor and Maximum Water-Cement Ratio conforming to Table A, Section 704.1 (b), Publication 408 Specifications.

#### **03302.2.02 REINFORCEMENT STEEL**

##### **A. Reinforcement Bars:**

1. ASTM A615, Grade 60, deformed billet steel bars, finish conforming to Section 709.1, Publication 408 Specifications.

B. Welded Steel Wire Fabric

1. Plain type; unfinished conforming to gage and mesh size as noted on the Drawings and Sections 709.3 and 790.4, Publication 408 Specifications, and ASTM-A185 Welded Steel Wire Fabric for Concrete Reinforcement.

**PART 3 - EXECUTION**

**03302.3.01 CONSTRUCTION**

- A. Comply with Section 1001, PennDOT Publication 408 Specifications for construction requirements including form work, curing, protection and finishing of cement concrete
- B. Excavate and shape bottoms and sides of excavation to accommodate thrust block forms, cradles and encasements, manhole bases, and base slabs.
- C. Support pipe, valves and fittings where installed at the required elevation with brick or concrete block. Do not use earth, rock, wood, or organic material as supports.
- D. Provide spaces, chairs, bolsters, ties and other devices for properly placing, spacing, supporting and fastening reinforcement in place.
- E. Construct base slabs, manhole bases, end walls, curbs, sidewalks, miscellaneous reinforced structures, and miscellaneous exposed mass concrete of Class A concrete.
- F. Construct reaction and support blocking, cradles, encasements, and miscellaneous buried mass concrete of Class C concrete.
- G. Construct reinforced and plain cement, concrete pavements and base courses of High Early Strength concrete as specified in Section 02575, Restoration of Paved Surfaces.
- H. A delivery ticket indicating the mix (including maximum size of aggregate and amount of mix water), design strength of the concrete, design slump, and time of leaving in the truck mixer shall be submitted with each batch at the time of delivery. Failure to render such ticket to the CONTRACTOR's Superintendent shall automatically be cause for rejection of the concrete. The CONTRACTOR's Superintendent shall write on the back of the delivery ticket:
  - a) the time of arrival of the truck mixer on the site;
  - b) the time of deposit of the concrete; and
  - c) the place of deposit of the concrete.

The completed delivery ticket shall be promptly delivered to the ENGINEER's Resident Project Representative. Failure to deliver such completed ticket will be cause for the ENGINEER to reject the deposited concrete at any time and cause it to be removed and replaced at the CONTRACTOR's expense. No concrete shall be deposited on the job when it has contained its mix water longer than 60 minutes.

- I. Place concrete utilizing all possible care to prevent displacement of all pipe or fittings. Return displaced pipe or fittings to line and grade immediately. Once concreting is started, it shall be carried on as a continuous operation until the placing of the panel or sections is completed. No concrete that has partially hardened or been contaminated by foreign material shall be deposited in the work.
- J. The top surface of vertically formed lifts shall be generally level. When construction joints are necessary, they shall be placed in accordance with PADOT Publication 408.
- K. All concrete shall be thoroughly consolidated with the aid of approved mechanical vibrating equipment during placement and shall be thoroughly worked around the reinforcement and embedded fixtures and into the corners of the forms. Vibration shall be transmitted directly to the concrete and in no case shall be transmitted through the forms. The duration of the vibration at any location in the forms shall be held to a minimum necessary to produce thorough compaction.
- L. Insure tie rods, nuts, bolts and flanges are free and clear of concrete.
- M. All equipment concrete pads shall have a height of four inches above the finished slab elevation, unless shown differently on the Drawings. The pad shall be separated from the concrete slab by one-half inch expansion joint and the pad shall extend two inches beyond the foundations of the items they are supporting. The edges of the pad shall be finished with a one-half inch chamfer.
- N. Unless otherwise approved by ENGINEER, during curing the concrete shall be maintained above 50° and in a moist condition for at least the first seven (7) days after placing, except that high-early strength concrete shall be so maintained for at least the first three (3) days.
- O. All floor slabs shall be finished as follows: screed, float and trowel monolithic slab to proper elevations and/or grades; then steel troweled to a hard, dense, polished finish. All slopes must be true and must allow for proper drainage at all times.
- P. Exposed surfaces shall receive a rubbed smooth finish subject to approval of the ENGINEER. Exterior concrete slabs and platforms shall receive a wood floated finish worked in such a manner as to result in a coarse-textured surface that will resist slipping.
- Q. Do not backfill structures until concrete has achieved its initial set, forms are removed, and concrete work is inspected by the Resident Project Representative.
- R. Perform backfilling and compaction as specified in Section 02220.

### **03302.3.02 FIELD TESTS OF CONCRETE DURING CONSTRUCTION**

- A. Test each 50 cubic yards or fraction thereof or as directed by the ENGINEER for each class of concrete for compressive strength. Retain an independent testing laboratory to test cylinders at the expense of CONTRACTOR.
1. Sample concrete in accordance with ASTM 0172.
  2. Prepare and cure two (2) test cylinders in accordance with ASTM C31.
  3. Test cylinders in accordance with ASTM C39
- B. If test cylinders fail to meet strength requirements, the ENGINEER may require additional core tests in accordance with ASTM C122 at the expense of the CONTRACTOR.

**END OF SECTION**

## **SECTION 09900**

### **PAINTING**

#### **PART 1 - GENERAL**

##### **09900.1.01 DESCRIPTION**

- A. The work of this section shall consist of furnishing all paint, labor, supervision, materials and equipment necessary to perform all painting and to apply protective coatings, complete as shown on Drawings and as specified herein. The number of coats as specified in this section is in addition to any coats specified under other sections.
- B. The term "paint" as used herein includes emulsions, enamels, epoxies, paints, stains, varnishes, sealers and other coatings, whether organic or inorganic, indicated in these Specifications and the Drawings as prime, intermediate or finish coats.
- C. Examine Specifications for all trades and become thoroughly familiar with provisions regarding painting. All surfaces that are left unfinished in other sections shall be painted or finished as specified herein. Any fabricated items such as miscellaneous iron and steel, door frames, millwork, etc., that are delivered without shop or prime coats as required by their respective sections, shall be immediately primed on delivery.
- D. The painting of all surfaces damaged or marked due to construction operations shall be included in this section. All damaged surfaces shall be painted to give a "like-new" appearance and to produce a finish equal to new work as specified herein.
- E. In general, the following surfaces are to be painted. This list includes the major items of the work but does not necessarily include every item that will require painting. All surfaces requiring protection shall be painted, even though not specifically defined herein.
  - 1. All exposed ferrous metal surfaces including structural steel and metal fabrications.
  - 2. All equipment and machinery furnished and installed without factory finished surfaces or having factory finishes which are required to match associated piping or surrounding walls/ceilings.
  - 3. All exposed piping, valves, piping specialties, supports, conduits, and other metal surfaces, interior and exterior.
  - 4. The interior floor and wall surfaces of buildings.
  - 5. All surfaces requiring safety color coding in accordance with applicable standards.
  - 6. Gypsum wallboard ceilings.

- F. The following surfaces or equipment are not to be painted.
1. All equipment and items with factory finish with the exception of those primed only for finish painting on the job site, or when factory finish is required on the Drawings to match adjacent surrounding walls or ceilings.
  2. Any surface noted on the Drawings not to be painted.
  3. Nameplates
  4. Non-ferrous metals including aluminum, brass, bronze, chromium plate, nickel, and Monel metal unless specified otherwise.
  5. Plumbing and electrical fixtures.
  6. Stainless steel and galvanized steel, other than what is specified above
  7. Concrete surfaces not otherwise specified
  8. Brick and decorative masonry surfaces
  9. Fiberglass surfaces
  10. Treated wood
  11. Grease fittings
  12. Glass
  13. Gratings, stair treads, door thresholds, and other similar walk surfaces.
  14. Submerged plastic piping

**09900.1.02 SECTION INCLUDES**

- A. Surface preparation.
- B. Field application of paints, and other coatings.

**09900.1.03 REFERENCES**

- A. 10 States Standards - Recommended Standards for Wastewater Facilities (2004) Section 54.5
- B. 10 States Standards - Recommended Standards for Water Works Section 2.14
- C. ANSI A13.1 - Scheme for the Identification of Piping Systems
- D. ASTM D16 - Standard Terminology Relating to Paint, Varnish, Lacquer, and Related Products.

- E. ASTM D4442 - Standard Test Methods for Direct Moisture Content Measurement of Wood and Wood-Base Materials.
- F. NACE (National Association of Corrosion Engineers) - Industrial Maintenance Painting.
- G. NPCA - Guide to U.S. Government Paint Specifications; National Paint and Coatings Association.
- H. PDCA - Architectural Specifications Manual; Painting and Decorating Contractors of America.
- I. OSHA 1910.144 10 - Safety Color Code for Marking Physical Hazards
- J. SSPC - Steel Structures Painting Manual; Steel Structures Painting Council.
- K. SSPC Volume 2 - Systems and Specifications, Surface Preparation Guide and Paint Application Specifications

#### **09900.1.04 QUALITY ASSURANCE**

- A. All safety rules and regulations of the OWNER and the applicable federal, state and local laws, including OSHA regulations and insurance and underwriters requirements shall be strictly observed by personnel engaged in the storing, handling, use and application of paints, thinners and solvents. Particular reference is made to the use of adequate respirators and ventilation equipment, when required.
- B. Each paint container shall include a label indicating manufacturer's name, type of paint, manufacturer's stock number, color, and instructions for reducing where applicable.
- C. Manufacturer Qualifications: Company specializing in manufacturing the Products specified in this section with minimum three years' experience.
- D. Applicator Qualifications: Company specializing in performing the work of this section with minimum five year's experience.

#### **09900.1.05 SUBMITTALS**

- A. In accordance with Section 01010, submit manufacturer's product data for each paint system and pipe marker system listing material properties, application instructions, and environmental conditions required for use. Include color charts for each paint system and pipe marker system for selection of colors.
- B. Submit a schedule with designations for all process piping to be identified on this project.
- C. CONTRACTOR shall leave on the job site a minimum of one gallon of each type and color of finish paint used on this project. Each gallon shall be properly labeled for identification and be in its original container.

## **09900.1.06 PRODUCT DELIVERY, STORAGE, AND HANDLING**

- A. All material shall be delivered to the site in the manufacturer's sealed containers with the labels legible and intact. All materials shall be subject to inspection and approval of the ENGINEER before being used.
- B. All painting materials shall be stored and mixed in a single place designated by the ENGINEER for that purpose. The CONTRACTOR shall not use any plumbing fixture or pipe for mixing or for disposal of any refuse material. CONTRACTOR shall carry to CONTRACTOR's mixing room all water necessary, and shall dump all waste outside of the building into a suitable receptacle. Every caution shall be taken to avoid fire and a suitable fire extinguisher maintained outside the door where paint is stored. The CONTRACTOR will be held responsible for any damage due to CONTRACTOR's failure to observe these provisions.

## **09900.1.07 ENVIRONMENTAL REQUIREMENTS**

- A. Do not apply materials when surface and ambient temperatures are outside the temperature ranges required by the paint product manufacturer.
- B. Do not apply exterior coatings during rain or snow, or when relative humidity is outside the humidity ranges required by the paint product manufacturer.
- C. Minimum Application Temperatures for Latex Paints: 45 degrees F (7 degrees C) for interiors; 50 degrees F (10 degrees C) for exterior; unless required otherwise by manufacturer's instructions.

## **PART 2 - PRODUCTS**

### **09900.2.01 MANUFACTURERS**

- A. Manufacturers - Paint:
  - 1. Sherwin-Williams
  - 2. MAB-Pennsbury Coatings
  - 3. Tnemec Company, Inc.
  - 4. Or approved equal.

Note: All trade names listed in the schedule (Sections 3.8 and 3.9) below, are Sherwin-Williams products unless otherwise indicated. Equivalent MAB-Pennsbury or Tnemec products, are also acceptable.

## **09900.2.02 MATERIALS**

- A. All paint materials required shall be of the type and grade specified, factory-mixed, and ready for application. Paint materials shall include all vehicles, pigments, shellacs, varnishes, lacquers, etc. required for the sealing, protecting, coloring and general finishing of finished surfaces which depend upon evaporation or oxidation in air for their setting or drying. It does not include products which require a catalyst or contain epoxies or coatings of finishes which, because of their nature, require application by applicators specially licensed by the manufacturer or distributor.
- B. No claim covering the unsuitability of any materials specified will be entertained unless such claim is made in writing, before the work is commenced or material is ordered and the same brought to the attention of the ENGINEER whose decisions shall be final and binding.
- C. All white and light tints shall be non-yellowing and non-chalking.
- D. The material for each coat, location, and usage shall be as designated for the purpose by the above manufacturers, as specifically stated in their published specifications. Intermixing, etc. shall be done only in accordance with the manufacturer's directions.
- E. Coatings: Ready mixed, except field catalyzed coatings. Prepare pigments:
  - 1. To a soft paste consistency, capable of being readily and uniformly dispersed to a homogeneous coating.
  - 2. For good flow and brushing properties.
  - 3. Capable of drying or curing free of streaks or sags.
- F. Accessory Materials: Linseed oil, shellac, turpentine, paint thinners and other materials not specifically indicated but required to achieve the finishes specified; commercial quality.
- G. Patching Materials: Latex filler.
- H. Fastener Head Cover Materials: Latex filler.

## **09900.2.03 FINISHES**

- A. Refer to schedule at end of this Section for surface finish. Colors will be determined during shop drawing approvals.

## **PART 3 - EXECUTION**

### **09900.3.01 EXAMINATION**

- A. Verify that surfaces and/or substrate conditions are ready to receive Work as instructed by the product manufacturer.

- B. Examine surfaces scheduled to be finished prior to commencement of work. Report any condition that may potentially affect proper application.
- C. Test shop applied primer for compatibility with subsequent cover materials.
- D. Measure moisture content of surfaces using an electronic moisture meter. Do not apply finishes unless moisture content of surfaces are below the following maximums:
  - 1. Plaster and Gypsum Wallboard: 12 percent.
  - 2. Masonry, Concrete, and Concrete Unit Masonry: 12 percent.
  - 3. Interior Wood: 15 percent, measured in accordance with ASTM D4442.
  - 4. Exterior Wood: 15 percent, measured in accordance with ASTM D4442.
  - 5. Concrete Floors: 8 percent.

**09900.3.02 PROTECTION OF WORK**

- A. Lay drop cloths in all areas where painting is being done. All adjacent surfaces not being painted shall be carefully protected. Where it becomes necessary to remove previously erected temporary coverings placed by other trades, these shall be replaced in a proper manner. In case these coverings cannot be replaced, the work shall be protected in some other satisfactory manner.
- B. Concrete floors shall be left in perfect condition and covered with clean building paper, which shall be kept in place until the entire work has been completed and accepted.
- C. CONTRACTOR shall be responsible for any damage done to the work of other trades as a result of painting and finishing work and CONTRACTOR shall repair or replace the work to the satisfaction of the ENGINEER. Particular care shall be taken to protect equipment and electrical nameplates from being obscured by paint.
- D. Upon completion of the painting, all metal, hardware, etc. which cannot be easily cleaned of all paint spots, oil and stains, will be considered as damage to the work of other trades and shall be repaired or replaced to the satisfaction of the ENGINEER.
- E. Hardware, hardware accessories, plates, lighting fixtures, and similar items in place shall be removed prior to painting, or otherwise protected during painting operations, and shall be repositioned upon completion of each space.
- F. Aluminum in Contact with Dissimilar Materials:
  - 1. Where aluminum is in contact with steel members or other dissimilar materials, keep the aluminum from directly contacting the steel or the other dissimilar metals by painting as follows:
    - a. Paint steel surfaces, to be placed in contact with aluminum, with good quality priming paint, such as zinc chromate primer in accordance with Federal Specification TT-P-645, followed by two coats of paint consisting of 2 lb. of aluminum paste pigment (ASTM Specification 0962-66, Type 2, Class B) per gallon of varnish meeting Federal Specification TT-V-81, Type II or the

equivalent. Aluminized, hot-dip galvanized, electro-galvanized steel or stainless steel (300 series) placed in contact with aluminum need not be painted except in high chloride containing environments.

- b. Do not place aluminum in direct contact with wood, fiberboard or other porous material that may absorb water and cause corrosion. When such contacts cannot be avoided, install an insulating barrier between the aluminum and the porous material. Give aluminum surfaces a heavy coat of alkali resistant bituminous paint or other coating providing equivalent protection before insulation. Aluminum in contact with concrete or masonry should be similarly protected.
- c. Aluminum surfaces to be embedded in concrete: Paint aluminum surfaces with one coat of suitable quality paint such as zinc chromate primer conforming to Federal Specification IT-P-645 or apply a heavy coating of alkali resistant bituminous paint, or wrap aluminum with a suitable plastic tape applied in such a manner as to provide adequate protection to the overlaps.

### **09900.3.03 VENTILATION**

CONTRACTOR shall not permit painting to begin in enclosed places until a forced draft ventilation system of sufficient air volume has been placed in operation.

### **09900.3.04 PREPARATION**

- A. Surface Appurtenances: Remove or mask electrical plates, hardware, light fixture trim, escutcheons, and fittings prior to preparing surfaces or finishing.
- B. Surfaces: Correct defects and clean surfaces which affect work of this section. Remove or repair existing coatings that exhibit surface defects.
- C. Marks: Seal with shellac wood surfaces, which may bleed through surface finishes.
- D. Impervious Surfaces: Remove mildew by scrubbing with solution of tri-sodium phosphate and bleach. Rinse with clean water and allow surface to dry.
- E. Aluminum Surfaces Scheduled for Paint Finish: Remove surface contamination by steam or high pressure water. Remove oxidation with acid etch and solvent washing. Apply etching primer immediately following cleaning.
- F. Asphalt, or Bituminous Surfaces Scheduled for Paint Finish: Remove foreign particles to permit adhesion of finishing materials.
- G. Insulated Coverings: Remove dirt, grease, and oil from canvas and cotton.
- H. Concrete Floors: Remove contamination, acid etch, and rinse floors with clear water. Verify required acid-alkali balance is achieved. Allow to dry.
- I. Copper Surfaces Scheduled for Paint Finish: Remove contamination by steam, high pressure water, or solvent washing. Apply vinyl etch primer immediately following cleaning.

- J. Copper Surfaces Scheduled for a Natural Oxidized Finish: Remove contamination by applying oxidizing solution of copper acetate and ammonium chloride in acetic acid. Rub on repeatedly for required effect. Once attained, rinse surfaces with clear water and allow to dry.
- K. Gypsum Board Surfaces: Fill minor defects with thin layers of drywall joint cement. Allow layer to dry before sanding smooth. Do not raise nap of paper on wallboard. Spot prime defects after repair.
- L. Galvanized Surfaces: Remove surface contamination and oils and wash with solvent. Apply coat of etching primer.
- M. Concrete and Unit Masonry Surfaces Scheduled to Receive Paint Finish: Remove dirt, loose mortar, scale, salt or alkali powder, and other foreign matter. Remove oil and grease with a solution of tri-sodium phosphate; rinse well and allow to dry. Remove stains caused by weathering of corroding metals with a solution of sodium metasilicate after thoroughly wetting with water. Allow to dry.
- N. Plaster Surfaces: Fill hairline cracks, small holes, and imperfections with latex patching plaster. Make smooth and flush with adjacent surfaces. Wash and neutralize high alkali surfaces.
- O. Uncoated Steel and Iron Surfaces: Remove grease, mill scale, weld splatter, dirt, and rust. Where heavy coatings of scale are evident, remove by power tool wire brushing or sandblasting; clean by washing with solvent. Apply a treatment of phosphoric acid solution, ensuring weld joints, bolts, and nuts are similarly cleaned. Spot prime paint after repairs.
- P. Shop Primed Steel Surfaces: Sand and scrape to remove loose primer and rust. Feather edges to make touch-up patches inconspicuous. Clean surfaces with solvent. Prime bare steel surfaces. Prime metal items including shop primed items.
- Q. Interior Wood Items Scheduled to Receive Paint Finish: Wipe off dust and grit prior to priming. Seal knots, pitch streaks, and sappy sections with sealer. Fill nail holes and cracks after primer has dried; sand between coats.
- R. Interior Wood Items Scheduled to Receive Transparent Finish: Wipe off dust and grit prior to sealing, seal knots, pitch streaks, and sappy sections with sealer. Fill nail holes and cracks after sealer has dried; sand lightly between coats.
- S. Exterior Wood Scheduled to Receive Paint Finish: Remove dust, grit, and foreign matter. Seal knots, pitch streaks, and sappy sections. Fill nail holes with tinted exterior calking compound after prime coat has been applied.
- T. Metal Doors Scheduled for Painting: Prime metal door top and bottom edge surfaces.

### **09900.3.05 WORKMANSHIP**

- A. All workmanship shall be of the highest standard, with all material evenly spread and thoroughly brushed or sprayed on as specified below, without runs. Coverage of all painting shall be to the satisfaction of the ENGINEER.

- B. On metal surfaces, each coat of paint shall be applied at the rate specified by the manufacturer to achieve the minimum dry mil thickness required. Deficiencies in film thickness shall be corrected by the application of an additional coat of paint. Where conditions are other than normal because of the weather or because painting must be done in confined spaces, longer drying times will be necessary. Additional coats of paint shall not be applied, nor shall units be returned to service until paints are thoroughly dry.
- C. Job mixing and job tinting of material may be done only when approved and directed by the ENGINEER. Where thinning is necessary, only products recommended by the manufacturer furnishing the paint will be allowed. All such thinning shall be done in accordance with the manufacturer's instructions, as well as with the knowledge and approval of the ENGINEER.
- D. Apply no exterior paint in frost, damp or rainy weather. Paint shall not be applied below 50 degrees F nor when a temperature drop of 20 degrees F is forecast. Manufacturer's application recommendations shall be followed.
- E. If metal or any other surface to be finished cannot be put in proper condition by customary cleaning and sanding operations, CONTRACTOR shall immediately notify the ENGINEER in writing. If, however, CONTRACTOR should apply the finish to any unsatisfactory surface, CONTRACTOR shall assume full responsibility for same and shall rectify any unsatisfactory finish resulting, to the complete satisfaction of the ENGINEER.
- F. All surfaces to be painted shall be prepared in a workmanlike manner with the objective of obtaining a clean and dry surface. Cleaning and painting shall be programmed and no painting shall be done before the prepared surfaces are approved by the ENGINEER.
- G. The priming coats shall be tinted to the approximate shade of the final coat. All section coats or hot spots appearing after the application of the first coat shall be touched up to produce an even result in the finish coat.
- H. Where a coat of material has been applied, it must be inspected and approved by the ENGINEER before the application of the succeeding specified coat.
- I. CONTRACTOR shall not only protect the work at all times, but shall also protect all adjacent work and materials by suitable covering or other methods during the progress of the work. Upon completion of the work, CONTRACTOR shall remove all paint spots from the floors and other surfaces. CONTRACTOR shall remove from the premises all rubbish and accumulated materials caused by the work done under this section and shall leave the work in a clean, orderly and acceptable condition.
- J. All work shall be entirely free of brush marks, runs, dust and other imperfections.
- K. The number of coats specified is the minimum number acceptable, and are intended to produce a fully covered, workmanlike presentable job. Additional coats are to be applied where required to obtain these results, at CONTRACTOR's expense.

### **09900.3.06 APPLICATION**

- A. Apply products in accordance with manufacturer's instructions.
- B. Do not apply finishes to surfaces that are not dry. Allow applied coats to dry before next coat is applied.
- C. Apply each coat to uniform appearance. Apply each coat of paint slightly darker than preceding coat unless otherwise approved.
- D. Sand wood and metal surfaces lightly between coats to achieve required finish.
- E. Vacuum clean surfaces of loose particles. Use tack cloth to remove dust and particles just prior to applying next coat.
- F. Prime concealed surfaces of interior and exterior woodwork with primer paint.

### **09900.3.07 FINISHING MECHANICAL AND ELECTRICAL EQUIPMENT**

- A. Paint shop primed equipment.
- B. Remove unfinished louvers, grilles, covers, and access panels on mechanical and electrical components and paint separately.
- C. Prime and paint insulated and exposed pipes, conduit, boxes, insulated and exposed ducts, hangers, brackets, collars and supports, and except where items are shop finished.
- D. Paint exposed conduit and electrical equipment occurring in finished areas.
- E. Paint both sides and edges of plywood backboards for electrical and telephone equipment before installing equipment.
- F. Color code equipment, piping, conduit, and exposed ductwork in accordance with requirements indicated and color schedule. Provide flow arrows, and substance names.
- G. Reinstall electrical cover plates, hardware, light fixture trim, escutcheons, and fittings removed prior to finishing.

### **09900.3.08 SCHEDULE - EXTERIOR SURFACES**

- A. Wood - Primed Only: Application: for wood fascias, and other wood surfaces to be capped or otherwise protected.
  - 1. One (1) coat A-100 Alkyd Wood Primer Y24, WK
- B. Wood - Painted; Application: wood surfaces to be primed and top coated.
  - 1. One (1) coat A-100 Alkyd Wood Primer.
  - 2. Two (2) coats A-100 Latex Satin House & Trim A-82.

- C. Concrete Masonry; Application; concrete masonry located above grade.
  - 1. One (1) coat Heavy-duty filler, B42 W46, 10 mils DFT/coat. Color: white.
  - 2. Two (2) coats Metalatex Semi-Gloss Acrylic B42 series, 1.5 DFT/coat.
  
- D. Precast Concrete Structures Exteriors, Non-exposed Aluminum and Pump and Lift Station Wetwell Piping; Application; precast concrete installed below grade and non-exposed aluminum placed against concrete surfaces and pump and lift station wet well piping (except for flange bolts and stainless steel pump "slide-rail" system).
  - 1. One (1) coat of "Hi-Mil SHER-TAR" B69 B40/B60 V40, coal tar epoxy, 16-24 mils DFT/coat.
  - 2. Color: Black.
  
- E. Bare Steel; Application; unprimed bare steel.
  - 1. One (1) coat Kern Kromik Universal Metal Primer B50 Z Series, 3.0 mils DFT/coat.
  - 2. Two (2) coats of Industrial Enamel B54 Z Series, 2.0 mils DFT/coat.
  
- F. Steel - Shop Primed: Application; factory primed, site finished exterior metals.
  - 1. Primer touch-up: One (1) coat Kem Kromik Metal Primer, 3.0 mils DFT/coat.
  - 2. Top Coat: Two (2) coats of Industrial Enamel B54 Series, 2.0 mils DFT/coat.
  
- G. Steel - Galvanized: Application; Exterior galvanized metals (Except for chain link fence).
  - 1. One (1) coat "Galvite" B50 WZ30 paint, 2.0 mils DFT/coat.
  - 2. Two (2) coats of Industrial Enamel, B54 Series, 2.0 mils DFT/coat.
  
- H. Precast Concrete Pump Station/ Lift Station Wet Well Interior Epoxy Coating:
  - 1. See Section 11306.
  
- I. Aluminum fabrications, angles "I" beams etc., to be in contact with concrete surfaces:
  - 1. One (1) coat of "Hi-Mil SHER-TAR" B69 B40/B60 V40, coal tar epoxy, 16-24 mils DFT/coat.
  - 2. Color: Black

**09900.3.09 SCHEDULE - INTERIOR SURFACES**

- A. Wood - Painted; Application: wood surfaces to be primed and top coated.
  - 1. One (1) coat Wall & Wood Primer B49 WZ1.
  - 2. Two (2) coats ProMar 200 Alkyd Semi-Gloss Enamel B34 WZ 1101.

- B. Drywall - Painted; Application: Interior room drywall surfaces.
  - 1. One (1) coat ProMar 200 Latex Wall Primer B28 W200.
  - 2. Two (2) coats ProMar 200 Alkyd Semi-Gloss Enamel B34 WZ 1101
  
- C. Concrete Masonry; Application; interior concrete masonry wall surfaces located above grade.
  - 1. One (1) coat Heavy Duty Filler B42 W46, 10 mils DFT/coat. Color: white.
  - 2. Two (2) coats Metalatex Semi-Gloss Acrylic B42 series, 1.5 DFT/coat.
  
- D. Bare Steel; Application; interior unprimed bare steel.
  - 1. One (1) coat Kem Kromik Universal Metal Primer B50 Z Series, 3.0 mils DFT/coat.
  - 2. Two (2) coats of Industrial Enamel B54 Z Series, 2.0 mils DFT/coat.
  
- E. Steel - Shop Primed: Application; interior factory primed, site finished exterior metals.
  - 1. Primer touch-up: One (1) coat Kem Kromik Universal Metal Primer B50 Z Series, 3.0 mils DFT/coat.
  - 2. Top Coat: Two (2) coats of Industrial Enamel B54 Z Series, 2.0 mils DFT/coat.
  
- F. Concrete Floors: Application: Interior floors of buildings.
  - 1. One (1) coat of Concrete and Terrazzo Sealer.
  - 2. Two (2) coats of Industrial Enamel B54 Z Series, 2.0 rails, DFT/coat.
  
- G. Aluminum fabrications, angles "I" beams etc., to be in contact with concrete surfaces:
  - 1. One (1) coat of "Hi-Mil SHER-TAR" B69 B40/B60 V40, coal tar epoxy, 16-24 mils DFT/coat.
  - 2. Color: Black.

**09900.3.10 PROCESS PIPE, EQUIPMENT, AND VALVE IDENTIFICATION SCHEDULE OF COLORS**

- A. All visible pipelines shall be color coded in accordance with the Piping Identification Schedule with the exception of flexible connectors, flexible tubing, and aluminum, brass, bronze, stainless steel, copper, and fiberglass pipe and piping specialties. Painted process piping shall be identified by stenciling the process designation and direction of flow. Unpainted process piping shall be identified with its process designation and direction of flow using semi-rigid, snap-on acrylic plastic identification markers, or self-sticking type. Stenciling and markers shall be located at 10-foot intervals, at each change of direction, at each valve and piece of equipment, and adjacent to each point it passes through a wall, floor or ceiling. Comply with applicable requirements of ANSI A13.1 and OSHA 1910.144.

- B. Arrows indicating the direction of flow shall point away from the lettering. Label legends on the piping at the horizontal or vertical centerlines. Place letterings below the horizontal centerline where pipelines are too close together or where located above normal line of vision (or above the centerline when pipeline is below the normal line of vision). Letter sizes and band widths are given in the schedule below:

<u>Outside Diameter of Pipe Covering</u>	<u>Height of Letters</u>	<u>Width of Color Band</u>
¾ to 1¼ inch	½ inch	4 inch
1½ to 2 inch	¾ inch	8 inch
2½ to 6 inch	1¼ inch	12 inch
8 to 10 inch	2½ inch	24 inch
Over 10 inch	3½ inch	32 inch

- C. Equipment and Valve Identification: Paint process equipment and valves the same color as their respective piping systems. Comply with applicable requirements of ANSI A13.1, OSHA 1910.144, and Ten States Standards. Identify process equipment and valves as indicated on the Drawings.

- D. All exposed pipes/conduit and other specified facilities in the various systems shall be color coded, and otherwise identified, as follows:

1. Pipes\*:

- a. **Natural gas line:** orange or red with black bands
- b. **Non-potable water line:** blue with black bands
- c. **Treated Water:** dark blue with arrow and symbol TW
- d. **Potable water line:** blue with arrow and symbol PW
- e. **Chlorine water line:** yellow
- f. **Wastewater line:** gray
- g. **Compressed or blower air:** green with arrow and symbol CA

\*The contents and direction of flow shall be stenciled on the piping in a contrasting color, in a lettering size visible at least ten feet away.

2. Pump Station Building Interior Color Schedule Guidelines:

- a. Walls: Mill White
- b. Ceilings: Mill White
- c. Floor: Gray
- d. Steel Doors: Site Brown
- e. Door and Window Frames: Site Brown
- f. Pumps: Electronic Beige
- g. Motors: Electronic Beige
- h. Electrical Conduit: Mill White
- i. Plumbing Vent Piping: Mill White
- j. Ductwork: Mill White
- k. Equipment Lift: OSHA Safety Green

3. Pump Station Building Exterior Color Schedule Guidelines:
  - a. Steel Doors: Site Brown
  - b. Steel Lintels: Site Brown
  - c. Miscellaneous Metals: Site Brown
  - d. Bollards: Safety Yellow
  - e. Louvers: Duranodic 312 (or approved equal) Medium Bronze
  - f. Light Fixtures: Duranodic 312 (or approved equal) Medium Bronze
  - g. Building Lettering: Duranodic 312 (or approved equal) Medium Bronze
  - h. Rain Gutter: Site Brown
  
4. Wet Well and Valve Vault Color Schedule Guidelines:
  - a. Interior Valve Chamber: White
  - b. Interior Wet Well: White
  - c. Exterior Valve Chamber: OSHA Safety Green
  - d. Exterior Wet Well: OSHA Safety Green

This color schedule is for guidance only. A color chart must be submitted to the AUTHORITY to confirm colors to be selected for specific pump station project site.

**END OF SECTION**

## **SECTION 11306 SEWAGE PUMPING STATION**

### **PART 1 – GENERAL**

#### **11306.1.01 SUMMARY**

A. Section Includes:

1. CONTRACTOR shall furnish all materials, labor and equipment necessary to install a wet well-valve chamber style sewage pumping station with submersible pumps as shown on the Drawings and as hereinafter specified. Refer to the Standard Details S-15, S-16 and S-17 relative to a typical pump station site plan and cross-section views.
2. The sewage pumping station structure shall consist of a precast reinforced concrete wet well (circular) and a precast reinforced concrete valve chamber (rectangular). The principal items of equipment in the wet well shall include, but not necessarily be limited to:
  - Two (2) submersible non-clog sewage pumps (with identical spare pump).
  - Stainless steel guide rails.
  - Stainless steel guide rail anchor brackets.
  - Stainless steel lifting chains.
  - Hydraulically sealed discharge flanges.
  - Hydraulic sewage grinder with stainless steel guide rails and accessories.
    - A stainless steel strainer basket with stainless steel slide rails may be provided in lieu of sewage grinder under certain circumstances, if approved by OWNER.
  - Liquid level controls including radar as primary, level sensing probe as backup, high-high float, and operating controls.
  - Stainless steel portable hoist assembly.
  - Vents and access hatches.
  - Generally speaking, all components and hardware installed inside the wet well shall be of stainless steel construction.
3. The principal items of equipment in the valve chamber shall include, but not necessarily be limited to:
  - All required valves including isolation gate valves, check valves with swing arms and air release (if necessary).
  - Flow meter and display.
  - Piping, flushing/quick connect tee, vents, and access hatch.

- Drain to wet well.
  - Sump for future sump pump with discharge valves and piping extended from valve chamber to the wet well.
  - Provide two (2) spare conduits from the Control Building to the valve chamber.
4. Other related principal items at the pump station site shall include, but not necessarily be limited to:
- An electrical/generator Control Building to house pump controls and other electrical components in wall mounted stainless steel NEMA 12 enclosures.
  - Diesel powered emergency generator with skid mounted double wall diesel fuel storage tank.
  - Communications system for SCADA. To be coordinated through BCWSA's SCADA Consultant and to be approved by the AUTHORITY.
  - Wireless IP Camera(s) with local/remote DVR, power, and pole(s) for mounting camera(s). Manufacturer/supplier to be coordinated through BCWSA's Security Consultant and to be approved by the AUTHORITY.
  - Potable water supply and yard hydrant.
  - All necessary interior and exterior lighting.
  - Fencing and driveway with parking area.
  - All associated utilities, wiring, and appurtenances as specified in this and related sections, and/or as shown schematically on the Standard Details and Drawings.
5. Special Requirements for the Pump Station:
- Any Developer installing a pump station to serve a development, where the pump station is to be dedicated to BCWSA, shall create and provide a physical address for the pump station site that BCWSA can use for future dealings with energy and communication companies. This is regardless of whether the pump station is located on its own parcel or if it is located on an easement to be conveyed to BCWSA as part of the dedication process. This is to be a "911 dedicated address", and this must match the address that the energy company lists on its bill for the pump station.
  - A high speed fiber optic service is to be provided to the pump station building. This service is to be through Xfinity/Comcast, unless directed otherwise.
  - Two 3" diameter conduits are to be provided from the utility pole (or source of fiber optic service) to the pump station control building, one labeled Primary Data and the other labeled Spare Data.
6. This Specification Section covers a wet well-valve chamber style pumping station using submersible pumps. There may be circumstances where a wet well-dry well style pumping station is more appropriate in which case the AUTHORITY should be consulted prior to design.

## **11306.1.02 RELATED INFORMATION**

### **A. Related Work specified elsewhere:**

1. Section 02220 - Excavation, Backfill and Compaction
2. Section 02229 - Rock Removal
3. Section 02510 - Paving Restoration
4. Section 02610 - Utility Pipe and Fittings
5. Section 02650 – Water and Sanitary Sewer System Testing
6. Section 02832 - Chain Link Fence and Gates
7. Section 02905 - Landscaping
8. Section 03302 - Concrete Work for Utilities
9. Section 09900 - Painting

### **B. Associated Construction Details:**

1. S-15 – Typical Pump Station Layout Sketch
2. S-16 – Typical Pump Station Plan View and Notes
3. S-17 – Typical Pump Station Section View
4. S-18 – Typical Sewage Grinder Channel Frame and Rail System

## **11306.1.03 QUALITY ASSURANCE**

### **A. Reference Standards:**

1. American National Standards Institute (ANSI):
  - A21.4 - Cement-Mortar Lining for Cast-Iron and Ductile-Iron Pipe and Fittings.
  - A21.10 - Gray-Iron and Ductile-Iron Fittings 3-inch through 48-inches
  - A21.15 - Flanged Ductile-Iron and Gray-Iron Pipe with Threaded Flanges
  - A21.51 - Ductile-Iron Pipe, Centrifugally Cast in Metal Molds or Sand-Lined Molds, for Water or Other Liquids
  - B16.21 - Non-metallic Flat Gaskets for Pipe Flanges
  - B18.2.1 - Square and Hex Bolts and Screws Inch Series Including Hex Cap Screws and Lag Screws
  - B18.2.2 - Square and Hex Nuts (Inch Series)
2. American Society for Testing and Materials (ASTM):
  - C478 - Specification for Precast Reinforced Concrete Manhole Sections.
  - C923 - Specification for Resilient Connections between Reinforced Concrete Manhole Structures and Pipes

Federal Specification: SS-S-00210 Joint Sealant Compound

National Fire Protection Association: National Electric Code

PA Department of Transportation: Publication 408 Specifications

B. Experience:

1. The manufacturer of the sewage pumping station specified herein shall have had equipment of this type in actual service for a period of not less than ten (10) years.
2. The manufacturer shall upon request include, with the required submittal, a list of similar installations including the date placed in operation, unit description and name and phone number of a contact person.

C. Factory Inspection and Testing:

1. Prior to assembly, all station components shall be inspected for quality and tested for proper function and freedom from defects.
2. The pump manufacturer shall perform the following factory inspections and tests on each pump.
  - a. A check of the voltage and frequency shall be made as shown on the name plate.
  - b. A motor and cable insulation test for moisture content or insulation defects shall be made.
  - c. The pump shall be completely submerged and run to determine that the unit meets three predetermined performance points plus design point.
  - d. A vibration test shall be run on each unit at maximum RPM with maximum velocity values not to exceed 1.0 mils peak-to-peak.
  - e. A written report shall be provided showing the aforementioned tests have been performed and shall include the system curve, static head, minimum pumping efficiency, motor speed and horsepower, power requirements, and pump discharge size.

D. Acceptable Manufacturer of Pumps and Controls:

1. Pumps shall be Flygt as manufactured by Xylem. Substitutions in accordance with Section 01010, Paragraph 1.05.
2. Pump Controls will be combined with the SCADA Panel into one unit, to be coordinated through BCWSA's SCADA Consultant. The combined Pump Control/SCADA Panel will be built to meet BCWSA current standards.

## 11306.1.04 SUBMITTALS

- A. Submit to the AUTHORITY for approval in accordance with Section 01010, Paragraph 3.04, the complete construction drawings, structural calculations, specifications, and hydraulic computations for the pumping station, including emergency generator and all appurtenances. All drawings, specifications, and hydraulic computations shall be prepared, signed, and sealed by a Professional Engineer registered in the Commonwealth of Pennsylvania. Drawings shall incorporate structural, mechanical, civil, and electrical details for all associated structures, site construction, and landscaping as specified in other sections. Electrical drawings and specifications shall be prepared, signed, and sealed by a Professional Engineer registered in the Commonwealth of Pennsylvania.

No construction work shall commence until all plans have been reviewed and all items addressed in the review(s) have been resolved.

B. Shop Drawings:

1. Complete design calculations computing discharge capacity, system head curve, wet well volumes, float elevations, and anti-flotation requirements. Flotation calculations shall include a safety factor of 1.2 based on assumed groundwater to finished grade and not include the weight of backfill, pumps, or appurtenances.
2. Complete construction plans including pump station site plan, pump station section view, mechanical plan, and electrical plan. Plans shall include elevations, pipe sizes and fittings, structure and mechanical dimensions, electrical equipment layout, conduit and wire sizing, and all other details as required by the ENGINEER.
3. Submit detailed shop drawings including dimensional drawings, descriptive literature, and wiring diagrams by the equipment manufacturer(s) for the following items: precast reinforced concrete wet well; precast reinforced concrete valve chamber; aluminum access hatches for wet well and valve chamber; resilient connection seal(s); joint sealant compound; coatings; submersible pumps; breakaway fittings; guide rails; sewage grinder, strainer basket and slide rail system; liquid level controls; portable hoist assembly and sockets, including layout and dimensions that show pump, access hatch, and crane clearances; junction boxes; check valves; gate valves; flow meter; ductile iron pipe and fittings; SCADA components, automatic telephone dialer; and pump and controls system as further described below.
4. Pump Characteristic Curves: Submit copies of the pump performance curves for review and approval. Curves shall show head, horsepower and efficiency versus capacity and NPSH. Drawings and curves shall be complete and shall show all information needed to demonstrate that the pumps to be furnished are in accordance with the conditions specified. Standard submittals shall consist of, but not be limited to, Pump Outline Drawing, Control Data and Schematic, Installation Guides, Technical Manuals and Parts lists.
5. Certified Pump Test Curves: CONTRACTOR shall submit for approval by ENGINEER, prior to shipment of pumps, certified pump test curves for each pump to be furnished. The pump test curves shall be certified by a Registered Professional Engineer. The test

curves shall show head versus capacity, horsepower versus capacity and pump efficiency as recorded at the manufacturer's test facility.

6. Operation and Maintenance Instructions. CONTRACTOR shall furnish AUTHORITY with four (4) copies of complete operation and maintenance instructions in accordance with Section 01010, Paragraph 3.18. It shall include a detailed description of operation of each principal component, procedures for operation, instructions for overhaul and maintenance, lubrication schedule, safety precautions, test procedures, and parts list. The O&M Manual shall also include cut sheets of the major components provided, including the pump curves, model numbers, dimensions, line diagrams, etc.
7. For VFDs and motors, submit outline drawings, including top, side and front views, catalog cuts, wiring and interconnection diagrams, system operation descriptions, certification of compatibility, and operation and maintenance manuals. Include manufacturer's recommended instructions and field testing procedures. Submissions shall include size and weight of equipment and location of all connections. It shall also indicate the system power factor at full speed, low speed, and three intermediate speeds. Calculations shall be provided as part of the submission.
8. The Vendor shall submit shop drawings of the control system. Submission shall include, but not be limited to, elementary diagrams, wiring diagrams, flow diagrams, nameplate listing, cuts of components including remote sensor and interface equipment, layout of enclosure and control panel, description of operation, block diagram indicating field wiring and installation instructions.
9. Provide separate control diagram with each line numbered and relay contacts indicated and written description of control sequence.
10. Submit Manufacturer's Installation Certificate in accordance with Section 11306.3.04.E.

#### **11306.1.05 MAINTENANCE MATERIALS**

- A. Provided one (1) complete set of the manufacturers' recommended spare parts, to include a minimum of the following:
  1. 100% spare fuses.
  2. 100% spare pilot light and alarm light lamps.
  3. One (1) complete spare pump, including motor, internal sensors, and cables, identical to pumps installed, with certified test pump curve.
  4. One (1) spare motor starter coil
  5. One (1) spare control transformer.
  6. Two (2) general purpose relays for control panel.
- B. Package each part individually or in sets inside moisture-proof containers or wrappings, clearly labeled with part name and manufacturer's part/stock number. Provide any special tools required for equipment maintenance.

### **11306.1.06 FIELD SERVICES**

- A. Provide the services of a manufacturer's representative experienced in the installation and operation of the pumping station supplied under this specification for not less than one 8-hour workday onsite for installation inspection, start-up and performance testing, and instructing AUTHORITY's operating personnel.

### **11306.1.07 WARRANTY**

- A. For a period of 24 months from the date of shipment or 18 months from start-up, whichever occurs first, the equipment manufacturer shall warrant that the equipment and controls covered by these Specifications shall be free from defects in material and workmanship under normal use and service. The manufacturer shall agree to repair or replace F.O.B. point of shipment such equipment or controls, or any part thereof, previously furnished by them which is found to be defective during the warranty period.

## **PART 2 - PRODUCTS**

### **11306.2.01 WET WELL**

- A. Structure:
1. The wet well shall be a circular precast concrete structure with a monolithically poured base and riser section(s). The unit shall have a minimum 12" monolithic bottom with anti-flotation collar (if required by floatation calculations), be 4,000 PSI reinforced concrete, and shall conform in all other aspects to ASTM C478. Minimum inside diameter shall be 6'-0" (actual diameter to be sized according to the capacity of the pump station). Maximum free fall to the "Pump Off" level shall be five (5) feet.
  2. All joints shall be sealed with Ram-Nec sealant, or approved equal.
  3. The top cover slab shall be a minimum 8" thick concrete slab designed to support H-20 loading, with:
    - a. Integral cast aluminum pump access hatch with safety platform.
    - b. Integral cast aluminum sewage grinder/strainer basket hatch.
    - c. A 4" stainless steel vent with insect screen. The vent shall have a confined space warning sign attached with stainless steel U-bolts.
    - d. Mounting sockets shall be "Floor Type" and bolted to the top slab to accept a portable hoist. A drain hole shall be provided in the bottom of each socket and underlying concrete slab, to prevent damage from freezing. The drain shall not discharge into the wet well.
  4. The station shall also be equipped with an inlet gasket, 1.5" stainless steel guide rails (or larger as required by pump manufacturer), and a stainless steel level control switch-mounting bracket with a compression grommet that allows for level setting adjustment.

B. Coatings:

1. Interior: A white epoxy coating shall be applied to the entire interior concrete surface of the wet well. The coating shall consist of two (2) coats, each six (6) mils thick, of Penn-Chem Coating #54-W-23, by MAB Coatings; Epoxide 34, ceramic white, by Sherwin Williams; or approved equal, applied as recommended by the manufacturer under controlled conditions at concrete manufacturer's plant.
2. Precast concrete exterior installed below grade and non-exposed aluminum placed against concrete surfaces
  - a. Two (2) coats of coal tar epoxy: Ply–Tile Epoxy Tar, by MAB Coatings; “Hi-Mil SHER-TAR”, by Sherwin Williams; or approved equal. Apply 8-10 mils DFT/coat. Color: Black.
  - b. If exterior coating is to be factory applied, it shall be done only after concrete is fully cured. Otherwise, field apply exterior coating not earlier than 30 days after date of manufacture.
3. Coatings for all internal piping and fittings within wet well shall be as follows:
  - a. SP-10 near white blast with shop primer coat of 650 Ply-Mastic (polyamide polyamine epoxy) 3-5 mils DFT (MAB).
  - b. Field touch up with 650 Ply-Mastic (MAB) 3-5 mils DFT, followed by two coats of 650 Ply-Mastic at 4-6 mils DFT per coat. Provide color break between coats.
  - c. See Section 09900 for painting of pipes.

C. Aluminum Access Hatches:

1. Aluminum, flush frame type. Provide a double leaf and single leaf hatch for the pump station as recommended by the pump station manufacturer for pump and sewage grinder/trash basket removal. Pump station access hatch shall open so as not to interfere with the operation of the portable hoist assembly during pump or grinder/trash basket lift-out. Provide a protective grating panel. Grating shall be hinged, sized to match each hatch leaf size, and shall be supplied with a positive latch to maintain unit in an upright position. Grating support ledges on 300 lbs./sq. ft. loaded access covers only shall incorporate nut rail with a minimum of four (4) stainless steel spring nuts. A padlock hasp for a padlock shall be provided.
2. Provide each hatch with minimum ¼” thick diamond checkered aluminum plate cover designed for minimum H-20 loading. Furnish hatch with stainless steel hinges, stainless steel hinge pins, spring-operated lifting mechanism, automatic hold-open arm with release handle, stainless steel inside snap lock, and removable key-wrench lifting handle. Mill finish with bituminous coating applied to exterior of this frame.
3. Provide access hatch with drain, and 1-1/2” channel drain pipe discharging to ground. Channel drain piping shall be black steel with malleable iron fittings.

4. Access Hatches shall be Halliday Products, Series H1C (single leaf) & H2C (double leaf), or other approved equal. Protective grating panel shall be as manufactured by Halliday, or approved equal.

D. Sewage Grinder (Comminutor):

1. Provide one dual shaft sewage grinder unit capable of continuous operation, processing wet or dry, through flow ranges of from 0 gpm to the peak design flow of the sewage pump station. The grinding unit should be a removable unit mounted on slide rails within the sewage pumping station wet well. Slide rail system and mounting shall be constructed of stainless steel.
2. Each grinder shall include cutters, spacers, shafts, bearings and seals, side rails, end housings, covers, reducer, and motor. The shafts shall consist of two parallel shafts alternately stacked with individual intermeshing cutters and spacers positioned on the shaft to form a helical pattern. The side frames shall be slotted to give improved hydraulic performance and flow capacity while still maintaining the grinding fineness.
3. The grinder motor shall be a low-speed, high-torque, rotary-power hydraulic torque motor that utilizes the hydraulic pressure developed by the hydraulic power pack. The hydraulic power pack shall be rain-resistant and suitable for mounting in a remote location; however, the hydraulic power pack shall be installed on a pad inside the control building. Hydraulic connections between the torque motor (in wet well) and the power pack shall consist of two 1/2 inch (min.) flexible hoses with quick disconnects, and hoses to be installed within a watertight carrier conduit placed underground between wet well and control building (sealed to prevent gases from wet well entering the Control Building). The hydraulic power pack shall be filled with a high quality hydraulic fluid by CONTRACTOR.
4. The Motor Controller shall also be housed in the Control Building inside a NEMA 4X enclosure, and shall have switches, indicator lights, and other control devices. Controller shall be designed to suit the supply power and motor characteristics for the project, and shall be Model PC2240 as manufactured by JWC Environmental, LLC, or approved equal.
5. The grinder motor controller shall include auto load sensing to reverse the grinder automatically to clear obstructions. Up to three (3) reversing cycles may occur within 30 seconds before the controller de-energizes the grinder motor and activates the grinder fail indicator and relay. Control panel shall be enclosed in a NEMA 4X enclosure and shall be equipped with a control power transformer, reversing contactors, overload relays, circuit breaker, three (3) position selector switch, indicator lights, and signal relay outputs.
6. All controls and accessories shall be of the manufacturer's model and type specified and approved by the AUTHORITY. Sewage grinder shall be a Muffin Monster® Model 30000 (Wipes Ready, Open Channel Style) by JWC Environmental, or approved equal.
7. A stainless steel strainer basket and lift cable shall be provided for use when comminutor is not in service.

E. Pipe Penetration Seal:

1. The annular opening between each pump discharge line and the wall sleeve shall be sealed with a sealing device specifically manufactured for wall pipe penetrations and rated to withstand the maximum external hydrostatic pressure which could occur.
2. The sealing device shall be X-Cel gaskets, as manufactured by A-Lok Products, Inc. of Tullytown, Pennsylvania, or approved equal. For pipe penetrations made in the field, the seal shall be made using Link-Seal as manufactured by Thunderline Corporation, or approved equal.

F. Coarse Aggregate:

1. PennDOT No. 2A or AASHTO No. 8 in accordance with Table C, Section 703.2, Publication 408 Specifications.

G. Concrete:

1. See Section 03302.

**11306.2.02 VALVE CHAMBER**

A. Structure: Rectangular Precast Concrete. Minimum inside dimensions shall be 8'-0" wide by 7'-0" long, or larger if required by the project conditions. Inside headroom clearance shall be 7'-6" minimum and 8'-0" maximum, unless otherwise approved/required by the ENGINEER. Provide anti-flotation collar as required by flotation calculations.

B. Coatings:

1. Interior: All surfaces shall receive two (2) coats of TNEMEC Series 66 Hi-Build Epoxoline, 5 mil DFT each coat, or approved equal. Minimum total dry film thickness shall be 10 mils. Color to be Beige.
2. Precast concrete installed below grade and non-exposed aluminum placed against concrete surfaces.
  - a. Two (2) coats of coal tar epoxy: Ply-Tile Epoxy Tar, by MAB Coatings; "Hi-Mil SHER-TAR", by Sherwin Williams; or approved equal. Apply 8-10 mils DFT/coat. Color: Black.
  - b. If exterior coating is to be factory applied, it shall be done only after concrete is fully cured. Otherwise field apply exterior coating not earlier than 30 days after date of manufacture.
3. Coatings for all internal piping and valves within the valve chamber shall be as follows:
  - a. SP-10 near white blast with shop primer coat of 650 Ply-Mastic (polyamide polyamine epoxy) 3-5 mils DFT (MAB).

- b. Field touch up with 650 Ply-Mastic (MAB) 3-5 mils DFT, followed by two coats of 650 Ply-Mastic at 4-6 mils DFT per coat. Provide color break between coats.
- c. See Section 09900 for painting of pipes.

C. Aluminum Access Hatches:

1. Provide a double leaf hatch for the valve pit sized to give clearance above the discharge valves and bypass line (minimum opening to be 48"x 48"). Valve pit hatch shall have 1" channel frame with anchoring flange.
2. Provide hatch with minimum ¼" thick diamond checkered aluminum plate cover designed for minimum H-20 loading. Furnish hatch with stainless steel hinges, stainless steel hinge pins, spring-operated lifting mechanism, automatic hold-open arm with release handle, stainless steel inside snap lock, and removable key-wrench lifting handle. Mill finish with bituminous coating applied to exterior of this frame.
3. Provide access hatch with drain, and drain to be daylighted to exterior of the precast concrete vault (not to drain into vault). Provide 1-1/2" channel drain pipe discharging to ground. Channel drain piping shall be black steel with malleable iron fittings.
4. Access Hatches shall be Halliday Products, Series H2C (double leaf), or approved equal.

D. Pipe Penetration Seal:

1. The annular opening between each pump discharge line and the wall sleeve shall be sealed with a sealing device specifically manufactured for wall pipe penetrations and rated to withstand the maximum external hydrostatic pressure which could occur.
2. The sealing device shall be X-Cel gaskets, as manufactured by A-Lok Products, Inc. of Tullytown, Pennsylvania, or approved equal. For pipe penetrations made in the field, the seal shall be made using Link-Seal as manufactured by Thunderline Corporation, or approved equal...

E. Ladder:

1. A vertical aluminum ladder with a minimum width of 16 inches shall be provided, supported 7 inches from the wall with brackets spaced at maximum 5 feet on center. The ladder shall be capable of being fastened to the concrete valve chamber using stainless steel anchor/expansion bolts, and shall be as manufactured by Halliday, or approved equal. Ladder rails shall be constructed of 2½" x 3/8" aluminum flat bar with 1-3/8" diameter non-slip ribbed rungs welded to the rails and spaced at 12 inches on center.
2. The aluminum ladder shall conform to the requirements of the Occupational Safety and Health Standards, U.S. Department of Labor (29 CFR 1910.27).
3. Provide aluminum grab bar mounted to top of valve vault lid (exterior) to assist in entering and existing the vault. In lieu of grab bar, ENGINEER will consider extendable hand bars attached to the ladder.

F. Coarse Aggregate:

1. PennDOT No. 2A or AASHTO No. 8 in accordance with Table C, Section 703.2, Publication 408 Specifications.

G. Concrete:

1. See Section 03302.

**11306.2.03 RAW SEWAGE PUMPS AND APPURTENANCES**

A. Acceptable Manufacturers (Pumps)

1. Xylem Flygt (Type "N" impeller). Substitutions in accordance with Section 01010, Paragraph 1.05.

B. General Scope: Two (2) field serviceable, submersible, heavy duty, non-clog "explosion-proof" sewage pumps shall be provided, each rated for the capacity (GPM) and total dynamic head (feet) associated with the project based on case specific calculations. Grinder pumps shall only be used with specific approval of the AUTHORITY. The operating point of the pump shall be adequate to provide the required design flow with minor total dynamic head changes. Pump efficiency shall be a major consideration in pump selection.

1. One (1) complete identical pump, including motor, shall be provided as a spare unit. The spare unit shall be furnished completely assembled and in all aspects identical to the installed pumps, including internal sensors and cables.

C. Pump Design:

1. The sewage pumps shall have a cast iron pump case and motor housing, integral stainless steel motor and pump shaft and stainless steel fasteners.
2. The pump shall be equipped with a cast iron impeller with back pressure vanes, statically and dynamically balanced. Impeller size at design point shall not exceed 90 percent of non-overloading full size impeller over the full range of operation. Capable of passing a 3" solid sphere.
3. Provide tandem carbon/ceramic mechanical shaft seals with oil chamber between seals. Mount an electrode between seals to detect water leaking into seal chamber and actuate a light on the control panel.
4. The pump shall be equipped with upper and lower ball bearings to support the rotor and a lower bronze sleeve or ball bearing to take radial loads from the impeller. Minimum ball bearing B-10 life of 15,000 hours.
5. The casing and impeller shall be fitted with removable and replaceable wear rings.
6. One pump (not the spare) in each pump station shall be fitted with a hydraulically operated flush valve to limit solids and grease buildups.

#### D. Pump Motors

1. The motor shall be listed with Underwriter's Laboratories as complying with National Electrical Code requirements for Class I, Division 1, Groups C and D locations, explosion-proof, for installation in raw sewage.
2. The pump motor shall be 1750 RPM (maximum). For grinder pumps, a speed of 3500 rpm will be permitted. In all cases the motor shall operate on three phase, 60 Hertz, 240 or 480 volt power. Motor horsepower shall be selected based on case specific design.
  - a. Maximum allowable horsepower for a submersible pump shall be 75 HP. Utilize a triplex (or more) pump station design as necessary to keep the horsepower of a single pump at or below 75 HP, with two pumps operating to meet the design peak flow, and the third pump as a backup.
  - b. If three phase cannot be provided, ENGINEER will consider allowing single phase with VFD's to convert pump supply to three phase.
3. NEMA Design B, Class F insulated, squirrel cage induction type, sealed submersible motor with open windings operating in dielectric oil and minimum 1.15 service factor. The motor shall be non-overloading through the entire range of the pump curve. Motor leads potted in epoxy compound to form leak-proof seal.
4. Protect motor with a heat sensor thermostat to stop motor if overloaded. Thermostat to reset automatically when temperature drops to a safe level.
5. All electric motors greater than ten (10) horsepower shall be provided with a variable frequency drive.
6. Motors applied with variable frequency drives (VFD's) shall be specifically manufactured and labeled for inverter duty. De-rating of a standard motor for inverter duty shall not be approved.

#### E. Break Away Fittings (BAF):

1. The break-away fitting shall be designed to allow the submersible pump to be installed or removed without requiring personnel to enter the wet well. The stationary portion of the BAF consists of a specially designed cast iron base elbow which is bolted to the floor of the wet well. The pump bolts to the cast iron moveable portion which is free to ride up and down the guide rails. An O-ring is pressed into a dove-tailed groove on the tapered face of the moveable fitting. The tapered faces of the moveable fitting and base elbow allow for a positive mating of the O-ring to base. This elastomer to cast iron contact assures a complete and positive seal which allows pumps to operate without hydraulic leakage, over a wide range of discharge pressures up to 150 PSI.
2. The guiderails shall be attached to the base elbow at one end and to a stainless steel guide cap which is attached to the underside of the wet well cover at the other end. Both the guide cap assembly and the base elbow shall have cast iron plugs with O-rings mounted in them which aid in locating the guiderails and in reducing noise and vibration of the

guide rails. The guiderails serve only to guide. They carry none of the pump weight. Stainless steel Schedule 40 pipe should be used for guiderails (min. diameter shall be 1.5", larger as recommended by pump manufacturer). A stainless steel intermediate guide pipe bracket should be used for depths of 10 feet or more.

F. Pump Accessories:

1. Each pump shall be furnished with a discharge elbow of the appropriate size, stainless steel upper guide bar bracket, stainless steel intermediate guide bar bracket(s), stainless steel safety hook and discharge connection accessories.

G. Testing:

1. Testing performed upon each pump shall include the following inspections:
  - a. Assure that piping and basin are clear of debris which might clog pump.
  - b. Check level switch settings.
  - c. Check for proper rotation.
2. Motor and cable insulation shall be tested for moisture content or insulation defects. Upon request, a written quality assurance record confirming the testing/inspections shall be supplied with each pump at the time of shipment. Capacity and kilowatt draw required. The witness of tests shall be available at the factory upon request.
3. Operate the pump station using clear water at the design point through two complete pumping cycles under the supervision of the manufacturer's representative and in the presence of the ENGINEER or AUTHORITY. Check pump and motor for excessive vibration and high bearing temperatures. Demonstrate correct sequence of pump operation. Check for motor overload by taking ampere readings.
4. Verify the pump performance by timing how long it takes to drawdown a specific volume of liquid and measuring the pump discharge head with a pressure gauge.
5. Demonstrate provision for pump removal and replacement.

H. Start-up Service:

The equipment manufacturer shall furnish the services of a qualified factory trained field service engineer at the site to inspect the installation and instruct the owner's personnel on the operation and maintenance of the pumping units. After the pumps have been completely installed and wired, the CONTRACTOR shall have the manufacturer do the following:

1. Check power cables
2. Check seal lubrication
3. Check for proper rotation
4. Check power supply voltage
5. Measure motor operating load and no load current
6. Check level control operation and sequence

During this initial inspection, the manufacturer's service representative shall review recommended operation and maintenance procedures with AUTHORITY personnel.

#### **11306.2.04 LIQUID LEVEL CONTROLS**

- A. Primary: Radar sensor mounted at top of the wet well in area easily accessible from ground level of the wet well, for continuous level measurement. Radar unit to be manufactured by Vega Americas, Inc. of Cincinnati, OH, (substitutions in accordance with Section 01010, Paragraph 1.05) with the following requirements:
1. Model: VEGAPULS C 21
  2. Order Code: RA - 222 396
  3. Wired radar sensor for continuous level measurement
  4. Axial cable outlet, measuring range up to 20 m, accuracy  $\pm 2$  mm
  5. Explosion protection FB : c-FM-us/c-CSA-us; Gas, encapsulation, Zone 1, 2 (Class I Division 2) + Dust, protection by enclosure, Zone 20, 20/21, 21, 22 (Class II, III Division 1)
  6. Approved as overfill protection X : without
  7. Ship approval X : without
  8. Foodstuff/Pharmaceutical certificate X : without
  9. Thread process side / Cable side N : Thread 1½ NPT / 1NPT
  10. Cable material / Length B : PUR / 10m (approx. 32ft) [confirm with each project]
  11. Electronics H : Two-wire 4 ... 20 mA/HART
  12. Bluetooth operation B : with
  13. Additional cleaning procedures : without
  14. Measurement loop identification : without
  15. Customs tariff number (HS code) : 90318080
- B. Backup: Provide integrated electronic level sensing system, including 10 stainless steel sensors in a molded PVC probe rod. Level sensor shall be a Flygt or MultiTrode probe. Substitutions in accordance with Section 01010, Paragraph 1.05. Probe length shall be selected based on depth of the wet well and the design pump start/stop set points.
1. Heavy neoprene-jacketed weighted cords shall be suspended from wiring channel. Level setting shall be adjustable from the top of pump station basin. Cable shall be supplied by manufacturer for the entire circuit, starting at the sensor and terminating in the pump control panel.
  3. A minimum of five switches are required; one for lead pump start, one for lag pump start, one for low-level pump stop, one for redundant low-level pump off, and one for high-level alarm.
- C. A manual switch shall select either Primary or Backup to control the pump station. Should the primary fail, an alarm shall be sent to the SCADA panel to alert BCWSA.
- D. Backup Floats: Provide three (3) mercury tube switches with intrinsically safe relays individually sealed in shock-resistant polypropylene floats.
1. The 1<sup>st</sup> float to be connected to the pump control panel, to act as a redundant high level

alarm.

2. The 2<sup>nd</sup> float to be connected directly to the alarm dialer for high level alarm.
3. The 3<sup>rd</sup> float to be connected to the pump control panel, to act as a redundant low level alarm. (Confirm with BCWSA if needed for a specific pump station design)

#### **11306.2.05 OPERATION OF LIQUID LEVEL CONTROLS**

- A. On initial rise of liquid level, the pump stop level is triggered. As liquid level increases, the lead pump level starts the lead pump. With lead pump running, basin liquid level decreases to the pump stop setting.
- B. When lead pump stops, an alternating relay indexes so that the lag pump will start on the next rise in liquid level. If any of the pumps continue to operate below the redundant pumps off switch, the switch will energize the low level alarm.
- C. If the liquid level continues to rise while the lead pump is running, the lag pump start level is triggered to start the lag pump. Both lead and lag pumps operate together until the pump stop level triggers both pumps to stop.
- D. If the liquid level continues to rise with both pumps in or out of operation, the high level float switch energizes the alarm signal, with one float sending the signal to the control panel and interconnected SCADA panel, and the second float sending the high alarm signal directly to the alarm dialer.

#### **11306.2.06 COMBINATION PUMP CONTROL/SCADA PANEL**

- A. Control panel shall be contained in a NEMA 12 enclosure, mounted on the interior wall of the Control Building at an easily accessible location. An H-O-A selector switch and green run lights shall be provided on the front of the panel for each pump. Red indicator lights with manual pushbutton reset shall be provided on the front of each panel for each alarm condition. Stainless steel nameplates shall be provided for all switches and lights.
- B. For constant speed pumps, the pump control system shall be furnished and provided as a combination Control/SCADA Panel. The OIT screen shall be a color touch screen.
  1. If a variable speed pump station is required, the pump control system will remain identical to the constant speed pump station type, except that variable frequency drives will be incorporated into the combination Control/SCADA Panel.
- C. Pump control unit shall be integrated with seal failure, thermistor and conductive probe level sensing from the pump station wet well. Controller interface shall provide status of the following on the main screen:
  1. Level
  2. Set points for pump start/stop
  3. High and low level set points
  4. Pump status: running/stopped

5. Pump available
  6. Pump fault
  7. Power status
- D. Control system shall include motor protection module for monitoring, logging, and alarm output for under current, over current, phase failure, ground fault, phase rotation, insulation resistance, three-phase station voltage, three-phase pump voltage, and three-phase current. Module shall allow measurement and logging of electrical usage.
- E. Control system shall include flow calculation, data logger and VFD control algorithm functions.
- F. Controls to incorporate the backup level rod into a backup level control, should the primary level control device fail. This shall require a manual switch to be toggled by the OWNER's personnel, upon receiving the alarm for the primary control's failure.
- G. Pump control panel shall be contained in a NEMA 12 enclosure. The pump control panel shall include the following:
1. Pump controller.
  2. Pump starters.
  3. Run indication light for each pump.
  4. Pump seal failure alarm light for each pump, with reset.
  5. Motor high temperature alarm light for each pump, with reset.
  6. High level alarm light.
  7. Elapsed time run meters (one for each pump).
  8. Dry alarm and telemetry contacts for high liquid level, low liquid level, motor high temperature (each pump), seal failure (each pump), motor starting failure (each pump), main power failure and relay for remote alarm monitoring.
  9. Phase loss protection with automatic reset (for all motors) with contact for telemetry.
  10. Circuit breakers for each motor and control circuit.
  11. Control transformers
  12. Touch Screen Panel, color, 15" or 22" size, TFT LCD, HD, LED backlight, two ethernet, three serial and four USB ports, one memory card slot. Manufactured by Automatic Direct, C-More CM5 Series. Substitutions in accordance with Section 01010, Paragraph 1.05.
- H. Moisture/seal sensors shall automatically stop the corresponding pump and energize the alarm circuit. Temperature sensors shall automatically stop the corresponding pump and energize the alarm circuit.

- I. Provide terminal strips in the control panel for all alarm circuits, controls, lighting and power wiring. Components shall be factory wired with fanning strips and straps to present a neat and workmanlike appearance. All wires shall be tagged. Fanning strips and terminal blocks shall be provided for all external connections, including those indicated for future. Wiring shall be color coded or be provided with tags, to be coordinated with the schematics and diagrams. All components shall be labeled and those which are on the surface of the equipment shall be provided with phenolic nameplates indicating the use and coordinate with the schematics and diagrams.
- J. No live electrical components shall be mounted on the panel door. Where necessary, access to the system components shall be only after interrupting power to the control system.
- K. All control circuits shall operate at 120 volts or less and shall be from fused circuits. Control transformers shall be included as required. All electrical sensing and control systems shall use low voltage contacts and intrinsically safe relays meeting the requirements of UL 913
- L. The control panel shall be provided with a separate protected circuit. Surge suppressors shall be provided to protect all components from lightning and switching surges.
- M. If VFD's are proposed for the pump station (for pumps of 10 HP or greater), they must include a bypass that allows the pumps to be operated across-the-line in automatic, should the VFD fail. VFD's are to be manufactured by Eaton Cutler Hammer, Model DG1. Substitutions in accordance with Section 01010, Paragraph 1.05.
- N. SCADA Component of Combination Panel
  - 1. CONTRACTOR shall provide a fully functioning communications system compatible with the AUTHORITY's most current SCADA/telemetry system.
  - 2. CONTRACTOR shall be responsible for AUTHORITY's costs incurred to integrate the sewage pumping station into the current SCADA/telemetry system, including cost of software revisions/upgrades.
  - 3. AUTHORITY will require the CONTRACTOR/DEVELOPER/Design Engineer to obtain the services of the AUTHORITY's SCADA System Vendor to ensure complete integration of communication system components into the AUTHORITY's SCADA system.
  - 4. Description of Components:
    - a. Provide a SCADA panel that will enable the pump station facility to be monitored and controlled from a remote location. The equipment models listed in this section are considered the standard at the time these Specifications were prepared; the OWNER reserves the right to require the latest equipment models recommended by their SCADA System Vendor at the time of the Project.
    - b. Provide access, egress, smoke and intrusion detection devices for the Control Building.

- c. Control panels shall be built by a registered UL 508 Industrial Control Panel builder. Each control panel shall bear a serialized "Enclosed Industrial Control Panel Label." Panels that utilize intrinsically safe barriers shall be upgraded from standard 508A to standard 698 and bear serialized label to that effect. The control panel submittal shall contain a copy of the front page of the control panel builders UL508A and 698 (if applicable) standard that shows their UL file number. The name on the front page of the UL Standard shall match the name in the title block of the control panel submittal.

5. SCADA Equipment

- a. The SCADA Remote Telemetry Unit (RTU) shall be a Schneider Electric SCADAPack 470/474 (Model TBUP474-UA50-BB00S) and shall include sufficient on-board digital inputs, digital outputs, analog inputs and outputs (see input/output list below). Combination Control/SCADA Panel to be coordinated through BCWSA’s SCADA Consultant. I/O Expansion Modules shall be Series 6607, Model TBUX297592S by Schneider Electric.
- b. The generic SCADA system Input/Output (I/O) List is as tabulated below, subject to change for particular pump station designs.

I/O Type	Quantity (min.)	Description(s)
Analog Inputs (AI)	8	Pump Station Force Main Flow Pump Station Wet Well Level VFD 1 Speed Reference (if VFD provided) VFD 2 Speed Reference (if VFD provided) Provide Spares
Analog Outputs (AO)	4	VFD 1 Speed Reference (if VFD provided) VFD 2 Speed Reference (if VFD provided) Provide Spares
Dry Contact Digital Inputs (DI)	24	Site Power Status Card Access Input Pump #1 Status Pump #2 Status Pump #3 Status (if 3 <sup>rd</sup> pump provided) Pump #4 Status (if 4 <sup>th</sup> pump provided) Pump #1 Auto Setting Pump #2 Auto Setting Pump #3 Auto Setting (if 3 <sup>rd</sup> pump provided) Pump #4 Auto Setting (if 4 <sup>th</sup> pump provided) Wet Well High Level Float Status PLC Status Generator/Control Building Intrusion Sensor Status Generator/Control Building Smoke Detection Generator Status Generator Fuel Low Remote/Local Operation Switch

I/O Type	Quantity (min.)	Description(s)
		Provide Spares
Dry Contact Digital Outputs (DO)	4	Pump #1 Run Pump #2 Run Pump #3 Run (if 3 <sup>rd</sup> pump provided) Pump #4 Run (if 4 <sup>th</sup> pump provided)

- c. Provide all accessories to ensure a complete and working system, including fuses, OIT cables, outlets, control relays, antenna, surge protector, data pockets, RS-232 cable, heater with thermostat, circuit breakers, lightning arrestor, RF cable, surge suppressors, fuse cover plates, fuse block cover plates, terminal blocks and cover plates, and fuse terminal blocks.

6. Access, Egress and Intrusion Detection Controls

- a. Proximity card reader and controller with corresponding magnetic type locks shall be installed at each entrance door to the Control Building. The magnetic lock will be activated by the proximity card reader unit such that the door lock will open when an authorized card is read. The card reader will also have a key pad that will be used by personnel to enter identification codes. A signal from the card reader shall be sent to the RTU, which will have the authorized codes stored in it locally. The RTU will transmit the code to the central control room. Proximity card reader unit and lock system shall be compatible with the SCADA system.
- b. Egress from the building during a power outage shall be accomplished using an emergency egress pushbutton that is installed at the doors to the building. The egress button, when depressed, will open the lock on its associated door.
- c. A door monitoring switch shall be installed on each door. In addition, passive infrared motion detectors shall be installed in each room of the building. The alarm contacts from each of these units shall be wired in series to provide one (1) input to the SCADA system.
- d. Install ceiling-mounted smoke detector where indicated on Drawings, and wire to the SCADA panel.

7. SCADA System Installation

- a. Fabrication, assembly, and delivery to the site shall be made only from approved submissions. The CONTRACTOR shall include all necessary wiring as detailed on the drawing.
- b. Before final instructions to the OWNER, field tests shall be conducted on the SCADA systems in conjunction with the ENGINEER to ensure that all operations are in agreement with the intent of these specifications. The CONTRACTOR shall furnish all labor and materials required for the field tests, and shall be

prepared to make additional tests and all corrections necessary at no additional cost to the OWNER.

- c. CONTRACTOR shall include calibration and start-up of each system with assistance of a factory-trained representative. CONTRACTOR shall coordinate times for instruction with OWNER and ENGINEER.

#### **11306.2.07 AUTOMATIC TELEPHONE DIALER**

##### **A. General Requirements:**

1. A separate protected circuit shall be provided for the dialer.
2. The dialer shall be packaged with the Combination Pump Control/SCADA Panel.
3. The dialer shall be a RACO "VERBATIM" series, VSS-16 as manufactured by RACO Manufacturing Inc. Substitutions in accordance with Section 01010, Paragraph 1.05.

##### **B. Description:**

1. The CONTRACTOR shall furnish, wire, install, and test a sixteen (16) point alarm dialer at the station, to be mounted as shown on the Drawings.
2. The alarm dialer shall be a RACO "VERBATIM" series, VSS-16 as manufactured by RACO Manufacturing Inc. with the following options: one (1) analog input, non-volatile memory, NEMA 4X enclosure, 8 channels, 20 hour battery backup, integral surge suppression and extended 5 year warranty.
3. The alarm dialer shall have a 20 button programming panel, voice microphone, and LED display screen.
4. The alarm dialer shall have built-in speech to support user programming, to provide warning messages and to provide default alarm or normal messages.
5. The dialer shall be capable of digitally storing actual spoken words inside its memory for use in dialed out alarm messages or statuses.
6. The alarm dialer shall contact the AUTHORITY personnel and list the status of the following alarms:
  - a. High Level Alarm
  - b. Pump Failure
  - c. Low Level Alarm
  - d. Power Failure
  - e. Generator Failure
  - f. Generator Run
  - g. Transfer Switch Failure
  - h. Dialer Power Failure
  - i. Intruder Alert

7. Electrical Protection: Transient voltage/surge protection shall be provided on power line, telephone and all input channels. Solid state surge protection provided on digital input, analog input, serial port, parallel port, telephone and AC power circuitry.
8. Wiring Protection: All input channels shall be completely isolated from each other and from ground. Analog and Digital Input channels shall be capable of withstanding continuous 120VAC without damage.
9. Field Wiring: All I/O wiring shall use quick-disconnect pluggable connectors.

#### **11306.2.08 PUMP STATION FLOW METER**

- A. A pump station metering system shall be installed to meter flows emanating from the pump station. The metering system shall be an electromagnetic flowmeter (explosion proof) with remote signal transmitter (displaying flow rate and totalizer) and chart recorder. The flowmeter shall be as manufactured by ABB Process Automation (WaterMaster) or Toshiba.
- B. The flow sensor liner shall have PTFE Teflon liner (minimum). The integrally-mounted flow sensor shall be FM approved for CSA Approved for Class I, Division 2. Sensor shall be submersible proof. The flow meter shall be warranted against defective workmanship or materials for a period of two years from date of acceptance. Flow meter shall provide raw wastewater flow measuring capabilities for the full range of the pumps with an accuracy of 0.4% (with ABB VeriMaster Fingerprint, or equivalent system). The flow meter manufacturer to provide two (2) stainless steel grounding rings. CONTRACTOR shall install per manufacturer's instructions. The remote surface mounting transmitter (converter) to be mounted in the Control Building, unless otherwise approved. CONTRACTOR shall pot the remote transmitter terminal box on the flow tube in the field, to ensure its integrity during submergence. CONTRACTOR shall seal all conduit ends after installation, to ensure no condensation enters any critical components. Provide one (1) additional outputs for flow alarm.
- C. Chart Recorder: A wall-mounted 10-inch circular, two (2) pen (each having a distinctive color) chart recorder having programmable chart rotation shall be located as indicated on the Drawings in the Control Building. Input signal shall be 4-20 mA, and capable of totalizing a flow signal. The recorder shall include two separate displays; one display will be for totalized flow, and the other will be able to display flow rate or total. All programming parameters shall be easily accessible via a keypad on the front of the recorder. Chart recorder shall be manufactured by Chessel (Model 392), ABB (Model 1300), or approved equal. The chart recorder shall have I/O capable for a SCADA analog input and spare. The recorder shall have a NEMA 4X enclosure with gasketed plastic window. The unit shall be UL approved. A two-year supply of pens and charts (based on a 7-day chart usage) shall be supplied as part of this work, along with an ordering form for additional pens and charts.
- D. The flow meter shall be installed in accordance with the manufacturer's recommendations inside the station valve chamber. A qualified manufacturer's representative, after the flow meter and chart recorder have been properly installed, shall calibrate the equipment with the OWNER's Personnel present and provide training as necessary.

## **11306.2.09 ELECTRICAL ENCLOSURES**

- A. All other required electrical equipment shall be mounted to the interior wall of the Control Building at accessible locations, inside NEMA enclosures when appropriate, including but not limited to:
1. Main disconnect switch
  2. Circuit breaker(s)
  3. Power Panel
  4. Lighting Panel
  5. GFI convenience outlet (120V)
  6. Temperature Controls
  7. Battery backup
  8. Ground, lightning and surge protection
- B. The electrical enclosures shall be as manufactured by Hoffman Engineering Company, or approved equal.
- C. Should any panel need to be placed outside, the outer enclosure shall have a thermostat-controlled exhaust fan. In addition, the panel shall be shaded from direct sunlight in a manner approved by the AUTHORITY and ENGINEER, such as an overhead lean-to style shelter.

## **11306.2.10 PIPING, VALVES AND SPECIALTIES**

- A. Interior Piping:
1. Flanged joint ductile iron pipe shall be Class 53 conforming to ANSI A21.15 / AWWA C115.
  2. Pipe shall be provided with double cement-mortar lining conforming to ANSI A21.4 / AWWA C104.
  3. Fittings shall be ductile iron or grey-iron flat faced with pressure rating of 250 psi conforming to ANSI A21.10 / AWWA C110 with ANSI B16.1 Class 125 flanges.
  4. Gaskets shall be full-faced, rubber and 1/8" thick conforming to ANSI B1621.
  5. All bolts and nuts used in the wetwell and valve chamber shall be 304 stainless steel.
- B. Exterior Discharge Piping:
1. See Section 02610.
- C. Check Valves:
1. Horizontal swing check type designed for use with raw sanitary sewage, with an external lever with an adjustable counter weight. An oil cushioned control feature may be necessary in certain cases of high static or dynamic head (to be provided as recommended by manufacturer and approved by ENGINEER).

2. The valve shall be of iron body construction with a stainless steel shaft incorporating bronze bushings, resilient seated, and renewable bronze disk seat rings, with ANSI B16.1 Class 125 flanges.
3. The check valve shall have a minimum working pressure of 175 psi and shall conform to the AWWA C508 Standard.
4. Valves shall be Model A-2600-6-01 as manufactured by Mueller Company, or approved equal.

D. Plug Valves:

1. Plug valve shall be flanged type, iron bodied, permanently lubricated, eccentric plug valves with full port (rectangular or round). Plug facing shall be resilient neoprene or Buna-N. Valves through 12" shall be rated for 175 psi working pressure. Valves larger than 12" shall be rated for 150 psi working pressure. Provide handwheel with arrow direction indicator (open clockwise). Furnish valves with valve position indicator. Valve shall be installed so that plug is sitting at top of the pipe above normal wastewater flow. Valve shall be as manufactured by Clow, DeZurik, or approved equal.

E. Gate Valves:

1. Gate Valves shall conform to the AWWA C509 Standard and shall be of the resilient-seated type with a 200 psi working pressure rating.
2. The gate valve shall be of iron body and cover construction with an elastomeric bonded cast iron disc and a non-rising bronze stem and bronze stem nut. The valve stem shall be sealed with a double "O" ring assembly. All valves shall be equipped with a handwheel which shall cause the valve to be opened by turning in a clockwise direction in a horizontal flow alignment.
3. All valves shall be mounted vertically in a horizontal flow alignment except for the valve on the emergency bypass connection
4. Valves shall be manufactured by Kennedy Valve Company, Mueller Company, or approved equal.

F. Flap Valve:

1. Iron Body, bronze mounted with flanged end. Provide stainless steel lifting cable to manually operate valve. Primary use is for valve vault drain line into wet well, installed in wet well.
2. Valve shall be manufactured by Clow Valve Co. (Fig. F-3012) or approved equal.

G. Emergency Bypass Line:

1. Provide an exterior 6" bypass line connection on the downstream side of the valve vault. Bypass line shall be used for flushing and draining of force main and bypass pumping.

2. See Standard Detail S-27 for more information.

H. Wet Well Isolation Valve:

1. A plug valve shall be installed on the gravity sewer entering the wet well, to allow the wet well to be isolated for future maintenance. The plug valve shall sit within a precast manhole (see Section 02605 for manhole requirements). See Paragraph 2.11.D above.

I. Surge/Pressure Relief Valve:

1. Install for pump station, if recommended by Pump Station Manufacturer, where water hammer is a concern, or where required by ENGINEER.
2. To be manufactured by GA Industries, Inc., APCO by DeZURIK Inc., or approved equal.
3. The sewage surge relief valve shall function to prevent high pressure surges in the pipeline. The valve shall be of a 90-degree elbow configuration. The valve disc shall be held in the closed position due to the action of externally mounted springs when the pipeline is under normal working pressure. If the pipeline pressure, acting on the valve disc, overcomes the spring force, the valve will open. The pipeline pressure at which the valve opens (i.e., relief setpoint) shall be adjustable by varying the spring tension. The valve shall remain open as long as the line pressure exceeds the relief setpoint. When pipeline pressure drops below the relief setpoint, the spring force shall close the valve. The rate of closure shall be adjustable by the action of an oil-hydraulic cylinder and flow control valve. The relief set point shall initially be 20 psi greater than the pump shut off head.
4. The main valve body, cover and disc shall be constructed of cast iron (ASTM A126-B). The valve body shall contain a bronze (optional - stainless steel) seat ring. The valve disc shall contain a resilient, replaceable seat ring of Thiokol treated leather or nylon held in place by a bronze (optional - stainless steel) follower ring. The disc shall be attached to a stainless steel stem guided by bronze bearings through a length not less than the valve diameter. A rod wiper shall be included for removal of solids adhering to the stem as the stem enters the bearings. The stem shall be attached to externally mounted spring(s). The spring load shall be generated by compressing the spring(s). Tensioned spring(s) are not acceptable. The springs shall be enclosed in steel enclosures and shall be provided with spring position indicators. Exposed springs are not acceptable. A hydraulic cylinder assembly shall be attached to the stem. The cylinder assembly shall be of bronze B-62. An oil reservoir and flow control valve shall be provided with the valve.

J. Pressure Gauge:

1. Provide bourdon tube pressure gauges, glycerin filled with 4½ inches dial size and range suitable for the line pressure. Accuracy shall be to 1% of full-scale. Furnish gauge with ½ inch NPT bottom connection and shut-off ball valve for liquid service. Furnish each gauge with Type 316 stainless steel diaphragm seals to protect from surges and solids. Provide pressure gauge in the valve chamber where indicated on the Drawings.

## 11306.2.11 CONTROL BUILDING

- A. A building shall be provided to house controls and the emergency standby generator. The building shall be brick exterior and CMU acoustic block interior (Soundblox or approved equal) with insulated acoustical louvers; reinforced concrete footing and floor slab; motorized operating dampers with insect screens; reinforced concrete interior generator pad; and gable truss roof. Color and material samples of all building components shall be provided for OWNER's review and selection. See Section 09900 for color requirements.
- B. Floor slab shall be reinforced and designed to span over the foundation walls. Generator pad shall be floating type. A structural and mechanical design prepared by, signed, and sealed by a Professional Engineer registered in the Commonwealth of Pennsylvania, shall be submitted to the AUTHORITY for review and approval.
- C. The building footprint shall be appropriately sized for the quantity and dimensions of the equipment to be placed inside of it, leaving adequate space to access the equipment and panels, future maintenance and upgrades, as well as meet all required electric code. A preliminary layout showing the floor plan and equipment shall be provided to the ENGINEER for approval. In addition, free/unused space inside the building shall be allotted for a potential future restroom (see Paragraph D below).
- D. Provide a restroom (with toilet and sink) in the Control Building where required by OWNER, with plumbing and trap tied directly to the wet well. Install in accordance with local plumbing code including a flapper type check valve at the wet well, a trap and vent at the building.
- E. Lighting: CONTRACTOR shall furnish and install a complete lighting system for the pump station building and site, consisting of indoor and outdoor general lighting, photo cells and switches, as indicated on the Drawings and as specified herein.
  - 1. All lighting fixtures, lamps, suspension systems and accessories furnished and installed under shall be energy-efficient and conform to the Specifications. Install all fixtures as indicated on the Drawings. The fixture locations indicated on the Drawings may be approximate and the CONTRACTOR shall verify all fixture locations with the Design Engineer before final installation. All fixtures shall have the UL label and be undamaged at the time of installation.
  - 2. Fluorescent lamps shall be cool white, LED type. Metal halide lamps for use in fixtures shall be diffuse coat type and matched to the lamp voltage of the fixtures. All lamps installed shall be manufactured by Sylvania, Phillips, or approved equal.
  - 3. Surface mounted fluorescent fixtures shall use at least two points of support, shall be secured to the structure and shall not depend on any part of the ceiling system or equipment as a means of support.
  - 4. Outside building lights shall be provided with a master photo cell control to automatically activate lighting at nighttime. A time clock shall not be substituted.
  - 5. All indoor lighting shall be controlled from a pair of three-way switches inside the Control Building. One three-way switch shall be provided inside each exterior door.

6. Emergency Exit/Light (at exterior doors): Sealed and gasketed, NEMA 4X construction. The unit shall be an emergency light with two (2) high intensity, 1.9 watt, 6 volt LED heads for emergency light, with battery backup capable of powering 3.7 watt of LED remote heads, lamps rated 120 volts AC, wall mounted with non-corrosive parts. NEMA 4X emergency light fixtures shall be as manufactured by Barron Lighting, Exitronix LED-RX Series, or approved equal.
- F. Heating and Ventilation: Control Building shall be electrically heated using unit heater(s) and ventilated with exhaust fan(s) and operating louvers/dampers, provided as part of the electrical work. All necessary hardware, controls, caulking, etc. which is required for complete systems shall be provided, including all control wiring.
1. Unit heaters shall be suspended mounting type, with fan forced air distribution over electric resistance heating coils. Fan to be sized appropriately for the size of the building. Thermostats for unit heaters shall be integral, low voltage, snap action type with anticipator. Heating shall be designed for a 60 degree Fahrenheit differential, plus infiltration. Depending on the size of the Control Building, AUTHORITY reserves the right to require multiple unit heaters, so that should one fail, some heating would still be provided. Unit heaters to be by Indeco or approved equal.
  2. Exhaust fans shall be propeller type, designed for adequate ventilation based on the room size and a 10 degree Fahrenheit temperature rise and/or 30 air changes per hour for intermittent ventilation. Fans shall have heavy duty guard, panels for full size of wall-mount opening, and motor side fan guard. Exhaust fans shall be Greenheck, Penn Ventilator Co., Inc., or approved equal. Provide all necessary accessories to ensure proper installation and operation, including wall housing, screens, seals, supports and exhaust hose. A wall-mounted thermostat shall be provided to control the exhaust fan.

#### **11306.2.12 STANDBY ELECTRICAL GENERATING SYSTEM**

- A. For emergency backup generator, automatic transfer switch, load bank and appurtenances, see Section 16622.

#### **11306.2.13 ELECTRICAL REQUIREMENTS**

- A. Purpose:

1. The following “Electrical Requirements” pertain to the electrical installations for typical sewage pumping stations having secondary utility services.
2. Requirements of the applicable paragraphs of the National Electrical Code (NEC) are to apply to these facilities. Those outlined below are to attain consistency in installations and equipment and to establish a basis for review in addition to NEC requirements.
3. These Specifications shall be considered to have equal weight as the requirements of Boroughs, Townships, State Agencies, etc., but are not intended to conflict with any of the above. Conflicts shall be noted and called to the attention of the AUTHORITY and ENGINEER.

- B. Design electrical supply and control circuits to meet the requirements of the National Electric Code, National Fire Protection Association and local jurisdictions as noted above, as well as the regulations of Bucks County, Commonwealth of Pennsylvania and OSHA.
- C. A transformer with fused overload protection shall be installed as necessary to provide a maximum of 120V to all control circuitry and accessory uses.
- D. Protect the motor control panel by conduit seals or other appropriate sealing methods meeting the requirements of the National Electric Code for Class I, Division 1, Group D locations.
- E. DEVELOPER/CONTRACTOR shall secure and pay for all inspections and permits required for this work by the Authorities having jurisdiction.
- F. Upon completion of the work, furnish to the AUTHORITY, two copies of an Electrical Certificate from an approved electrical inspection agency (agency to be approved by AUTHORITY ahead of the work).
- G. Electrical information to be included in the O&M Manuals shall include, but not be limited to, parts list, outline drawings, calibrations and settings, identification and terminal numbers, trouble shooting procedures, control diagrams, shop drawings, lubrication schedule (where applicable), and functional description of the equipment.
- H. Provisions shall be included for the AUTHORITY and ENGINEER to make tests for voltage level, insulation resistance, load balance and other electrical parameters affecting the proper operation of the systems. All labor and materials required for all such tests and the corrections necessary shall be as directed by the ENGINEER, at CONTRACTOR's expense.
- I. After all final adjustments have been made, the AUTHORITY's personnel shall be instructed in all details of operation and maintenance of electrical equipment installed on the project.
- J. Materials and Installations
  - 1. All materials shall be new, of the latest type and design. All materials of one type shall be of the same manufacture throughout the installation. Types of materials and styles shall be consistent throughout the installation. Where applicable, materials and equipment shall bear the label of the Underwriters' Laboratories, Inc.
  - 2. Each electrical equipment cabinet shall be equipped with a metal or plastic nameplate to indicate the equipment served. Equipment connected to a 480 volt system shall have nameplates and identifications with red backgrounds. Panelboards shall be equipped with a directory of circuits neatly typed on heavy white cardboard and placed within the directory holder in the panelboard door or on the panel front.
  - 3. Minimum conduit size shall be three-quarter inch (3/4") standard size.
    - a. Metal conduit shall be rigid threaded steel, zinc coated conforming to Federal Specification WW-C-581.

- b. Rigid non-metallic polyvinyl chloride (PVC) conduits to be used for underground applications only, and shall be Schedule 80 PVC for direct bury, and Schedule 40 PVC for concrete encased. To be manufactured by Carlon or approved equal.
  - c. All interior security and fire alarm conduit shall be EMT.
  - d. Flexible conduits shall be used for connections to motors, transformers, etc. Sealtite shall be used outdoors for flexible connections or where exposed to moisture. Aluminum conduit, EMT, IMT and cable assemblies are not acceptable.
4. Wire rated 600 volts shall be copper with type THHN/THWN insulation. Wires No. 8 AWG and smaller shall be solid single conductor and those larger than No. 8 shall be stranded. Except for control circuits, all wires shall be No. 12 AWG minimum. For controls and special circuits, use conductors not smaller than No. 14 AWG. Aluminum wires and busses are not acceptable.
5. Wall switches shall be quiet type with composition cups and handles and screw terminals. Switches shall be heavy duty rated 20 amperes, 120/277 volts, equal to Hubbell Model 1221, or approved equal. Convenience outlets shall be duplex grounding type, rated 20 amperes, 125 volts equal to Hubbell model GF-8300-GY (GFCI Type Hospital Grade), or approved equal. Plates for flush wiring devices shall be stainless steel with satin finish. Where devices are set in exposed fittings, galvanized or cadmium plated plates shall be used.
6. Safety switches shall be fusible or non-fusible, horsepower rated, quick-make and quick-break meeting NEMA standards for Heavy Duty Type HD switches in NEMA 12 enclosures. All fuses shall be dual-element type. Furnish one (1) spare fuse for every one (1) installed.
7. Fixtures, materials and equipment shall be protected at all times. Conduit openings shall be closed with caps or plugs during installation. Fixtures and equipment shall be tightly covered and protected against dirt and injury. At the completion of all work, the fixtures, materials and equipment shall be thoroughly cleaned and left in a condition satisfactory to the ENGINEER.
8. No electrical fixtures shall be located inside the valve vault or wet well. Two (2) spare conduits shall be provided to the valve vault. Any time running conduit into the valve vault or wet well, the conduit shall first be brought up above grade into a junction box to provide an air gap and eliminate groundwater from entering the vault or wet well via the conduit.
9. Wet well junction box shall be a post mounted NEMA 4X fiberglass enclosure installed adjacent to the wet well at a height of 36" to top of enclosure. Key type lockouts shall be provided to shut down power to each pump (disconnect switches). Wiring shall be thermoplastic insulated copper conductors installed in rigid threaded galvanized conduits with appropriate seals as required for explosion-proof construction (Class I, Division 1, Group D). Location of these junction boxes shall be protected from vehicular traffic and shall not impede access to the wet well and the removal of pumps by a crane truck.

## K. Methods of Wiring

1. All wiring shall be thermoplastic insulated copper conductors installed in rigid threaded steel or aluminum conduit (interior or above grade) or rigid plastic PVC heavy wall conduit (below grade). When running underground conduit outside the building or vaults, all conduits shall be encased in a three inch (3") concrete envelope around circumference of the conduit.
2. All conduits (metal or plastic) shall contain an equipment ground wire having green color insulation. All other grounding shall be as provided for in Article 250 of the latest National Electric Code. Connections to driven ground rod electrodes shall be made by the Cadweld exothermic welding process.
3. Splices for four (4) No. 10 AWG wires (or less) shall be T&B Series PT or RP, Scotchlok Spring type or Ideal Wing Nut. Connectors of No. 10 AWG wires and smaller to switches, receptacles and panelboards shall be of the clamp or screw type. Terminations and splices for conductors larger than No. 10 AWG shall be of the compression type made with a compression tool and die recommended by the manufacturer or pressure utilizing pressure of a bolt and nut. Lugs and connectors shall be T&B or Burndy. Wire nuts shall not be permitted. All single conductor power cable shall be furnished and installed in continuous lengths without splices or taps. Conductors shall be continuous from enclosure to enclosure and no splices shall be made in the raceway system except within the junction boxes.
4. Anchors and Fasteners: Unless otherwise required by ENGINEER, all raceway systems shall be supported from/to walls, ceilings, floors or process equipment using a u-strut channel system as manufactured by Unistrut Corporation, B-Line Systems, Robroy or approved equal. The use of one and two-hole conduit straps, clamp backs, Madison hangers, or conduit clips will not be permitted. All aluminum, fiberglass and stainless steel u-strut support system parts furnished and installed shall be of the same manufacturer. Mount all u-strut channel supports as follows:
  - a. Masonry (Hollow Block) - Furnish and install, four-way expansion anchors type 1104, 1105, and 1106 as manufactured by U.S.E. diamond or lead caulking anchors (with set tool) or approved equal. Minimum size bolt shall be 1/4 in. thread x 1 inch long stainless steel.
  - b. Masonry (Solid Block) - Furnish and install stainless steel, hex head sleeve anchors cores as manufactured by Hilti Inc., or approved equal. Minimum size shall be 1/4 inch thread X 1 inch long.
  - c. Masonry (Solid Concrete) - Furnish and install stainless steel stud type, drive in, anchor bolts with stainless steel nuts and washers as manufactured by Hilti Inc., "KWIK BOLT", or approved equal. Minimum size shall be 1/4-20 X 3 inches.
  - d. Steel Beams - Furnish and install stainless steel u-strut angular beam clamps with stainless steel bolts, B-Line catalog no. B314SS4 (two for each u-strut location).

- e. Wood Framing (Ceiling and Roof Rafters) for U-Strut Supports - Furnish and install stainless steel, hex head lag screws with stainless steel washers as supplied by McMaster-Carr or approved equal. Minimum size shall be 1/4 inch thread x 2-1/2 inches long.
- f. All u-strut conduit clamps installed outdoors and in valve vaults/manholes shall be stainless steel. All u-strut conduit clamps installed indoors shall be aluminum with stainless steel bolts/nuts/washers.
- g. In all outdoor and underground locations including hand holes and vaults, stainless steel u-strut shall be used. All u-strut channel fittings, pipe clamps, nuts, washers, bolts and moldings furnished and installed in these areas shall be manufactured of #302 stainless steel. U-strut channel shall be Unistrut Corporation type #P1100SS, measuring 1-5/8 inches X 1-5/8 inches X .075 inches (thick), or approved equal. All u-strut nuts, washers, bolts, moldings, fittings and pipe clamps furnished for installation shall be stainless steel.
- h. In all indoor areas, u-strut channel shall be manufactured of #5052-H32 aluminum. U-strut channel shall be Unistrut Corporation type #P1000RA, measuring 1-5/8 inches X 1-5/8 inches X .05 inches (thickness) or approved equal. All aluminum u-strut channel shall be square cut with all cut end edges filed before installation. All u-strut nuts, bolts moldings, and fittings, furnished for installation with aluminum u-strut shall be compatible with the #P1000RA series, shall be stainless steel and installed according to the manufacturer's recommendations. All u-strut conduit clamps for use with aluminum u-strut shall be manufactured of 5052 aluminum.

L. Service and Distribution

- 1. Electric services will typically be from PECO or PP&L systems using secondary rates. Installations exceeding 125 KW on lines should be studied for rate HT, with the conclusions submitted to the AUTHORITY for review. Service voltage characteristics shall be customized for each location after considering the distance of pump motor(s) from the utility transformer and the available voltage ratings of the pump motors. The system shall be designed to minimize voltage losses, transformer losses and operating costs. Most installations will be best suited to a 240/120 volt, 3 phase, 4 wire or 208Y/120 volt, 3 phase, 4 wire system. Where motor horsepower or voltage considerations warrant, a 480Y/277 volt, 3 phase, 4 wire system shall be considered.
- 2. In general, electric, cable and telephone services shall be underground. Utility charges and all installation costs for underground services shall be included in CONTRACTOR's costs. A minimum of one spare conduit shall be provided for underground electric and one spare conduit for telephone.

3. Evidence of coordination with the Utility shall be provided to the AUTHORITY in the form of correspondence, including a letter on the Utility's letterhead identifying the project, location, etc., as well as the approximate loads and the ability to handle starting currents, etc. Copies of service and meter applications shall also be included.
4. Systems shall be designed with a single main disconnect. The six (6) main disconnect provision of the NEC is not acceptable. Fusible switches shall not be used for main disconnects or distribution circuits. Distribution and lighting panels with copper busses shall be used in lieu of individual circuit breakers with wiring gutters. Spares and spaces shall be included, consistent with good practice.
5. Circuit breakers shall be quick-make and quick-break bolt-on type, trip-free, with inverse time characteristics, etc. Automatic tripping shall be clearly indicated by the operating handle, assuming a neutral position midway between the manual ON and OFF positions. Circuit breakers shall be designed so that an overload in one pole will automatically cause all poles to open through a trip bar. Plug-in equipment is not acceptable.
6. Lighting transformers, where required, shall be of the air cooled dry type. All transformers shall incorporate a UL Class 220 degrees C insulation system (Class H) in accordance with National Electrical Manufacturers Association Standard ST-20 and its latest revisions. Primary windings shall have six (6) full capacity 2-1/2% taps, 4 below and 2 above rated high voltage.
7. Power and control wiring shall be complete for all motors and power consuming devices, including correct sizes and adjustments of overload, correct rotation of motors, all control wiring, interlock wiring and all other wiring for the complete satisfactory operation of the installation.

M. Power System Studies:

1. After approval of Shop Drawings for distribution equipment, CONTRACTOR shall perform a short circuit analysis, coordination study and flash hazard study of the electrical system.
2. CONTRACTOR shall obtain all necessary information from the utility power company for the studies.
3. CONTRACTOR shall obtain from the equipment suppliers, all necessary information for the studies, including estimates of cable lengths.
4. CONTRACTOR shall submit a preliminary power system study before any equipment is purchased.
5. CONTRACTOR shall update and resubmit the preliminary power system study after all equipment has been installed and startup is complete. This shall be the final power system study, and shall include ENGINEER's comments from reviews of the preliminary study as well as updates for actual cable lengths installed.

6. A Professional Engineer registered in the State of PA shall seal all of these studies. The studies shall be performed in accordance with the recommended procedures as outlined in ANSI/IEEE 399 and ANSI/IEEE 242. See ENGINEER for more specific requirements of these studies.
7. Short Circuit Study: Determine the short circuit current available at each component of the electrical system and the ability of the electrical component to withstand and interrupt the current. Account for all possible operating scenarios. Results shall be summarized in a final report, and shall include conclusions and recommendations.
8. Coordination Study: Determine protective device characteristics, settings or sizes that provide a balance between equipment protection and selective device operation that is optimum for the electrical system. A final report shall be provided summarizing the results, with conclusions and recommendations. Equipment shall not be purchased until the preliminary version of this report is reviewed and approved by ENGINEER. CONTRACTOR to be responsible for adjusting the settings of all circuit breakers in the study.
9. Flash Hazard Analysis Study: CONTRACTOR shall perform a flash hazard study of all buses and equipment shown on the single line diagram and any buses used in the short circuit study.
  - a. The results of each scenario's flash hazard study shall be tabulated in an Excel spreadsheet listing the required information for each bus shown on the study's single line diagram and all buses shown on the short circuit study. Perform in accordance with NFPA 70E using IEEE 15884/NFPA 70E 2012 Annex D.7 calculation method.
  - b. CONTRACTOR shall create flash hazard warning/safety labels for all equipment shown on the single line diagram, all equipment buses listed in the short circuit study including all disconnect switches, the 240/120 volt lighting panel and associated transformer, and all other circuit breakers installed in equipment/control panels/motor starters. Each label shall be minimum 3 inch wide by 4 inch high and shall include all required information per NFPA 70E.

#### **11306.2.14 PAINTING**

- A. Paint colors shall be selected based on the guidelines detailed in Section 09900. The color schedule is for guidance only. A color chart must be submitted to the AUTHORITY to confirm colors to be selected for specific pump station project sites.

### **11306.2.15 STAINLESS STEEL PORTABLE HOIST ASSEMBLY**

#### **A. Portable Hoist:**

1. A portable hoist which can be seated in floor style sockets bolted into the top slab of wet well shall be provided. The hoist shall be constructed of stainless steel, with stainless steel cable.
2. The hoist shall have a capacity substantially in excess of the weight of a pump and grinder and shall be capable of lifting the pumps or grinder without entering the wet well.
3. The portable hoist shall be manufactured by Thern Inc. (1-800-843-7648), Halliday Products, or approved equal.
4. Mounting Sockets: Floor style stainless steel sockets for the portable hoist shall be provided where necessary in order to properly lift the pumps as well as the sewage grinder/trash basket.

### **11306.2.16 SITE LIGHTING**

#### **A. Above Wet Well:**

1. Aluminum pole suitable for mounting on concrete base. Locate where protected from vehicular traffic, and not to hinder maintenance on the wet well or other facilities.
2. Height - 12 feet (maximum)
3. Floodlight shall be a heavy duty aluminum fixture, impact resistant glass and a 500 watt quartz lamp. This light shall not operate on photo cell; instead, it shall be controlled by a labeled switch located inside the front door of the Control Building.

- B.** Provide lights on walls of Control Building, where indicated by OWNER and ENGINEER. Provide screens where directed, so the light is directed downward, to avoid complaints from neighbors.

### **11306.2.17 WIRELESS IP CAMERA SYSTEM**

- A.** Coordinate through “The Wire Guys TWG, Inc.”, and as approved by the AUTHORITY.
- B.** Provide and install camera(s) mounted on pole(s) to obtain adequate coverage of the Site.
- C.** Include local/remote DVR, power, and all necessary appurtenances to ensure a fully functioning system.
- D.** Costs to be paid by the DEVELOPER.

## **PART 3 - EXECUTION**

### **11306.3.01 GENERAL**

- A. Refer to the Drawings for location and pertinent elevations of the wet well, valve chamber and related equipment associated with the proposed sewage pumping station.
- B. All electrical work shall conform with the National Electrical Code, latest edition, along with the requirements and conditions of PECO Energy, PP&L or the local electric provider.

### **11306.3.02 CLEARING AND GRUBBING**

- A. Clear and grub the pump station site as required to construct facilities in accordance with Drawings and as specified in Section 02110.
- B. A site inspection will be made with the ENGINEER to determine which of the existing trees are to remain and which shall be suitably protected.

### **11306.3.03 EXCAVATION**

- A. Excavate at the location of the wet well and valve chamber to the depth and area required as shown on the Drawings and as specified in Section 02220. Install a minimum of 8" compacted PADOT 2A modified aggregate subbase.
- B. Construct pump station basin of precast concrete sections of the size and configuration as shown on the Drawings.

### **11306.3.04 CONSTRUCTION**

- A. Wet Well:
  - 1. Construct wet well of precast sections, as shown on the Drawings.
  - 2. Seal joints between precast concrete sections with two (2) rings of preformed joint sealant compound.
    - a. Place joint sealant compound on lower section to be squeezed by the weight of the upper section.
- B. Valve Chamber:
  - 1. Construct valve chamber of precast sections, as shown on the Drawings.
  - 2. Seal joints between precast concrete sections with two (2) rings of preformed joint sealant compound.
    - a. Place joint sealant compound on lower section to be squeezed by the weight of the upper section.

C. Piping and Miscellaneous Structural Work:

1. Connect the incoming sewer line to the wet well by means of the integrally cast resilient connection in accordance with the Drawings.
2. Install the ductile iron pump discharge and return lines between the wet well and valve chamber in accordance with the Drawings. All buried pipe connections shall be mechanical joint. Piping within wet well and valve chamber shall be provided with a restraint system to prevent movement caused by normal working pressure and surge pressure at pump start/stop. Each pipe line leaving the wet well and valve chamber shall be provided with a sealing device in order to provide a watertight condition.
3. Install the force main exiting the valve chamber in accordance with Section 02610 and the Drawings.
4. Connect the drain line between the valve chamber and wet well by means of an integrally cast resilient connection in accordance with the Drawings.
5. Create the bottom of the wet well in accordance with the Drawings using mass concrete.
6. Complete vent pipe assembly on top slab of wet well and valve chamber as required in accordance with the Drawings.
7. Securely fasten the ladder in the valve chamber at the location shown on the Drawings.

D. Leakage Test:

1. An exfiltration test shall be performed on the wet well and valve chamber once the piping connections have been completed. The test shall be performed as follows:
  - a. All pipe openings shall be plugged with water tight plugs.
  - b. The structure shall be completely filled with water one hour prior to the start of the test to saturate the concrete.
  - c. The structure shall be refilled to the top, and in the presence of the ENGINEER the test started. The water level shall be maintained at the top, for a period of four (4) hours, with an accurate record kept of the quantity of water added during the period.
  - d. The structure shall be acceptable if the rate of exfiltration does not exceed 0.1 gallons per foot of diameter per vertical foot per hour (for circular structure). For underground chambers with non-circular cross-sections, the diameter used to calculate the maximum allowable rate of exfiltration shall be the equivalent diameter of a circle with the same cross-sectional area as the chamber.
  - e. If the structure fails the test, repairs shall be made, and structure retested until satisfactory results are obtained.

E. Equipment:

1. Install pumps, VFDs, motors, controls and other accessory equipment in strict accordance with the manufacturer's written instructions.
2. The installation of each equipment item shall be inspected, adjusted, approved and certified satisfactory by the manufacturer. Obtain and submit an installation certificate signed by the equipment manufacturer's representative attesting that the equipment has been properly installed and is ready for start-up and performance testing.

F. The pump discharge base plate and piping between the wet well and valve chamber shall not be set in the final position until the top slab with access hatches is set. The pump base and piping shall be adjusted to obtain the maximum clearance between the hatches and pumps.

G. A stainless steel bracket shall be mounted inside the wet well, adjacent to the hatch opening and accessible from the top by the CONTRACTOR to hold and position the level probe, in conjunction with backup floats and electrical cables.

H. Performance Testing:

1. Upon completion of all work including adjustment of the equipment in a manner satisfactory to ENGINEER, the equipment shall be tested by placing it in full operation for a period of at least seven (7) days. Prior to putting the equipment in operation, CONTRACTOR shall give ENGINEER at least seven (7) days written notice. On the day designated by CONTRACTOR for test start and approved by ENGINEER, CONTRACTOR's personnel with AUTHORITY's personnel observing, shall demonstrate to ENGINEER the mechanical performance of the equipment covered by these Specifications. If the demonstrations are satisfactory to ENGINEER, the test will be considered concluded after seven (7) days of continuous service without any mechanical or electrical failures. If deficiencies are found, they shall be corrected by CONTRACTOR and the test restarted until the ENGINEER determines that the equipment has performed satisfactorily.
  - a. Part of the testing shall include the CONTRACTOR pulling each submersible pump from the wet well, and subsequently resetting it in the presence of the ENGINEER, to verify the integrity of the slide rail system and quick disconnect discharge flange.
2. During tests, all normal operation costs shall be paid for by CONTRACTOR. Operating costs shall be understood to include only the cost of electric power, water, grease, lubricating oils, and the wages of CONTRACTOR's personnel.
3. During the test, CONTRACTOR shall be responsible for demonstrating that each piece of equipment, including controls, can operate as specified and to the satisfaction of AUTHORITY.

4. At any time within a twenty four (24) month period, subsequent to completion of herein specified tests, CONTRACTOR at the request of the AUTHORITY or ENGINEER, shall furnish AUTHORITY with services of Pumping Station equipment manufacturer's representatives for a period of two (2) man-days, at no cost to AUTHORITY. Furthermore, said services shall be additional to those furnished in connection with equipment erection, installation, testing and the correction of deficiencies.
  - a. Services provided shall consist of furnishing detailed instructions to AUTHORITY personnel regarding equipment and maintenance after personnel of AUTHORITY have had an opportunity to become familiar with Pumping Station equipment.

I. Water Supply System:

1. Construct a water service to the pump station site. The system shall include all materials and labor required to provide a water service including excavation, backfill, corp stop, pipe, curb stop and box, meter pit basin, backflow preventer, freezeless yard hydrant, and restoration.
2. Freezeless yard hydrant shall be installed within 20 feet of the wet well for maintenance, at a location protected from vehicular traffic. Yard hydrant to be Woodford Model Y1 or approved equal.
3. The DEVELOPER shall be responsible for obtaining all approvals and permits for the water supply system. A service connection to a public water supply system shall be provided, if reasonably available. The service connection and plumbing shall conform to relevant local plumbing codes, the requirements of the Pennsylvania Department of Environmental Protection and the Department of Health.
4. When connection to a public water supply system cannot be provided, a groundwater production well shall be constructed on the pump station site as the source of supply. The well shall be constructed in accordance with AWWA A100, and any relevant local codes. The well shall be developed and tested to produce a minimum safe yield of 5 gallons per minute. The well shall be equipped with a submersible well pump and pitless adapter. A pre-pressurized diaphragm-type hydropneumatic tank, with pressure switch, pump controls and all appurtenances shall be installed to automatically operate the well pump. The hydropneumatic tank shall be located in the control building or a heated, above-ground, weather-proof enclosure. All on-site production wells are to be operated as private non-potable water supplies, and the DEVELOPER shall provide the following warning sign in 2-inch block letters at the yard hydrant and all fixtures: "WARNING; NON-POTABLE WATER SUPPLY – DO NOT DRINK".

**11306.3.05 BACKFILLING AND COMPACTING**

- A. Backfill around structures with PADOT 2A coarse aggregate, only after approval received from the ENGINEER.

- B. Place backfill in approximately equal lifts on opposite sides of the structure to equalize opposing horizontal pressures.
- C. Backfill and compact in accordance with the Drawings and as specified in Section 02220.

**11306.3.06 SITE WORK**

- A. Once the pump station structures have been completed, the following site work shall be completed in accordance with the Drawings and as specified in the noted Sections.
  - 1. Construct 12-foot wide access road with turnaround in accordance with Section 02575.
  - 2. Construct a chain link fence with vehicular gate and personnel gate surrounding the pump station area in accordance with Section 02832. All non-paved areas within the fencing shall be covered with 3" of 2A coarse aggregate. Provide a continuous layer of PennDOT Type B Class 2 Geotextile Fabric under the stone, above the prepared subgrade, as a weed barrier.
    - a. Fencing to be PVC Coated Steel Fencing (Color = Black). See Section 02832 for additional requirements.
  - 3. Finish grade, topsoil, and seed all disturbed areas surrounding the fence. Plant trees and shrubs of the size and type as shown on the Drawings and in accordance with Section 02905.

**END OF SECTION**

**SECTION 15260  
PIPING INSULATION AND HEAT TRACING**

**PART 1 - GENERAL**

**15260.1.01 SUMMARY**

A. Section Includes:

1. Piping Insulation
2. Jackets and Accessories
3. Heat Tracing

**15260.1.02 QUALITY ASSURANCE**

A. Materials: Flame spread/smoke developed rating of 25/50 or less in accordance with ASTM E84, NFPA 255, and UL 723.

B. Qualifications:

1. Applicator: Company specializing in performing the work of this section with minimum three (3) years experience.

**15260.1.03 SUBMITTALS**

A. Submit product data on insulation and heat tracing in accordance with Section 01010. Provide list of materials and thickness for each service, locations, and heat tracing systems. Include manufacturer's recommended installation instructions and field test procedure.

B. Submit design data for sizing heat trace.

**15260.1.04 DELIVERY, STORAGE, AND HANDLING**

A. Deliver materials to site in original factory packaging, labeled with manufacturer's identification, including product density and thickness.

B. Properly store, adequately protect, and carefully handle materials to prevent damage before and during installation. Handle, store, and protect materials in accordance with the manufacturer's recommendations. Replace damaged or defective items.

1. Store insulation in original wrapping and protect from weather and construction traffic.
2. Protect insulation against dirt, water, chemical, and mechanical damage.

## **15260.1.05 PROJECT/SITE CONDITIONS**

### **A. Environmental Requirements:**

1. Maintain ambient temperatures and conditions required by manufacturers of adhesives, mastics, and insulation cements.
2. Maintain temperature during and after installation for minimum period of 24 hours.

## **PART 2 - PRODUCTS**

### **15260.2.01 GLASS FIBER INSULATION**

A. Acceptable Manufacturers: CertainTeed, Knauf, Owens-Corning, or approved equal.

B. Insulation: ASTM C547; rigid molded, noncombustible.

1. "K" Value: 0.26 at 75°F
2. Minimum Service Temperature: -20°F (-28.9°C)
3. Maximum Service Temperature: 850°F (454°C)
4. Maximum Moisture Absorption: 0.2 percent by volume

C. Vapor Barrier Jacket:

1. ASTM C921, White kraft paper reinforced with glass fiber yarn and bonded to aluminized film.
2. Moisture Vapor Transmission: ASTM E96; 0.02 perm inches.
3. Secure with self-sealing longitudinal laps and butt strips.
4. Secure with outward clinch expanding staples and vapor barrier mastic.

D. Tie Wire: 18 gauge stainless steel with twisted ends on maximum 12-inch centers.

E. Vapor Barrier Lap Adhesive: Compatible with insulation.

F. Insulating Cement/Mastic: ASTM C195, hydraulic setting on mineral wool.

G. Minimum insulation thickness shall be as follows:

1. 2" pipe and smaller = 1 inch
2. Pipe greater than 2" = 2 inch.

### **15260.2.02 CELLULAR GLASS**

- A. Material: Inorganic, foamed or cellulated glass, annealed, rigid, hermetically sealed cells, incombustible.
  - 1. ASTM C552, Type II, Class 2 (jacketed)
  - 2. Density: 7.5 pcf (average)
  - 3. "K" Value: 0.29 at 75°F

### **15260.2.03 JACKETS**

- A. Piping Insulation
  - 1. Indoors: PVC plastic ASTM C92, one piece molded type fitting covers and sheet material, off white color.
    - a. Thickness: 15 mil
    - b. Connections: Brush on welding adhesive
  - 2. Outdoors: Weatherproof aluminum alloy jacket, 0.010" thick, with 3/16" corrugations and integrally bonded moisture barrier over the entire surface in contact with the insulation. Provide aluminum straps, seals, and hardware. Outdoor jackets shall be as manufactured by Childers Products Co., Inc., or approved equal.

### **15260.2.04 HEAT TRACING**

- A. Electric heat tracing for the purpose of freeze protection shall be installed on the piping with insulation and jacketing as indicated on the Drawings, and as specified herein.
- B. The heat tracing shall be capable of maintaining a minimum water temperature of 40°F at an ambient temperature of -10°F. The electric heat tracing shall be a self-regulating heater. The heater shall respond to varying localized temperature conditions along the pipe by self-regulating its heat output at each point along its length without reliance on thermostat controls.
- C. Operating energy shall be conserved by the self-regulating feature of the heater material, which automatically controls heat output in proportion to the heat requirement. Operating safety shall be increased by the absolute heater temperature limit built into the self-regulating heater material without a reliance on thermostats. A constant wattage heater shall not be acceptable.
- D. The electrical heat tracing shall consist of flat, flexible, low-heat density electric heat tracing strip of parallel circuit construction, consisting of 16 AWG bus bars and a continuous inner core of self-regulating conductive material. This core shall be insulated with a radiation cross-linked polyolefin jacket. The heat-tracing strip shall be capable of being cut to the desired length in the field. Manufacturer's components shall be used for all power connection points, heat tracing tees, and end seal terminations.

- E. The self-regulating heater, in combination with the interconnect components and power connection kit junction box, NEMA 4X, shall have a UL system listing. Provide a complete kit for heat trace application, including cable and power connection box with ambient sensing thermostat.
- F. Electric heat tracing shall be Chromalox, Thermon, or approved equal.
- G. Electric heat tracing thermostats shall be ambient sensing, Chromalox DL Series, Model RTAS, or approved equal.

## **PART 3 - EXECUTION**

### **15260.3.01 EXAMINATION**

- A. Verify that piping has been tested before applying insulation materials.
- B. Verify that surfaces are clean, foreign material removed, and dry.

### **15260.3.02 INSTALLATION**

- A. Install materials in accordance with manufacturer's instructions.
- B. On exposed piping, locate insulation and cover seams in least visible locations.
- C. Insulated cold pipes conveying fluids below ambient temperature:
  - 1. Provide vapor barrier jackets - factory applied or field applied.
  - 2. Insulate fittings, joints, and valves, with molded insulation of like material and thickness as adjacent pipe.
  - 3. Provide PVC fitting covers.
  - 4. Continue insulation through walls, sleeves, pipe hangers, and other pipe penetrations.
  - 5. Insulate entire system including fittings, valves, unions, flanges, strainers, flexible connections, pump bodies, and expansion joints.
- D. For insulated pipes conveying fluids above ambient temperature:
  - 1. Provide standard jackets with vapor barrier - factory applied or field applied.
  - 2. Insulate fittings, joints, and valves with insulation of like material and thickness as adjoining pipe.

- 3. Finish with glass cloth and adhesive.
- 4. Insulate flanges and unions.
- E. Finish insulation at supports, protrusions, and interruptions.
- F. Secure cellular glass insulation with manufacturer's recommended adhesive. Seal joints with manufacturer's recommended joint sealer. Use pit wrap jacketing with buried cellular glass insulation.
- G. For exterior applications, provide vapor barrier jacket. Insulate fittings, joints, and valves with insulation of like material and thickness as adjoining pipe, and finish with glass mesh reinforced vapor barrier cement. Cover with aluminum jacket with seams located on bottom side of horizontal piping.
- H. For heat-traced piping, insulate fittings, joints, and valves with insulation of like material, thickness, and finish as adjoining pipe. Size large enough to enclose pipe and heat tracer. Cover with PVC or aluminum jacket, as required, with seams located on bottom side of horizontal piping.

**15260.3.03 TOLERANCE**

Substituted insulation materials shall provide thermal resistance within 10 percent at normal conditions, as materials indicated.

**15260.3.04 PIPE INSULATION SCHEDULE**

<u>Piping System</u>	<u>Insulation Type</u>	<u>Pipe Size</u>	<u>Minimum Thickness (inch)</u>
Process Piping (Exterior and Above-grade)	Glass Fiber	4"-12"	2"
Process Piping (Below grade where indicated on Drawings)	Cellular Glass	4"-6"	1-1/2"

**END OF SECTION**

**SECTION 16622**  
**STANDBY ELECTRIC GENERATING SYSTEM**

**PART 1 - GENERAL**

**16622.1.01 DESCRIPTION**

- A. Furnish, install and acceptance test a complete and operable standby electric generating system, including all devices and equipment specified in this Section or required for the service. Equipment shall be brand new, factory tested and delivered ready for installation. The generator system shall include an automatic transfer switch and load bank.
- B. Manufacturer/supplier shall provide startup services, on-site acceptance testing, and training following the installation.
- C. Emergency power systems shall include diesel driven engine-generator, fuel system, cooling system, automatic starting system, controls, wiring and all necessary accessories. No rotating parts or hazardous components shall be exposed and all normal adjustments and maintenance shall be accomplished without the use of special tools.
- D. The rating of the engine generator shall be substantiated by the vendor's calculations (provided for ENGINEER's approval) and shall be based on a continuous rating. The engine generator shall be capable of satisfactory operation with all present and future motors and respective starting equipment in the sequence required for proper operation of the facility. Load shedding to reduce generator capacity shall not be considered without approval of the AUTHORITY.
- E. Exhaust silencers shall be critical type. A flexible fitting shall be provided for the sections of the exhaust piping between the exhaust manifold and the exhaust pipes. Drip fitting shall be included at the proper location for draining the exhaust system. Exhaust piping shall be adequately supported at least 12 inches from any combustible materials. Exhaust piping shall be insulated and jacketed for its entire length. Supports shall permit movement due to expansion and contraction. A ventilation thimble, or air sleeve, shall be provided where the exhaust pipes penetrate any building wall, ceiling or roof and proper caulking and waterproofing shall be included. Exterior end of the exhaust pipe shall be cut at a 45 degree angle to its axis, provided with a screen to prevent entrance of birds or animals and be directed away from residential areas.
- F. Storage battery shall be of the heavy-duty diesel starting type. The battery system shall be of sufficient size to provide for five (5) consecutive full starts without recharging, but in no case less than 200 ampere hours.

- G. Automatic transfer switch shall meet the requirements of UL 1008 and shall be furnished and warranted by the manufacturer of the engine generator to ensure one source of responsibility and compatibility for the entire Emergency System. Transfer switch shall be quick-make, quick-break double throw type, positively interlocked mechanically and electrically to prevent simultaneous closing, either by accident or intent. It shall have an isolation “bypass feature” to switch manually to the generator in the event of a power outage plus a failure of the transfer switch itself. See Paragraph 2.02 of this Section for additional requirements.
- H. A remote Emergency Stop button shall be provided which shall have red mushroom head and legend plate lettered “EMERGENCY STOP”. Remote “emergency stop” buttons shall be provided in the control building to shut-off the generator. One switch shall be located within 4-inches of the door jamb of each exterior door.
- I. Prior to acceptance of the installation, the engine-generator shall be subjected to testing in the presence of the AUTHORITY and ENGINEER. Defects, which become evident during this test, shall be corrected by CONTRACTOR and additional full load test(s) performed to the approval of the AUTHORITY and ENGINEER. After the acceptance and load tests have been completed, provide four (4) hours of an authorized factory representative at the site to instruct the OWNER’s operating personnel of the proper operation and maintenance procedures for this equipment.
- J. A remote fuel fill system shall be provided, allowing the generator fuel tank to be filled from the exterior of the Control Building. At a minimum, this shall consist of a 5 gallon spill containment box and remote alarm fill panel with audible alarms and tank gauge indicator.
- K. Fuel and exhaust piping in the building shall be black iron with threaded fittings. Install flexible connections at the engine. Piping to be sized to minimize refueling time.
- L. Ventilating air for the generator shall be provided by a combination of motorized intake dampers, an additional smaller gravity damper, and exhaust fans. Motor operated dampers shall be arranged and connected so that the damper(s) will be open when the respective exhaust fans or generator are running and closed when they are shut down. Dampers, which are integral with exhaust fans, shall be arranged so that normal air flow will not be impeded by operation. Calculations shall be provided that ensure adequate total “free area” of the intake louvers/dampers is provided for the required air flow with generator running, to prevent rain from penetrating said louvers/dampers.

#### **16622.1.02 QUALITY ASSURANCE**

- A. The manufacturer shall have experience in the design, manufacturing, supplying and commissioning of the type of equipment specified for this project, with a minimum of ten years documented experience and service facilities within fifty (50) miles of the project site. The equipment quoted shall be of a proven design and shall be referenced by at least ten (10) installations of similar size, having been in successful operation for a period of not less than five (5) years.

- B. All equipment shall be furnished by one supplier in whom system responsibility shall rest. The supplier shall be the manufacturer's authorized distributor, who shall provide the initial start-up services, conduct acceptance testing in the field, and warranty service. The supplier shall have a 24-hour service with factory trained service technicians.

### **16622.1.03 SUBMITTALS**

Submit the following information in accordance with Section 01010 to establish compliance with the specifications.

- A. Submittal drawings showing plan and elevation views indicating overall dimensions, and wiring interconnection details. Wiring diagrams to show all external connections required, with field wiring terminations labeled in a consistent point-to-point method. Provide drawings on fuel tank and generator showing dimensions, mounting details, radiator/fan mounting, fuel pipe connections, generator circuit breaker, and miscellaneous items.
- B. Manufacturer's product literature and performance data, sufficient to verify compliance with specification requirements. Include information on all components of the system.
- C. Manufacturer's test reports, indicating the results of performance testing. Submit a report listing motor starting for typical size machine. List voltage drop, power factor and loads started.
- D. Manufacturer's Compliance Statement, certifying that the equipment meets or exceeds the specified requirements. Describe any differences between the specified equipment and the proposed equipment specifically.
- E. Manufacturer's installation instructions. Include instructions for storage, handling, protection, examination, preparation, installation, and starting of the equipment.
- F. Manufacturer's warranty information.

### **16622.1.04 WARRANTIES**

For a period of 24 months from start-up, the equipment manufacturer shall warrant that the equipment covered by these Specifications shall be free from defects in material and workmanship under normal use and service. The manufacturer shall agree to repair or replace F.O.B. point of shipment such equipment, or any part thereof, previously furnished by them which is found to be defective during the warranty period. The warranty shall cover all parts, labor, and miscellaneous costs associated with repair of defective parts of the generator system. The warranty shall cover 24 hour a day, emergency response of service personnel to the site within two hours of receipt of request for service from the OWNER.

### **16622.1.05 OPERATION AND MAINTENANCE MANUALS**

- A. Submit in accordance with Section 01010 (4 final copies required).

- B. Include instructions for typical operations. Include instructions for routine maintenance requirements, service manuals for engine and fuel tank, oil sampling and analysis for engine wear, and emergency maintenance procedures.
- C. The O&M Manuals shall include a complete itemized list of engine parts and itemized parts list of the generator, control panel and other miscellaneous equipment supplied with the generator package. It shall also include the name, address and emergency telephone number of the closest authorized service agency. The manuals shall include all approved Shop and Record Drawings and product literature, as well as all as-built drawings.

#### **16622.1.06 REGULATORY REQUIREMENTS**

- A. Conform to requirements of NFPA 70, NFPA 110, and NFPA 101. Furnish products listed and classified by Underwriters Laboratories as suitable for the purpose specified and indicated.

### **PART 2 - PRODUCTS**

#### **16622.2.01 DIESEL ENGINE GENERATOR SET**

- A. Acceptable Manufacturers:
  - 1. MTU Detroit Diesel/Onsite Energy
  - 2. Kohler Power Systems
  - 3. Substitutions in accordance with Section 01010, Paragraph 1.05.
- B. Performance: The generator set manufacturer shall verify the diesel engine as capable of driving the generator with all accessories in place and operating at the generator set kW rating after derating for the range of temperatures expected in service and the altitude of the installation.
  - 1. The manufacturer shall provide documentation demonstrating satisfactory prototype test results for the model specified and production tests results for equipment supplied for this project. Generator sets that have not been factory-tested at 0.8 PF will not be acceptable.
  - 2. Voltage regulation shall be plus or minus 0.5 percent of rated voltage for any constant load between no load and rated load. Random voltage variation with any steady load from no load to full load shall not exceed plus or minus 0.5 percent.
  - 3. Frequency regulation shall be isochronous from steady state no load, to steady state rated load.
  - 4. Total Harmonic Distortion: The sum of AC voltage waveform harmonics, from no load to full linear load, shall not exceed 5% of rated voltage (L-N, L-L, L-L-L) and no single harmonic shall exceed 3% of rated voltage.
  - 5. The diesel engine-generator set shall be capable of single step load pick-up of 100% nameplate kW and power factor, less applicable de-rating factors, with the engine-generator set at operating temperature.

6. After an initial instantaneous voltage dip not to exceed 35 percent, the generator set shall be capable of sustaining a minimum of 90% of rated no-load voltage with the specified kVA load at near zero power factor applied to the generator set.
- C. AC Generator: AC generator, exciter, and voltage regulator shall be designed and manufactured by the engine-generator set manufacturer as a complete generator system.
1. The AC generator shall be synchronous, four-pole, 2/3 pitch, revolving field, drip-proof construction, single pre-lubricated sealed bearing, air-cooled by a direct-drive centrifugal blower fan, and directly connected to the engine with flexible drive disk(s). The stator shall have skewed lamination of insulated electrical-grade steel, two-thirds pitch windings. The rotor shall have amortisseur (damper) windings. The rotor shall be dynamically balanced. The exciter shall be brushless, three-phase, with full wave silicone diodes mounted on the rotating shaft and a surge suppressor connected in parallel with the field winding.
  2. All insulation system components shall meet NEMA MG1 standard temperature limits for Class H insulation system. Actual temperature rise measured by resistance method at full load shall not exceed 125 degrees Centigrade.
  3. The generator shall be capable of delivering rated output (kVA) at rated frequency and power factor, at any voltage not more than 5 percent above or below rated voltage.
  4. A permanent magnet generator (PMG) shall provide excitation power to the automatic voltage regulator for immunity from voltage distortion caused by non-linear SCR controlled loads on the generator. The PMG shall sustain main field excitation power for optimum motor starting and to sustain short circuit current at approximately 300% of rated current for approximately 10 seconds.
- D. Engine-Generator Set Control: The generator set shall be provided with a microprocessor based control system which is designed to provide automatic starting, monitoring, and control functions for the generator set. The control system shall also be designed to allow local monitoring and control of the generator set, and remote monitoring and control as described in this specification.

The control shall be mounted on the generator set. The control shall be vibration isolated and prototype tested to verify the durability of all components in the system under the vibration conditions encountered.

The control shall be UL508 listed, CSA282-M1989 certified, and meet IEC8528 part 4. All switches, lamps and meters shall be oil-tight and dust-tight, and the enclosure door shall be gasketed. There shall be no exposed points in the control (with the door open) that operate in excess of 50 volts. The controls shall meet or exceed the requirements of Mil-Std 461C part 9, and IEC Std 801.2, 801.3, and 801.5 for susceptibility, conducted, and radiated electromagnetic emissions. The entire control shall be tested and meet the requirements of IEEE587 for voltage surge resistance.

The generator set mounted control shall include the following features and functions:

1. Three position control switch labeled RUN/OFF/AUTO: In the RUN position the generator set shall automatically start, and accelerate to rated speed and voltage. In the OFF position the generator set shall immediately stop, bypassing all time delays. In the AUTO position the generator set shall be ready to accept a signal from a remote device to start and accelerate to rated speed and voltage.
2. Push-button EMERGENCY STOP switch: Depressing the emergency stop switch shall cause the generator set to immediately shut down, and be locked out from automatic restarting.
3. Push-button RESET switch: The RESET switch shall be used to clear a fault and allow restarting the generator set after it has shut down for any fault condition.
4. Push-button PANEL LAMP switch: Depressing the panel lamp switch shall cause the entire panel to be lighted with DC control power. The panel lamps shall automatically be switched off 10 minutes after the switch is depressed, or after the switch is depressed a second time.
5. Generator Set AC Output Metering: The generator set shall be provided with a metering set including the following features and functions:
  - a. 2.5-inch, 90 degree scale analog voltmeter, ammeter, frequency meter, and kilowatt (KW) meter. These meters shall be provided with a phase select switch and an indicating lamp for upper and lower scale on the meters. Ammeter and KW meter scales shall be color coded in the following fashion: readings from 0-90% of generator set standby rating: green; readings from 90-100% of standby rating: amber; readings in excess of 100%: red.
  - b. Digital metering set, 0.5% accuracy, to indicate generator RMS voltage and current, frequency, output current, output KW, KW-hours, and power factor. Generator output voltage shall be available in line-to-line and line-to-neutral voltages, and shall display all three phase voltages (line to neutral or line to line) simultaneously.

6. Generator Set Alarm and Status Message Display: The generator set shall be provided with alarm and status indicating lamps to indicate non-automatic generator status, and existing alarm and shutdown conditions. The lamps shall be high-intensity LED type. The lamp condition shall be clearly apparent under bright room lighting conditions. The control panel shall be mounted on the unit including the following:

a. Status:

1. Run-off-automatic control switch (manual-off-remote)
2. Water temperature indicator, digital type
3. Lube oil temperature indicator, digital type
4. Lube oil pressure indicator (digital type)
5. Digital power factor meter
6. Digital ammeter
7. Digital kilowatt hour meter
8. Digital voltmeter line-to-line and line-to-neutral
9. Voltmeter/ammeter phase selector switch
10. Panel light and switch
11. Menu switch
12. Digital elapsed timer meter
13. Digital frequency meter
14. Voltage regulator
15. Voltage adjuster rheostat
16. Emergency stop switch
17. Digital percent of load meter
18. Digital kW meter
19. Engine rpms
20. DC battery voltage
21. Engine shutdown counter
22. Engine running hours

- b. Alarm indication shall be provided in the control panel for each of the following malfunctions/alarms. Items one (1) through thirteen (13) shall shut down the generator:

1. Emergency stop
2. Fail to crank
3. High AC voltage
4. High water temperature
5. Low AC voltage
6. Low coolant level
7. Low oil pressure
8. Over-crank
9. Over current
10. Over-speed
11. Short circuit
12. Under-frequency
13. Low fuel shutdown
14. Low battery voltage

15. Low fuel alarm
  16. Low coolant temperature
  17. Fuel tank rupture
  18. Anticipatory-high water temperature
  19. Anticipatory-low oil pressure
  20. Generator circuit breaker tripped
  21. Switch in off position
  22. High battery voltage
  23. Lamp test and horn silence switch
  24. Generator power available
- c. The control panel shall be provided with four (4) dry type form (C) (n.o./n.c.) alarm contacts, one for each of the following conditions.
1. Generator running
  2. Generator shutdown failure (Items 1, 2, 3, 4, 5, 6, 7, 8, 9, 10, 11, 12, 13)
  3. Generator alarm (Items 14, 16, 17, 18, 19, 20, 21, 22)
  4. Low fuel alarm (Item 15)
- d. In addition, provisions shall be made for indication of two customer-specified alarm or shutdown conditions. The non-automatic indicating lamp shall be red, and shall flash to indicate that the generator set is not able to automatically respond to a command to start from a remote location.
7. The contacts specified previously, for bypassing the starting battery low voltage alarm relay during the starting period, shall be wired to terminals in this panel for interconnecting to the low voltage alarm relay in the battery charger. A fused 10 amp switched 24VDC power supply circuit shall be provided for customer use (DC power shall be available from this circuit whenever the generator set is running). Also, a fused 20 amp 24VDC power supply circuit shall be provided for customer use (DC power shall be available from this circuit at all times from the engine starting/control batteries).
8. Control Functions: The control system provided shall include a cycle cranking system, which allows for user selected crank time, rest time, and # of cycles. Initial settings shall be for 3 cranking periods of 15 seconds each, with a 15 second rest period between cranking periods.
- a. The control system shall include an idle mode control, which allows the engine to run in idle mode in the RUN position only. In this mode, the alternator excitation system shall be disabled.

- b. The control system shall include an engine governor control, which functions to provide steady state frequency regulation as noted elsewhere in this specification. The governor control shall include adjustments for gain, damping, and a ramping function to control engine speed and limit exhaust smoke while the unit is starting. The governor control shall be suitable for use in paralleling applications without component changes.
  - c. The control system shall include time delay start (adjustable 0-300 seconds) and time delay stop (adjustable 0-600 seconds) functions.
  - d. The control system shall include sender failure monitoring logic for speed sensing, oil pressure, and engine temperature which is capable of discriminating between failed sender or wiring components, and an actual failure conditions.
9. Alternator Control Functions: The generator set shall include an automatic voltage regulation system which is matched and prototype tested with the governing system provided. It shall be immune from misoperation due to load-induced voltage waveform distortion and provide a pulse width modulated output to the alternator exciter. The voltage regulation system shall be equipped with three-phase RMS sensing and shall control buildup of AC generator voltage to provide a linear rise and limit overshoot. The system shall include a torque-matching characteristic, which shall reduce output voltage in proportion to frequency below a threshold of 59 Hz. The voltage regulator shall include adjustments for gain, damping, and frequency roll-off. Adjustments shall be broad range, and made via digital raise-lower switches, with an alpha-numeric LED readout to indicate setting level. The voltage regulation system shall include provisions for reactive load sharing and electronic voltage matching for paralleling applications. Motorized voltage adjust pot is not acceptable for voltage matching.
- a. Controls shall be provided to monitor the output current of the generator set and initiate an alarm when load current exceeds 110% of the rated current of the generator set on any phase for more than 60 seconds. The controls shall shut down and lock out the generator set when output current level approaches the thermal damage point of the alternator.
  - b. Controls shall be provided to monitor the KW load on the generator set, and initiate an alarm condition when total load on the generator set exceeds the generator set rating for in excess of 5 seconds.
  - c. Controls shall include a load shed control, to operate a set of dry contacts (for use in shedding customer load devices) when the generator set is overloaded.
  - d. An AC over/under voltage monitoring system which responds only to true RMS voltage conditions shall be provided. The system shall initiate shutdown of the generator set when alternator output voltage exceeds 110% of the operator-set voltage level for more than 10 seconds, or with no intentional delay when voltage exceeds 130%. Under voltage shutdown shall occur when the output voltage of the alternator is less than 85% for more than 10 seconds.

- e. A battery monitoring system shall be provided which initiates alarms when the DC control and starting voltage is less than 25VDC or more than 32 VDC. During engine starting, the low voltage limit shall be disabled, and if DC voltage drops to less than 14.4 volts for more than two seconds a "weak battery" alarm shall be initiated.
  
- E. Engine: The engine shall be diesel fueled, direct injection, with forged steel crankshaft and connecting rods. The horsepower rating of the engine at its minimum tolerance level shall be sufficient to drive the alternator and all connected accessories. Two cycle engines are not acceptable. The engine shall be certified to US EPA Nonroad Source Emission Standards, 40 CFR 89, Tier 3. An electronic governor system shall provide automatic isochronous frequency regulation.
  - 1. Skid-mounted radiator and cooling system rated for full load operation in 122 degrees F (50 degrees C) ambient as measured at the generator air inlet. Radiator shall be provided with a duct adapter flange. The cooling system shall be filled with 50/50 ethylene glycol/water mixture by the equipment supplier. Rotating parts shall be guarded against accidental contact.
  
- F. Engine Accessory Equipment: The engine generator set shall include the engine accessories as follows:
  - 1. An electric starter(s) capable of three complete cranking cycles without overheating.
  - 2. Positive displacement, mechanical, full pressure, lubrication oil pump.
  - 3. Full flow lubrication oil filters with replaceable spin-on canister elements and dipstick oil level indicator.
  - 4. An engine driven, mechanical, positive displacement fuel pump. Fuel filter with replaceable spin-on canister element.
  - 5. Replaceable dry element air cleaner with restriction indicator.
  - 6. Flexible supply and return fuel lines.
  - 7. Engine mounted battery charging alternator, and solid-state voltage regulator.
  
- G. Base: The engine-generator set shall be mounted on a heavy-duty steel base to maintain proper alignment between components. The engine-generator set shall incorporate a battery tray with hold-down clamps within the base rails. Provisions for stub-up of electrical and fuel connections shall be within the footprint of the generator set base rails.
  
- H. Generator Set Auxiliary Equipment and Accessories:
  - 1. Engine-mounted, thermostatically controlled, water jacket heater. The heater shall be sized as recommended by the equipment supplier. Heater voltage shall be 120 VAC. Provide proper power supply circuits for the heater as required.

2. Vibration isolators, rubber dampener type, quantity as recommended by the generator set manufacturer.
3. Starting and Control Batteries: Starting batteries, lead-acid type, sized as recommended by the generator set manufacturer, shall be supplied for the generator set with battery cables and connectors.
4. Sub-base Fuel Storage Tank: Provide a dual-wall sub-base fuel storage tank for the generator set with sufficient capacity to run its associated generator at full load for twenty four (24) hours. The fuel tank shall be a standard product of the manufacturer of the engine-generator set. The tank shall be dual UL-listed, made of aluminized steel with welded construction, and pressure tested to 5 PSI. Tank shall be provided with a high and low fuel level switch and a rupture detection sensor. The sub-base tank shall include fuel level switches with normally open and normally closed contacts to indicate high and low level.
5. Exhaust Silencer: Provide critical grade silencer and engine exhaust system. Exhaust muffler to be sized as recommended by the generator set manufacturer. Silencer and exhaust shall include a rain cap and rain shield.

#### **16622.2.02 AUTOMATIC TRANSFER SWITCH**

- A. Provide a complete factory assembled transfer switch with the generator set, with electronic controls designed for surge voltage isolation, including voltage sensors on all phases of both sources, linear operator, permanently attached manual handles, positive mechanical and electrical interlocking, and mechanically held contacts.
- B. Automatic transfer switch must have an isolation “bypass feature” to manually switch to the generator in the event of a power outage, while at same time a failure of the transfer switch occurs.
- C. Automatic transfer switch shall be of the electrically-operated, mechanically-held type. The combination of the transfer switch and engine starting system specified above shall automatically start the engine-generator and transfer the load from the normal source to the emergency source when any phase of the normal source drops below seventy-five (75) percent of rated value, and shall automatically stop the engine-generator and restore the load to the normal source when all phases are ninety-seven (97) percent or more of rated voltage. System status shall be made at selector switch on generator control panel.
- D. Transfer switch shall have a NEMA 12 enclosure for indoor mounting. The access door shall be padlockable. Manual operating handles and all control switches shall be accessible to authorized personnel only, by opening the key-locked outer cabinet door.
- E. Transfer switch shall be built by a manufacturer regularly engaged in the production of UL 1008 listed equipment for at least five (5) years, and furnished and warranted by the manufacturer of the engine-generator to ensure one source of responsibility and compatibility for the entire emergency system.

- F. Transfer switch shall be quick-make, quick-break, double throw type, positively interlocked mechanically and electrically to prevent simultaneous closing, either by accident or intent. Speed of opening and closing shall be independent of any manual operation.
- G. Provide an adjustable 0-30 second time delay in the starting circuit (initially set at 1 second), and an adjustable 0-30 minute delay on re-transfer with 5-minute unloaded period to permit the engine to cool down (initially set at 30 minutes). In addition, an adjustable programmed transition time delay shall be provided to assure delay on re-transfer to the utility (normal) supply. Only upon achievement of proper decay of motor voltages and stresses shall the re-transfer to the normal source be initiated by the transfer switch controls.
- H. Transfer switch shall include built-in status LED's to assist in determining malfunctioning in the equipment. Cabinet door shall include indicating lights for normal and emergency positions, and TEST, NORMAL, MANUAL key-operated selector switch.
- I. Transfer switch shall include (4) Form C auxiliary contacts (120 Volts, 5 Amperes) for OWNER use.
- J. Transfer switch to include an exercise clock, to set the day, time, and duration of generator set exercise/test period. Provide a with/without load selector switch for the exercise period.
- K. Transfer switch shall include a battery charger for charging the generator's on-board batteries.

### **16622.2.03 LOAD BANK**

- A. Furnish and install a permanent type outdoor weatherproof load bank on concrete pad, consisting of heavy gauge steel structure, corrosion resistant nickel chromium wire resistor elements, integral control transformer and protective louvers. Load bank shall have 100% of the KW capacity of the generator and shall include controls for the blocks of load as indicated below and integral code required disconnect.
- B. Contactors shall be located within the load bank housing and shall be of the electrically held type for each of the individual sections of resistor elements. Contactors shall be controlled in groups and be selected at the indoor control panel. In the Automatic and Manual Exercising modes, blocks of loads shall automatically be brought on-line in step fashion until generator is fully loaded by the load bank and/or station load. Increasing load shall not stall the generator.
- C. A separate indoor control panel in a NEMA 4X enclosure shall be provided in the Control Building with toggle switch controls and pilot light for each of the blocks of load indicated, "ON" and "OFF" master control with pilot light, cooling fan "RUN" and "FAILURE" indications, Loss of Normal Source indicator, transfer switch by-pass control and pilot lights and alarms required by UL approvals.
- D. Load bank shall be interlocked, through the controls, with the automatic transfer switch so that in the event of a power failure during a test run using the Load Bank, the Load Bank will be disconnected. In addition, a by-pass switch for this interlock shall be included to allow the load bank to supplement the normal building load, if desired.

- E. A self-contained ventilating fan shall provide sufficient airflow for satisfactory operation of the load bank at rated load in the location indicated. A differential pressure switch and controls shall automatically disconnect the load bank elements if insufficient airflow does not provide adequate ventilation. Fan motor shall have a starter and disconnect included in the load bank housing. Energizing the load bank shall automatically operate the fan.
- F. Load bank shall be Simplex Neptune series, AVTRON, or approved equal.

## **PART 3 - EXECUTION**

### **16622.3.01 INSTALLATION**

- A. The equipment will be installed in accordance with the final submittals, and will comply with applicable state and local codes, as required by the authority having jurisdiction. The equipment will be installed in accordance with manufacturer's instructions, and instructions included in the listing or labeling of UL-listed products.
- B. Installation of equipment will include furnishing and installing all interconnecting wiring between all major equipment provided for the on-site power system.
- C. The generator will be installed on a concrete pad. Equipment will be permanently fastened to the pad in accordance with the manufacturer's instructions.
- D. Equipment shall be initially started and operated by a representative of the manufacturer.
- E. All equipment will be physically inspected for damage. Scratches and other damage shall be repaired prior to final system testing.

### **16622.3.02 FACTORY TESTS**

- A. Generator set factory production tests on the equipment to be shipped shall be performed at rated load and rated PF. These tests shall include run at full load, maximum power, voltage regulation, transient and steady-state governing, single-step load pickup, and safety shutdowns. Provide a factory-certified test record of the production testing to the ENGINEER for review, prior to shipment.
- B. Transfer Equipment Factory Tests: Transfer switch shall be factory tested before shipment. Factory tests to include a complete functional test of the transfer switch controls, including calibration of the voltage sensors. Provide a factory-certified test record of the production testing to the ENGINEER for review, prior to shipment.

### 16622.3.03 ON-SITE ACCEPTANCE TEST

- A. Prior to acceptance of the installation, equipment shall be tested to show it is free of any defects and will start automatically. On completion of the installation, a factory trained dealer service representative shall perform start-up. The manufacturer shall be responsible for providing at CONTRACTOR's cost the services of all the associated trades required for acceptance test of the complete generator system including ATS and load bank.
- B. All lubricants and batteries to accomplish acceptance testing shall be provided by the manufacturer.
- C. The manufacturer shall provide four hours of site testing at 100% full load (KW). Provide full testing of entire system including automatic transfer features, safety shutdowns, etc. Record in 20 minute intervals during four hour test the following values:
  - 1. Kilowatts
  - 2. Amperes of each phase
  - 3. Voltage of each phase
  - 4. Coolant temperature
  - 5. Room temperature
  - 6. Frequency
  - 7. Oil pressure
  - 8. Fuel consumption
- D. Test alarm and shutdown circuits by simulating conditions.
- E. Provide an additional four (4) hours of pump station load testing for the generator in addition to the load bank testing listed above. Record same parameters as listed above. Start pumps/ loads individually and all at once, a total of five times in fifteen (15) minute intervals. Coordinate with OWNER when starting pumps/loads.
- F. Provide during field testing, a minimum of 100% "block loading" test applied in one step to the generator set, a minimum of six times, as well as 25%, 50% and 75% load testing of 20 minute durations. Provide four (4) copies of the service representative's typewritten report. To be included as part of the O&M Manuals.
- G. CONTRACTOR shall notify the ENGINEER ten (10) working days prior to start of field testing. The ENGINEER and the OWNER shall witness all field testing.
- H. Test/demonstrate each alarm/protective feature/malfunction that would shut down the engine generator system.
- I. CONTRACTOR will fill the generator fuel tank before and after the field testing, so that OWNER is left with a full tank upon completion of the testing.
- J. Test all SCADA and Dialer alarms.

#### **16622.3.04 ON-SITE TRAINING**

The equipment supplier/manufacturer shall provide training for the OWNER's personnel at the site after installation and acceptance testing. This shall cover operation and maintenance of the equipment provided. The training program shall be not less than four (4) hours in duration. Training shall be coordinated with the OWNER and ENGINEER in advance.

**END OF SECTION**

## **APPENDIX A**

### **LIST OF BUCKS COUNTY WATER & SEWER AUTHORITY OWNED WATER AND SANITARY SEWER SYSTEMS**

(Listed Alphabetically)

#### **LOCATED IN BUCKS COUNTY**

Bedminster Township (portions of Sewer)  
Bensalem Township (Sewer)  
Bristol Borough (Sewer)  
Buckingham Township (portions of Sewer)  
Doylestown Borough (Sewer)  
Doylestown Township (Sewer)  
Langhorne Borough (Sewer and Water)  
Langhorne Manor Borough (Water)  
Lower Southampton Township (Water)  
Middletown Township (portions of Sewer and Water)  
New Britain Borough (Sewer)  
New Hope Borough (Sewer and Water)  
Pennel Borough (Water)  
Plumstead Township (Sewer)  
Richlandtown Borough (Sewer)  
Richland Township (Sewer)  
Solebury Township (portions of Sewer and Water)  
Warrington Township (Sewer)

#### **LOCATED IN MONTGOMERY COUNTY**

Springfield Township (Sewer)  
Upper Dublin Township (Sewer)

#### **LOCATED IN CHESTER COUNTY**

West Vincent Township (portions of Sewer and Water)  
Birmingham Township (Sewer)

**APPENDIX B**

**MAINTENANCE BOND**

**KNOW ALL MEN**, that we, \_\_\_\_\_ as Principal,  
and \_\_\_\_\_

as Surety, are held and firmly bound unto Bucks County Water and Sewer Authority and its successors  
and assigns (hereinafter called the Obligee), in several just sums of

\_\_\_\_\_ Dollars  
(\$ \_\_\_\_\_) for maintenance as specified below:

in lawful money of the United States, for payment of which sum truly to be made, we bind ourselves  
and each of our respective heirs, personal representatives, successors and assigns, jointly and severally,  
firmly by these presents, this \_\_\_\_\_ day of \_\_\_\_\_, 20 \_\_\_\_\_.

**WHEREAS**, the Principal has entered into a written agreement with the Obligee, dated as of  
\_\_\_\_\_, for performance of \_\_\_\_\_ in  
connection with which Agreement, together with the plans and documents therefore, and such alterations  
as may be made in such plans and documents as therein provided, are hereby made a part hereof as fully  
as if set out herein, and shall together be hereinafter referred to as the "Project"; and it was a condition of  
the Project that this bond be furnished.

**THEREFORE, THE CONDITIONS OF THE ABOVE OBLIGATIONS ARE:**

That, if the Principal shall remedy without cost to the Obligee any defects which may develop  
during a period of one (1) year from the date of completion and acceptance of the work by the OWNER  
performed under the Project, provided that such defects in the judgment of the Obligee or its successor,  
are caused by defective or inferior materials or workmanship, then this part of the obligation shall be  
void, but otherwise it shall remain in full force. However, the Principal agrees that the foregoing one-  
year limitation shall apply to the Surety only and shall not relieve the Principal of any liability  
otherwise provided by law or by the Project's Documents.

The Surety, for value received, hereby agrees that no change, extension of time, alterations or additions to the terms of any of the Documents or to the work to be performed there under, nor any forbearance by either the Obligee or the Principal to the other, shall in any way affect its obligation in this bond, and it hereby waives notice of any such change, extension of time, alteration or addition.

Both Principal and Surety acknowledge that all references herein to the Principal, in singular form, shall include the plural, as may be appropriate to the Principal.

**IN WITNESS WHEREOF**, the Principal and Surety, intending to be legally bound, have executed this bond the day and year aforementioned.

\_\_\_\_\_  
Principal

By: \_\_\_\_\_  
Attorney-in-Fact  
(Surety)

## APPENDIX C

### BCWSA SANITARY SEWER SYSTEM REVIEW/DEDICATION PROCESS

1. Pre-application Meeting: The purpose of this meeting is to familiarize the AUTHORITY (BCWSA) with the site location and general scope of work for the project, and to acquaint the DEVELOPER (applicant) with the BCWSA review process. At this meeting, the applicant will provide an estimate of EDUs required for the project, or sufficient information regarding the proposed uses for the project, so that BCWSA can estimate the anticipated tapping fees to be paid and the initial professional services fees needed to begin the design review process. BCWSA will also attempt to identify existing sewer facilities that will need to be constructed or upgraded as part of this project (if any) to accommodate the flows from the project. **This step is strongly recommended so that an applicant and/or design consultant can optimize the design review process and avoid multiple resubmittals and reviews.**
2. Professional Services Agreement: This Agreement is for the purpose of funding the services of BCWSA and its professionals to review the project and prepare the necessary service Agreement(s). The review and approval of a sewage planning module submittal is not included in this Agreement unless the DEVELOPER executes a Reservation of Capacity Agreement (discussed below) and pays for associated tapping fees in part or in full.
  - a. Fees for professional services during the planning module review, design review, and Agreement preparation process will be based on estimates provided by the AUTHORITY based on past experience with similar projects. Depending on the pace of design compliance with AUTHORITY standards and review comments, these funds may need to be replenished.
3. Reservation of Capacity Agreement: This Agreement reserves capacity (EDUs) for the DEVELOPER's project and allows the DEP sewage planning module to be executed by BCWSA. Payment of tapping fees is required at the time of Agreement execution. Planning module reviews cannot be processed without execution of this Agreement and payment of the required tapping fees.
  - a. Tapping fees should be paid in full at the time of execution of the Reservation of Capacity Agreement. If deemed appropriate by the AUTHORITY, a ten percent (10%) deposit towards the total tapping fee may instead be provided along with signed correspondence by the DEVELOPER to PADEP and the Municipality, noting the planning module will be rescinded if the remaining balance is not paid within a two (2) year period. The remaining ninety percent (90%) balance will be required at the time of execution of the Sewer Service Agreement.
  - b. Debt service payment for a two year period will be required in full at the time of execution of the Reservation of Capacity Agreement. Debt Service payment is non-refundable.

- c. Purchase of sewer capacity should be in accordance with the latest version of the Sale of Equivalent Dwelling Units (EDUs) of Sewer Capacity Policy, a copy of which will be included as an exhibit to the Reservation of Capacity Agreement.
4. Sewer Service Agreement: This Agreement outlines the terms and conditions under which the AUTHORITY agrees to provide public sanitary sewage service for the project. The DEVELOPER agrees to all terms and conditions required by the AUTHORITY, including the payment of tapping fees and debt service (if not previously paid in full under the Reservation of Capacity Agreement), providing a Certificate of Insurance outlining minimum insurance requirements, and the construction, inspection, and testing of all sanitary sewer facilities in accordance with the AUTHORITY's Standard Specifications. The Agreement also requires payment of professional services fees, as well as an outline of the requirements for project dedication (if applicable) after all construction is completed.
  - a. Professional services during the construction and dedication process will be based on estimates provided by the AUTHORITY's professionals based on past experience with similar projects. Depending on the pace of construction and dedication, these funds may need to be replenished.
  - b. A Certificate of Insurance shall be provided with BCWSA and the AUTHORITY's Engineer as Additional Insureds. Limits are shown in Section 01010.
5. Sewer Facilities Escrow Agreement: This Agreement establishes a construction escrow for the project, typically in the amount of the sanitary sewer improvements plus contingency, as determined by the AUTHORITY's Engineer. This Agreement is primarily used when facilities are being dedicated to the AUTHORITY, if the AUTHORITY is named as a co-permittee on an agency permit, and/or if financial security throughout construction is deemed necessary by the AUTHORITY. In the event of a default by the DEVELOPER of its obligations as outlined in the Sewer Service Agreement prior to dedication or project closeout, the AUTHORITY may elect to draw upon the financial security to the extent the AUTHORITY deems appropriate, to complete the improvements, eliminate dangerous or unsatisfactory conditions, or similar as it decides at AUTHORITY's sole discretion. The security is typically provided in the form of a cash escrow, performance bond, or letter of credit and is held through dedication or project closeout. As work progresses, the DEVELOPER may request reductions to the construction escrow, although a 10% retainage is held until acceptance of dedication by the AUTHORITY or project closeout.
6. Sewer Service – No Improvements Agreement: This Agreement is a substitute for the Sewer Service Agreement, and is typically used for projects involving a lateral connection that will remain private, instances that require three (3) EDUs or less of sewage capacity, and/or at the sole discretion of the AUTHORITY.

This Agreement outlines the terms and conditions under which the AUTHORITY agrees to provide public sanitary sewage service for the project. The DEVELOPER agrees to all terms and conditions required by the AUTHORITY, including the payment of tapping fees and debt service, providing a Certificate of Insurance outlining minimum insurance requirements, and the construction, inspection, and testing of all sanitary sewer facilities in accordance with the AUTHORITY's Standard Specifications. The Agreement also requires payment of professional services fees associated with construction and project closeout.

7. Dedication and/or Project Closeout: The review process for offering facilities for dedication to the AUTHORITY, or the closeout of the project if facilities are to remain private, should occur as soon as practical following the completion of the construction and testing of facilities. All punch list items should be addressed to the satisfaction of the AUTHORITY Engineer.
  - a. Requirements for dedications are outlined in the Sewer Service Agreement, and typically include the following:
    - 1) The review and approval of as-built drawings by the AUTHORITY's Engineer.
    - 2) The review and approval by the AUTHORITY's Engineer, of a summary of the facilities to be dedicated (along with the cost associated to furnish and install the facilities).
    - 3) The review and approval of title insurance and a maintenance bond by the AUTHORITY's Solicitor.
    - 4) The preparation or review and approval by the AUTHORITY's Solicitor, of the Deed of Easement (if easements are being conveyed), Bill of Sale, and/or Deed of Dedication for the facilities being dedicated.
    - 5) All outstanding charges for professional and administrative services will need to be paid before final dedication is granted and final construction escrow is released.
  - b. In cases where facilities will remain private and not dedicated to the AUTHORITY, requirements for project closeout should be discussed with the AUTHORITY and/or their Engineer on a project specific basis. Requirements typically include the review and approval of as-built drawings by the AUTHORITY's Engineer, and payment of any outstanding charges for professional and administrative services related to the project.
    - 1) All non-dedicated systems will require permanent metering/measuring devices to ensure accurate usage data for billing.

## APPENDIX D

### BCWSA WATER SYSTEM REVIEW/DEDICATION PROCESS

1. Pre-application Meeting: The purpose of this meeting is to familiarize BCWSA with the site location and general scope of work for the project, and to acquaint the applicant with the BCWSA review process. At this meeting, the applicant will provide an estimate of EDUs required for the project, or sufficient information regarding the proposed uses for the project, so that BCWSA can estimate the anticipated tapping fees to be paid and the initial professional services fees needed to begin the design review process. BCWSA will also attempt to identify existing water facilities that will need to be constructed or upgraded as part of this project (if any) to accommodate additional flows and/or pressure to serve the project. **This step is strongly recommended so that an applicant and/or design consultant can optimize the design review process and avoid multiple resubmittals and reviews.**
2. Professional Services Agreement: This Agreement is for the purpose of funding the services of BCWSA and its professionals to review the project and prepare the necessary service Agreement(s).
  - a. Fees for professional services during the planning module review, design review, and Agreement preparation process will be based on estimates provided by the AUTHORITY based on past experience with similar projects. Depending on the pace of design compliance with AUTHORITY standards and review comments, these funds may need to be replenished.
3. Water Service Agreement: This Agreement outlines the terms and conditions under which the AUTHORITY agrees to provide public water service for the project. The DEVELOPER agrees to all terms and conditions required by the AUTHORITY, including the payment of tapping fees and debt service, payment for purchase of water meters (domestic and/or fire service) as determined by the AUTHORITY's Engineer, providing a Certificate of Insurance outlining minimum insurance requirements, and the construction, inspection, and testing of all water facilities in accordance with the AUTHORITY's Standard Specifications. The Agreement also requires payment of professional services fees, as well as an outline of the requirements for project dedication (if applicable) after all construction is completed.
  - a. Professional services during the construction and dedication process will be based on estimates provided by the AUTHORITY's professionals based on past experience with similar projects. Depending on the pace of construction and dedication, these funds may need to be replenished.
  - b. A Certificate of Insurance shall be provided with BCWSA and the AUTHORITY's Engineer as Additional Insureds. Limits are shown in Section 01010.

4. Water Facilities Escrow Agreement: This Agreement establishes a construction escrow for the project, typically in the amount of the water facilities improvements plus contingency, as determined by the AUTHORITY's Engineer. This Agreement is primarily used when facilities are being dedicated to the AUTHORITY, if the AUTHORITY is named as a co-permittee on an agency permit, and/or if financial security throughout construction is deemed necessary by the AUTHORITY. In the event of a default by the DEVELOPER of its obligations as outlined in the Water Service Agreement prior to dedication or project closeout, the AUTHORITY may elect to draw upon the financial security to the extent the AUTHORITY deems appropriate, to complete the improvements, eliminate dangerous or unsatisfactory conditions, or similar as it decides at AUTHORITY's sole discretion. The security is typically provided in the form of a cash escrow, performance bond, or letter of credit and is held through dedication or project closeout. As work progresses, the DEVELOPER may request reductions to the construction escrow, although a 10% retainage is held until acceptance of dedication by the AUTHORITY or project closeout.
5. Water Service – No Improvements Agreement: This Agreement is a substitute for the Water Service Agreement, and is typically used for projects involving a water service connection that will remain private, instances that require three (3) EDUs or less of water capacity, and/or at the sole discretion of the AUTHORITY.

This Agreement outlines the terms and conditions under which the AUTHORITY agrees to provide public water service for the project. The DEVELOPER agrees to all terms and conditions required by the AUTHORITY, including the payment of tapping fees and debt service, payment for purchase of water meters (domestic and/or fire service) as determined by the AUTHORITY's Engineer, providing a Certificate of Insurance outlining minimum insurance requirements, and the construction, inspection, and testing of all water facilities in accordance with the AUTHORITY's Standard Specifications. The Agreement also requires payment of professional services fees associated with construction and project closeout.

6. Dedication and/or Project Closeout: The review process for offering of facilities for dedication to the AUTHORITY, or the closeout of the project if facilities are to remain private, should occur as soon as practical following the completion of the construction and testing of facilities. All punch list items should be addressed to the satisfaction of the AUTHORITY Engineer.
  - a. Requirements for dedications are outlined in the Water Service Agreement, and typically include the following:
    - 1) The review and approval of as-built drawings by the AUTHORITY's Engineer.
    - 2) The review and approval by the AUTHORITY's Engineer of a summary of the facilities to be dedicated (along with the cost associated to furnish and install the facilities).
    - 3) The review and approval of title insurance and a maintenance bond by the AUTHORITY's Solicitor.

- 4) The preparation or review and approval by the AUTHORITY's Solicitor of the Deed of Easement (if easements are being conveyed), Bill of Sale, and/or Deed of Dedication for the facilities being dedicated.
  - 5) All outstanding charges for professional and administrative services will need to be paid before final dedication is granted and final construction escrow is released.
- b. In cases where facilities will remain private and not be dedicated to the AUTHORITY, requirements for project closeout should be discussed with the AUTHORITY and/or their Engineer on a project specific basis. Requirements typically include the review and approval of as-built drawings by the AUTHORITY's Engineer, and payment of any outstanding charges for professional and administrative services related to the project.

**NOTES:**

1. THE DEPTH OF THE INVERT CHANNEL SHALL BE EQUAL TO 3/4 OF THE DIAMETER OF THE SEWER.
2. THE SHELF SHALL SLOPE TOWARD THE INVERT CHANNEL AT A RATE OF 1" PER FOOT.
3. TYPE "B" MANHOLES (SHALLOW TYPE) TO BE PROVIDED WHERE REQUIRED BY DEPTH CONDITIONS. ALL OTHER MANHOLES TO BE TYPE "A".
4. FOR MANHOLES HAVING 5' DIA. AND 6' DIA. BASE, REDUCTION IN DIAMETER TO 4' SHALL START AT THE FIRST JOINT ABOVE THE UPPERMOST PIPE CONNECTION TO WALL, WHERE DEPTH IS SUFFICIENT.
5. ALL MANHOLE FRAMES SHALL BE BOLTED TO THE CONE SECTION OR CONCRETE SLAB WITH (4)-3/4" DIA. BOLTS WITH WASHERS AND NUTS. BOLTS TO BE AT 90° ON THE BOLT CIRCLE.
6. SEE THE SPECIFICATIONS FOR LENGTH OF PIPE CONNECTIONS TO MANHOLES.
7. ALL CONCRETE SHALL BE 4000 PSI MINIMUM.
8. ENTIRE OUTSIDE SURFACE OF MANHOLE SHALL RECEIVE TWO COATS OF BITUMINOUS COATING, COAL TAR EPOXY, OR APPROVED EQUAL.
9. INSTALL DOUBLE RING OF PLASTIC BUTYL JOINT SEALANT BETWEEN ALL SECTIONS AND UNDER FRAME.
10. MANHOLE CONSTRUCTION SHALL BE IN ACCORDANCE WITH ASTM C478.

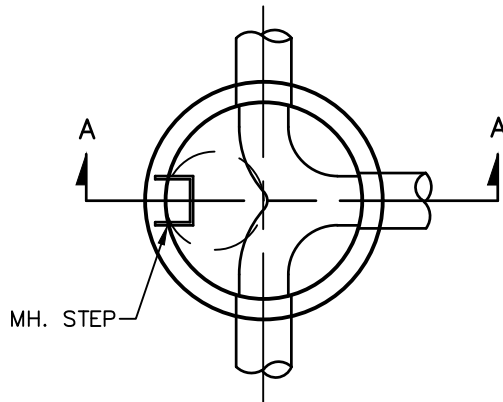

**PLAN VIEW**

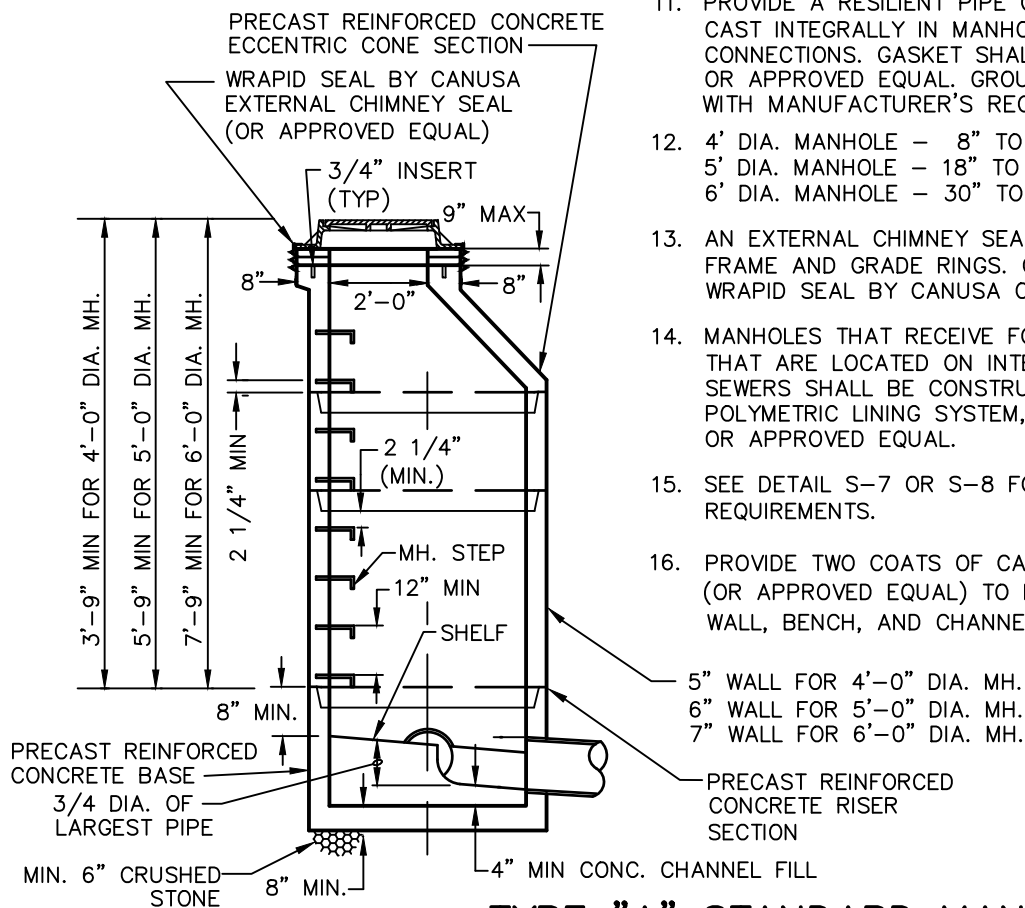

**SECTION A-A**

11. PROVIDE A RESILIENT PIPE CONNECTION GASKET CAST INTEGRALLY IN MANHOLE WALL AT ALL PIPE CONNECTIONS. GASKET SHALL BE A-LOK CONNECTOR, OR APPROVED EQUAL. GROUT IN ACCORDANCE WITH MANUFACTURER'S RECOMMENDATIONS.
12. 4' DIA. MANHOLE - 8" TO 16" PIPES  
5' DIA. MANHOLE - 18" TO 27" PIPES  
6' DIA. MANHOLE - 30" TO 48" PIPES
13. AN EXTERNAL CHIMNEY SEAL SHALL BE INSTALLED OVER FRAME AND GRADE RINGS. CHIMNEY SEAL SHALL BE WRAPID SEAL BY CANUSA OR APPROVED EQUAL.
14. MANHOLES THAT RECEIVE FORCE MAIN DISCHARGE OR THAT ARE LOCATED ON INTERCEPTORS OR TRUNK SEWERS SHALL BE CONSTRUCTED WITH A SPRAY-ON POLYMERIC LINING SYSTEM, SPECTRASHIELD, OBIC, OR APPROVED EQUAL.
15. SEE DETAIL S-7 OR S-8 FOR MANHOLE STEP REQUIREMENTS.
16. PROVIDE TWO COATS OF CARBOLINE CARBOGUARD 890 (OR APPROVED EQUAL) TO INTERIOR LOWER SECTION, WALL, BENCH, AND CHANNEL (WHITE EPOXY).

5" WALL FOR 4'-0" DIA. MH.  
6" WALL FOR 5'-0" DIA. MH.  
7" WALL FOR 6'-0" DIA. MH.

PRECAST REINFORCED CONCRETE RISER SECTION

**TYPE "A" STANDARD MANHOLE**

NTS

**BUCKS COUNTY WATER & SEWER AUTHORITY**

DWG. BY: TSB	CKD. BY:	TYPE "A" STANDARD MANHOLE
DATE: 7-24-19	SCALE: None	
REVISION	DATE	STANDARD DETAIL S-1
KTI	4/6/22	

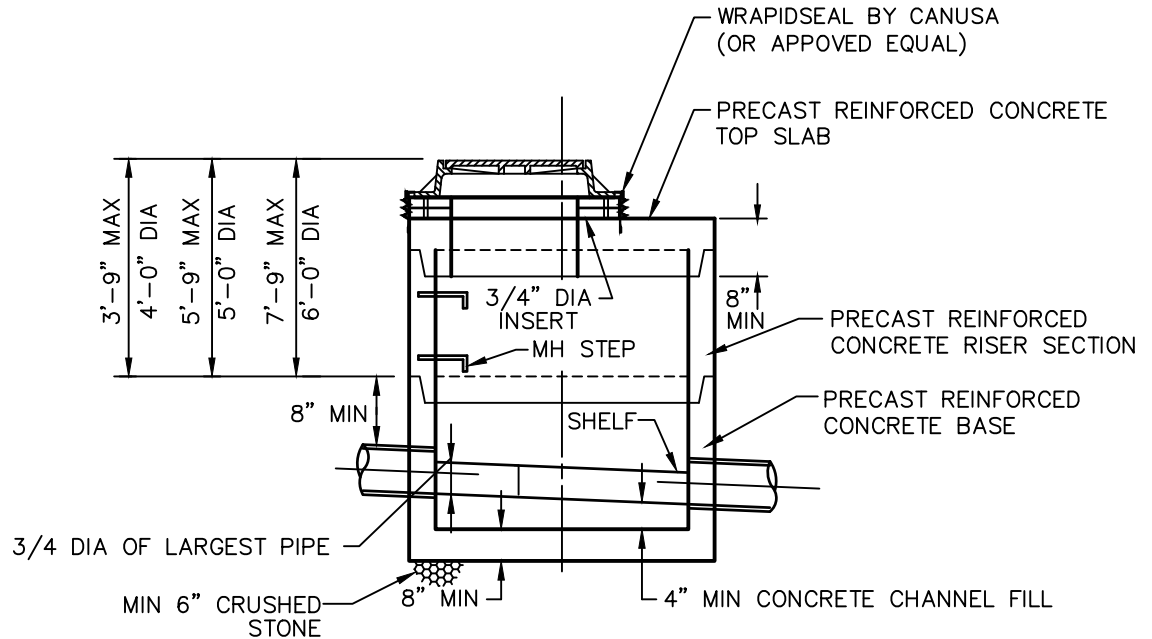

**NOTES:**

1. THE DEPTH OF THE INVERT CHANNEL SHALL BE EQUAL TO 3/4 OF THE DIAMETER OF THE SEWER.
2. THE SHELF SHALL SLOPE TOWARD THE INVERT CHANNEL AT A RATE OF 1" PER FOOT.
3. TYPE "B" MANHOLES (SHALLOW TYPE) TO BE PROVIDED WHERE REQUIRED BY DEPTH CONDITIONS. ALL OTHER MANHOLES TO BE TYPE "A".
4. FOR MANHOLES HAVING 5' DIA AND 6' DIA BASE, REDUCTION IN DIAMETER TO 4' SHALL START AT THE FIRST JOINT ABOVE THE UPPERMOST PIPE CONNECTION TO WALL, WHERE DEPTH IS SUFFICIENT.
5. ALL MANHOLE FRAMES SHALL BE BOLTED TO THE CONE SECTION OR CONCRETE SLAB WITH (4) - 3/4" DIA BOLTS WITH WASHERS AND NUTS. BOLTS TO BE AT 90° ON THE BOLT CIRCLE.
6. SEE THE SPECIFICATIONS FOR LENGTH OF PIPE CONNECTIONS TO MANHOLES.
7. ALL CONCRETE SHALL BE 4000 PSI MINIMUM.
8. ENTIRE OUTSIDE SURFACE OF MANHOLE SHALL RECEIVE TWO COATS OF BITUMINOUS COATING, COAL TAR EPOXY OR APPROVED EQUAL.
9. INSTALL DOUBLE RING OF BUTYL JOINT SEALANT BETWEEN ALL SECTIONS AND UNDER FRAME.
10. MANHOLE CONSTRUCTION SHALL BE IN ACCORDANCE WITH ASTM C478.
11. PROVIDE A RESILIENT PIPE CONNECTION GASKET CAST INTEGRALLY IN MANHOLE WALL AT ALL PIPE CONNECTIONS. GASKET SHALL BE A-LOK CONNECTOR, OR APPROVED EQUAL. GROUT IN ACCORDANCE WITH MANUFACTURER'S RECOMMENDATIONS.
12. 4' DIA MANHOLE - 8" TO 16" PIPES  
5' DIA MANHOLE - 18" TO 27" PIPES  
6' DIA MANHOLE - 30" TO 48" PIPES
13. AN EXTERNAL CHIMNEY SEAL SHALL BE INSTALLED OVER FRAME AND GRADE RINGS. CHIMNEY SEAL SHALL BE WRAPID SEAL BY CANUSA OR APPROVED EQUAL.
14. MANHOLES THAT RECEIVE FORCE MAIN DISCHARGE OR THAT ARE LOCATED ON INTERCEPTORS OR TRUNK SEWERS SHALL BE CONSTRUCTED WITH A SPRAY-ON POLYMERIC LINING SYSTEM, SPECTRASHIELD, OBIC, OR APPROVED EQUAL.
15. SEE DETAIL S-7 OR S-8 FOR MANHOLE STEP REQUIREMENTS.
16. PROVIDE TWO COATS OF CARBOLINE CARBOGUARD 890 (OR APPROVED EQUAL) TO INTERIOR LOWER SECTION, WALL, BENCH, AND CHANNEL (WHITE EPOXY).

**TYPE "B" SHALLOW MANHOLE**

NTS

BUCKS COUNTY WATER & SEWER AUTHORITY			
DWG. BY: TSB	CKD. BY:	TYPE "B" SHALLOW MANHOLE	
DATE: 7-24-19	SCALE: None		
REVISION	DATE		
KTI	4/6/22	STANDARD DETAIL	S-2

S:\mydocs\BCWSA Standard Detail Revisions\BCW-A\SPEC\SBCW-A.DWG Nov 25, 2019 2:52pm

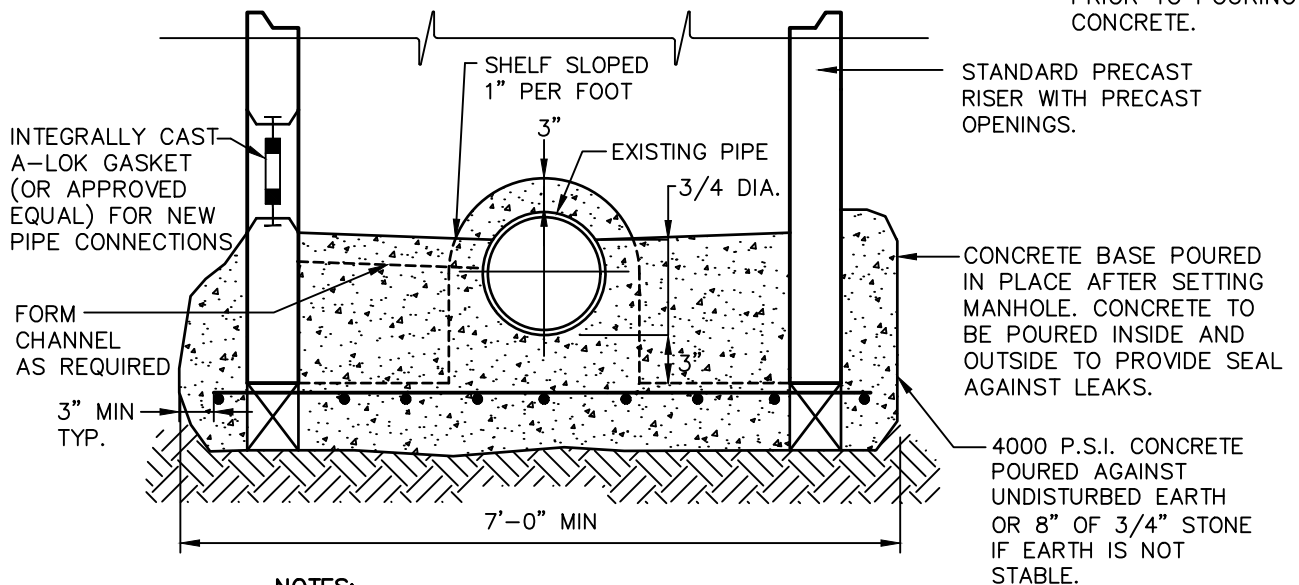
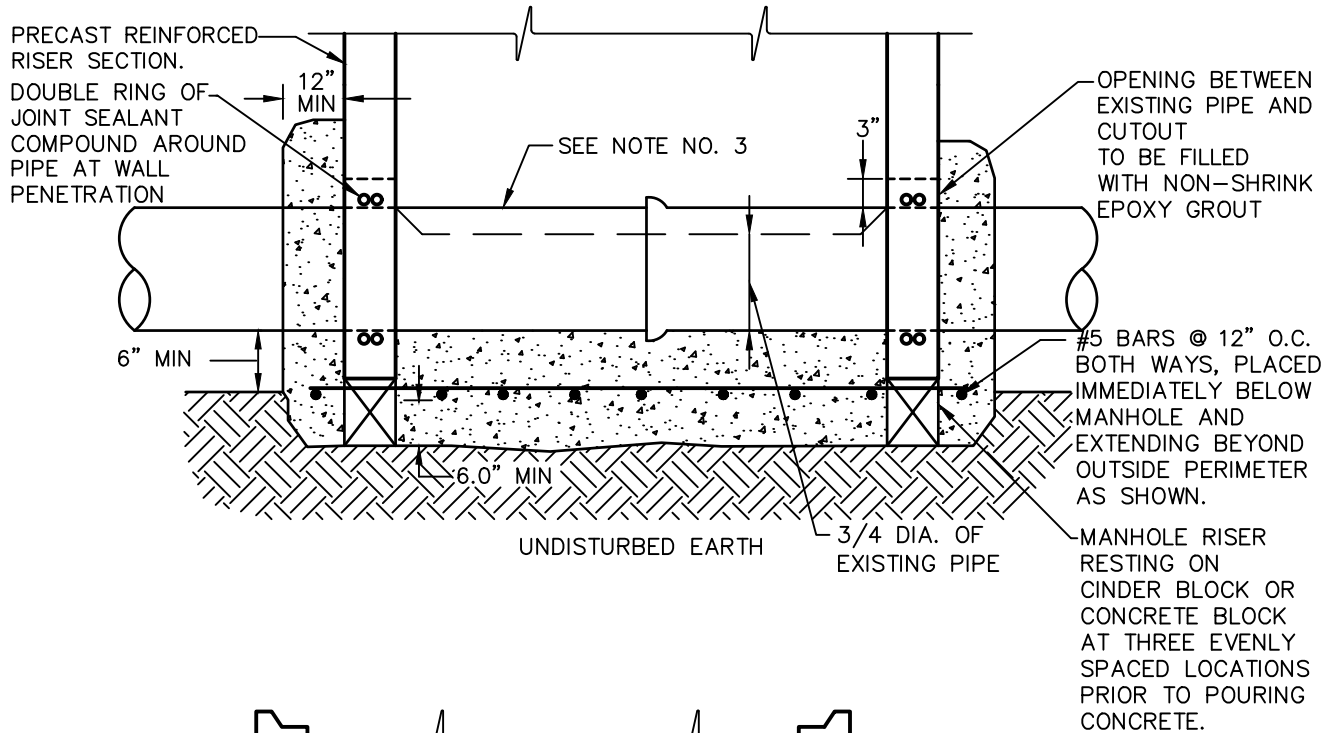

**NOTES:**

1. MANHOLE CONSTRUCTION SHALL BE THE SAME AS STANDARD MANHOLE EXCEPT AS NOTED.
2. EXISTING PIPE TO REMAIN UNTIL SATISFACTORY COMPLETION OF MANHOLE TESTING.
3. REMOVE CROWN OF EXISTING PIPE FLUSH WITH CONCRETE SHELF.

**DOGHOUSE MANHOLE CONSTRUCTION**

NTS

BUCKS COUNTY WATER & SEWER AUTHORITY			
DWG. BY: TSB	CKD. BY:	DOGHOUSE MANHOLE CONSTRUCTION	
DATE: 7-24-19	SCALE: None		
REVISION	DATE		
		STANDARD DETAIL	S-3

S:\mydocs\BCWSA Standard Detail Revisions\BCW-A\SPEC\SBCW-A.DWG Nov 25, 2019 2:52pm

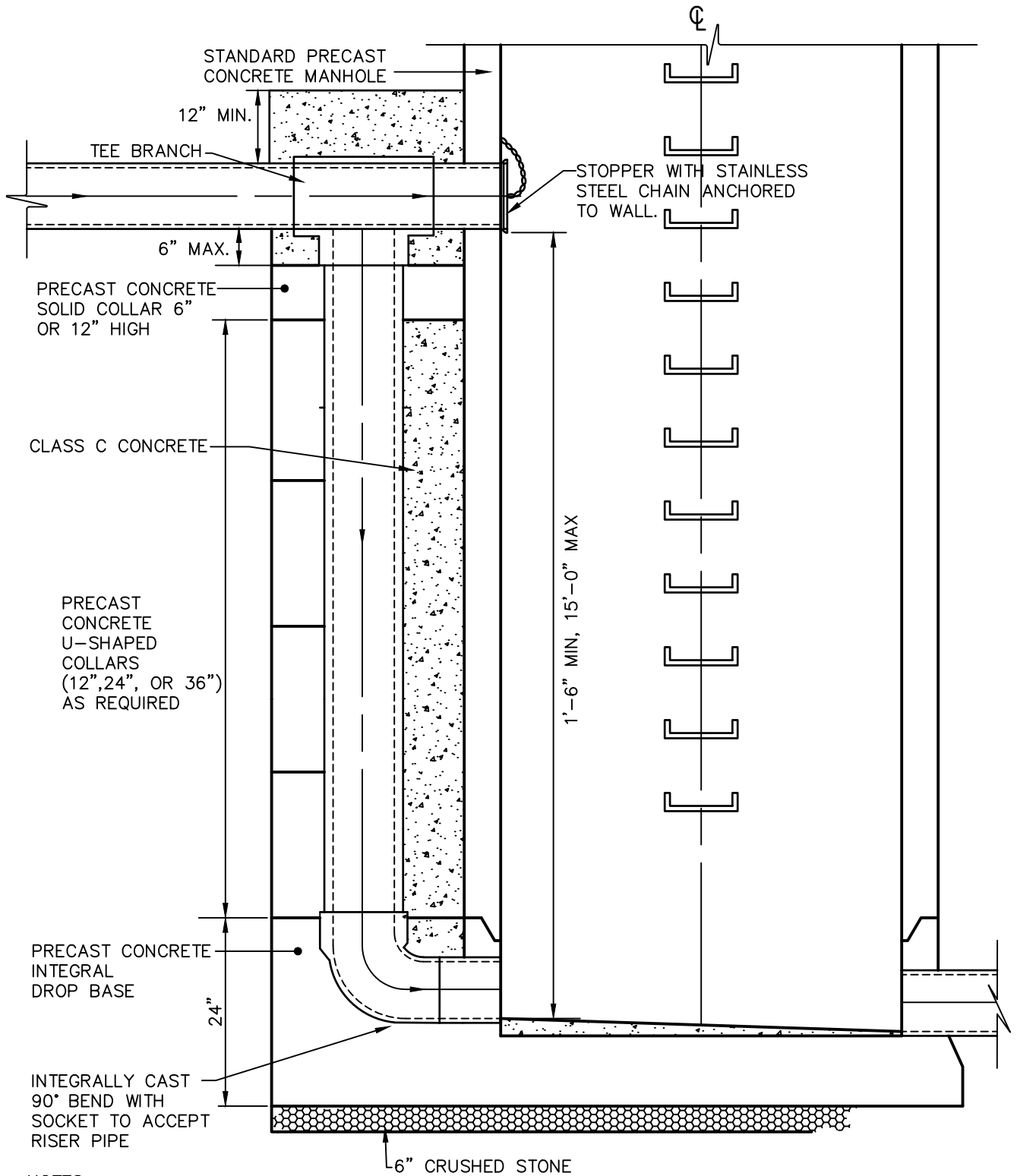

**NOTES:**

1. CONSTRUCTION TO BE SAME AS TYPE "A" STANDARD MANHOLE EXCEPT AS NOTED.

**DROP MANHOLE CONNECTION**

NTS

BUCKS COUNTY WATER & SEWER AUTHORITY			
DWG. BY: TSB	CKD. BY:	DROP MANHOLE CONNECTION	
DATE: 7-24-19	SCALE: None		
REVISION	DATE	STANDARD DETAIL S-4	

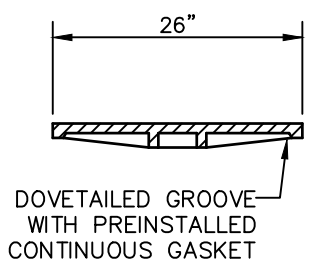
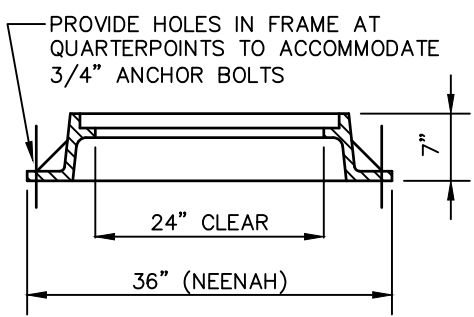
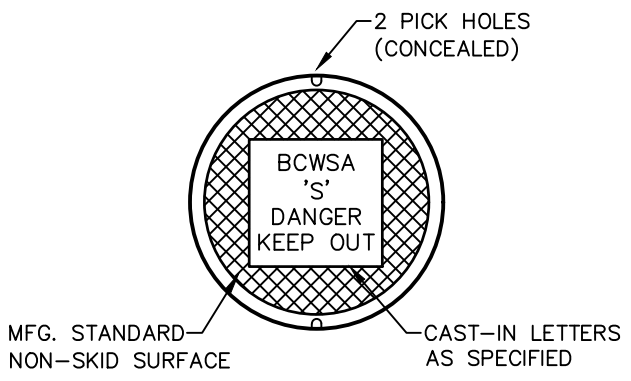
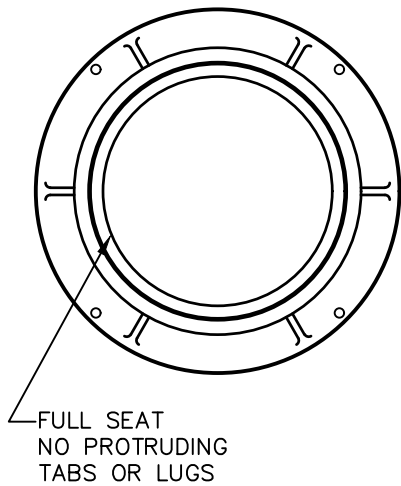

**FRAME**

**COVER**

**NOTES:**

1. MANHOLE FRAME AND COVER SHALL BE NEENAH FOUNDRY CO. MODEL R-1642, WITH SELF-SEALING LID GASKET (OR APPROVED EQUAL).
2. ALL MATERIALS TO BE GRAY CAST IRON ASTM A-48, CLASS 35.
3. FRAME AND COVER SHALL BE FOR HEAVY DUTY TRAFFIC, AASHTO HS-20.
4. PROVIDE FOUR (4) STAINLESS STEEL ANCHOR BOLTS, 3/4" DIA. MINIMUM.
5. COVER SHALL HAVE THE WORDS "BCWSA SANITARY SEWER" OR "BCWSA 'S' DANGER KEEP OUT" CAST THEREON IN 2" LETTERS.
6. FRAME AND COVER SHALL BE COATED WITH BLACK ASPHALTIC PAINT.
7. THE FOLLOWING MANUFACTURER'S STANDARD CASTING, OR APPROVED EQUAL, SHALL BE USED.

**STANDARD MANHOLE FRAME AND COVER**

NTS

BUCKS COUNTY WATER & SEWER AUTHORITY			
DWG. BY: TSB	CKD. BY:	STANDARD MANHOLE FRAME AND COVER	
DATE: 7-24-19	SCALE: None		
REVISION	DATE	STANDARD DETAIL S-5	

S:\mydocs\BCWSA Standard Detail Revisions\BCW-A\SPEC\SBCW-A.DWG Nov 25, 2019 2:52pm

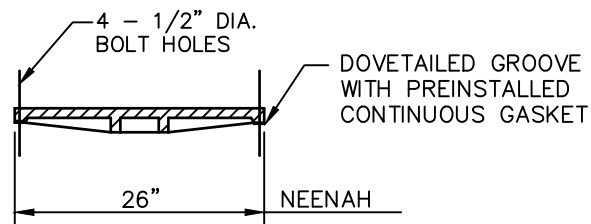
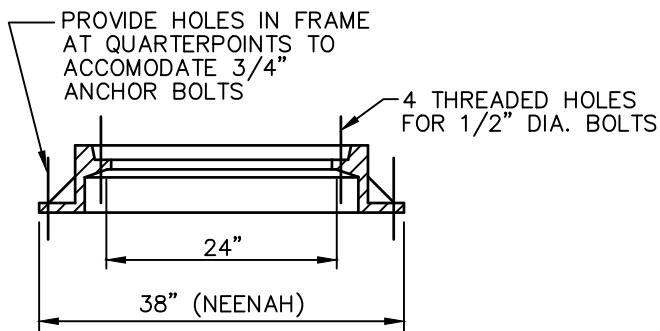
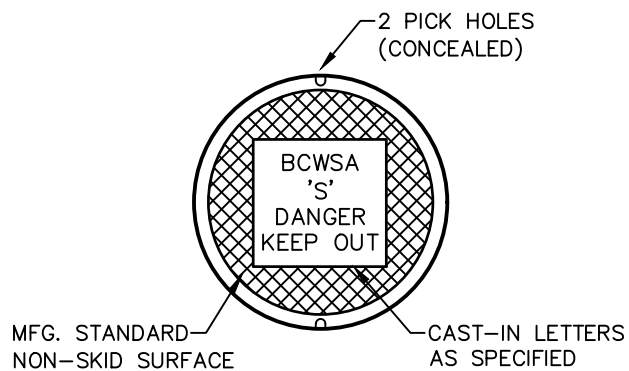
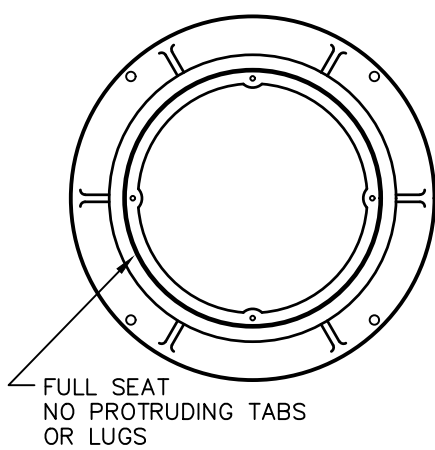

**FRAME**

**COVER**

**NOTES:**

1. MANHOLE FRAME AND COVER SHALL BE NEENAH FOUNDRY CO. MODEL R-1916-F (OR APPROVED EQUAL).
2. ALL MATERIALS TO BE GRAY CAST IRON ASTM A-48, CLASS 35.
3. FRAME AND COVER SHALL BE FOR HEAVY DUTY TRAFFIC, AASHTO HS-20.
4. BOLT COVER TO FRAME WITH FOUR (4) 1/2" COUNTERSUNK STAINLESS STEEL BOLTS WHICH MAKE A SEAL WITH A RUBBER "O" RING GASKET.
5. PROVIDE FOUR (4) STAINLESS STEEL ANCHOR BOLTS, 3/4" DIA. MINIMUM.
6. COVER SHALL HAVE THE WORDS "BCWSA SANITARY SEWER" OR "BCWSA 'S' DANGER KEEP OUT" CAST THEREON IN 2" LETTERS.
7. FRAME AND COVER SHALL BE COATED WITH BLACK ASPHALTIC PAINT.

**WATERTIGHT MANHOLE FRAME AND COVER**

NTS

BUCKS COUNTY WATER & SEWER AUTHORITY			
DWG. BY: TSB	CKD. BY:	WATERTIGHT MANHOLE FRAME AND COVER	
DATE: 7-24-19	SCALE: None		
REVISION	DATE		
		STANDARD DETAIL	S-6

S:\mydocs\BCWSA Standard Detail Revisions\BCW-A\SPEC\SBCW-A.DWG Nov 25, 2019 2:52pm

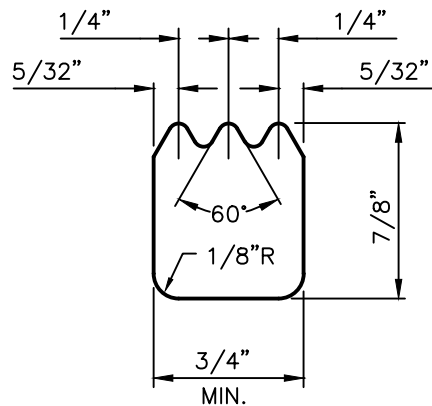
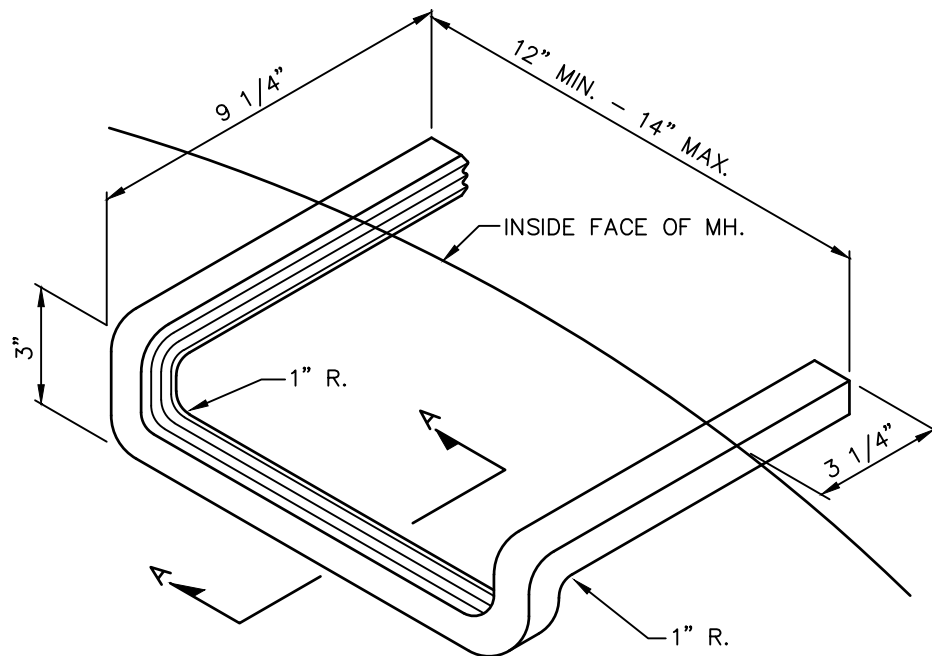

**SECTION A-A**

**NOTES:**

1. STEPS TO BE FABRICATED OF ALUMINUM ALLOY 6061-T6(EXTRUDED).
2. PORTIONS OF STEPS TO BE EMBEDDED IN WALLS OF MANHOLES OR CHAMBERS TO BE DIPPED IN HEAVY BODIED BITUMINOUS PAINT, OR PROVIDE PLASTIC INSERT.

**ALUMINUM MANHOLE STEP**

NTS

BUCKS COUNTY WATER & SEWER AUTHORITY			
DWG. BY: TSB	CKD. BY:	ALUMINUM MANHOLE STEP	
DATE: 7-24-19	SCALE: None		
REVISION	DATE	STANDARD DETAIL S-7	

S:\mydocs\BCWSA Standard Detail Revisions\BCW-A\SPEC\SBCW-A.DWG Nov 25, 2019 2:52pm

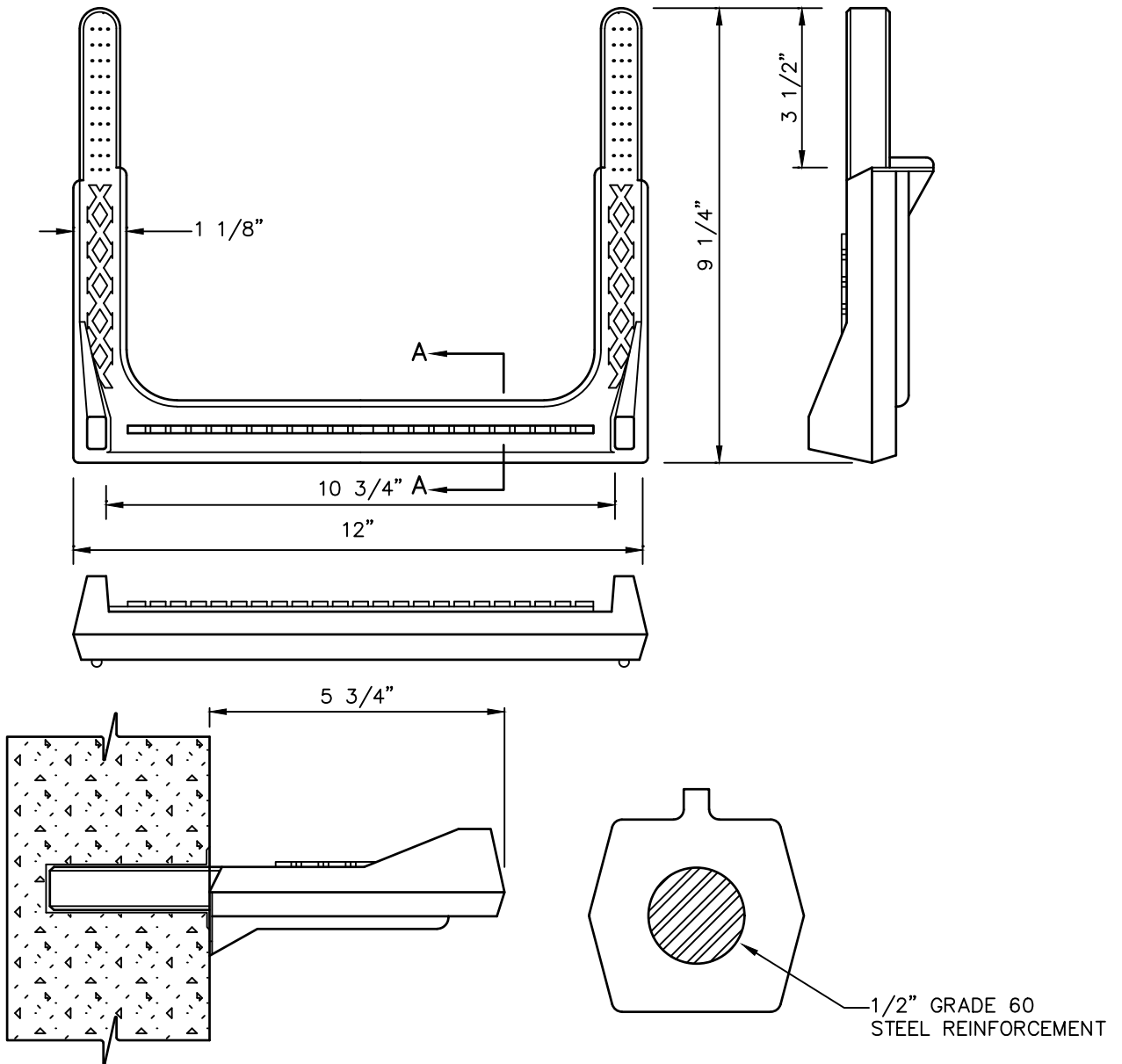

**NOTE:**

STEPS TO BE FABRICATED FROM  
COPOLYMER POLYPROPYLENE PLASTIC.

**POLYPROPYLENE MANHOLE STEP**

NTS

BUCKS COUNTY WATER & SEWER AUTHORITY			
DWG. BY: TSB	CKD. BY:	POLYPROPYLENE MANHOLE STEP	
DATE: 7-24-19	SCALE: None		
REVISION	DATE	STANDARD DETAIL S-8	

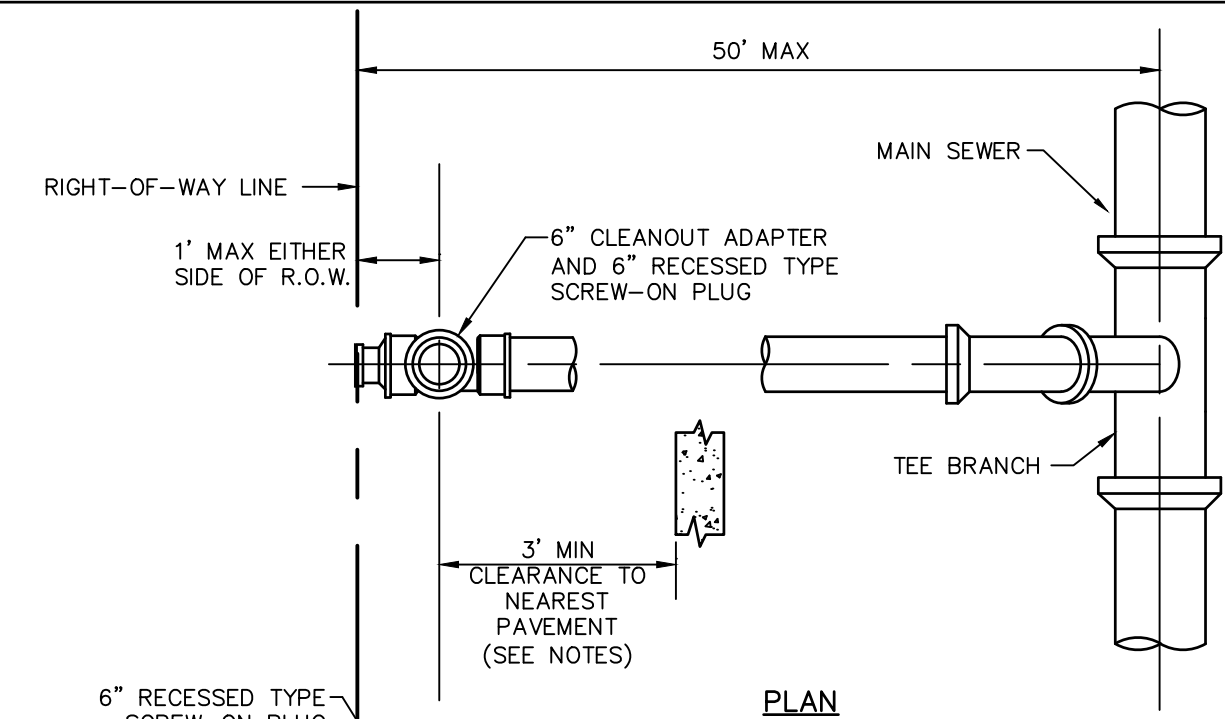

**PLAN**

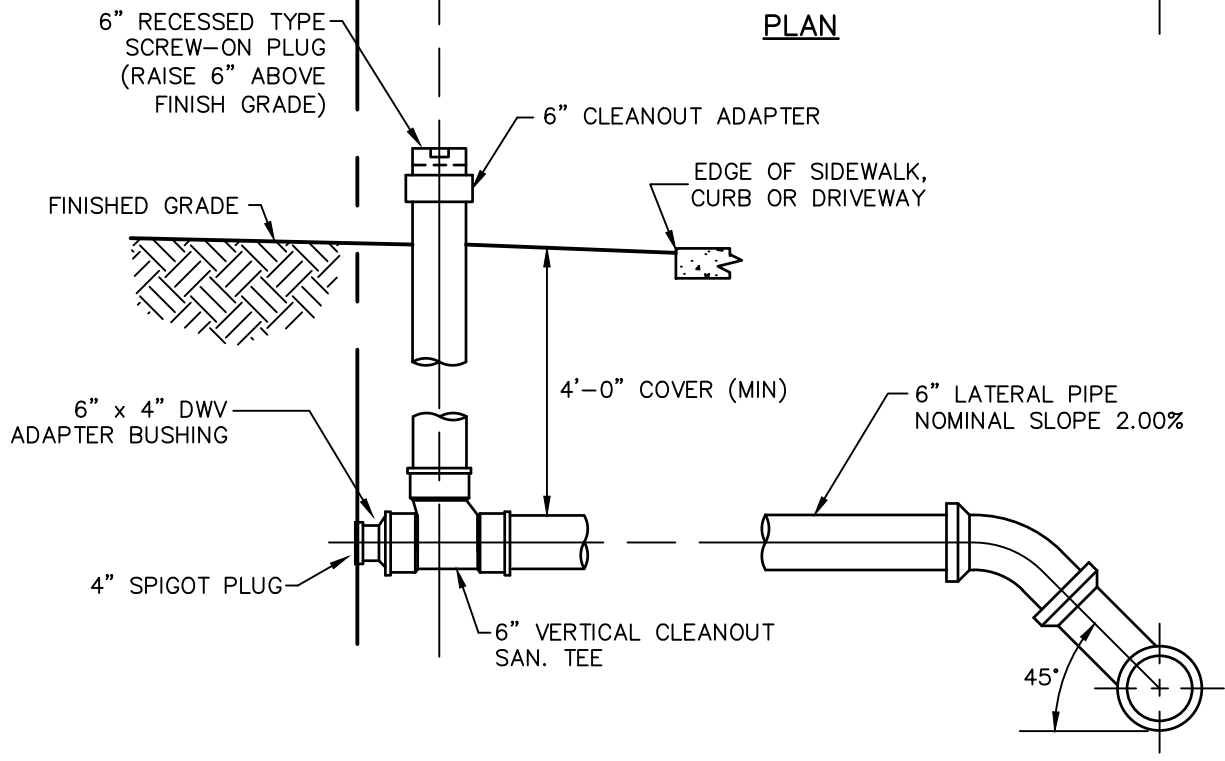

**ELEVATION**

**NOTE**

CLEANOUTS SHOULD NOT TYPICALLY BE INSTALLED IN OR NEAR PAVED AREAS. UNDER SPECIAL CONDITIONS, A CLEANOUT LOCATED IN, OR LESS THAN 3 FEET FROM, A PAVED AREA MAY BE INSTALLED IF A PROTECTION SLEEVE AS SHOWN IN DETAIL S-12 IS PROVIDED.

**LATERAL CONNECTION SHALLOW SEWER**

NTS

BUCKS COUNTY WATER & SEWER AUTHORITY			
DWG. BY: TSB	CKD. BY:	LATERAL CONNECTION SHALLOW SEWER	
DATE: 7-24-19	SCALE: None		
REVISION	DATE		
		STANDARD DETAIL	S-9

S:\mydocs\BCWSA Standard Detail Revisions\BCW-A\SPEC\SBCW-A.DWG Nov 25, 2019 2:52pm

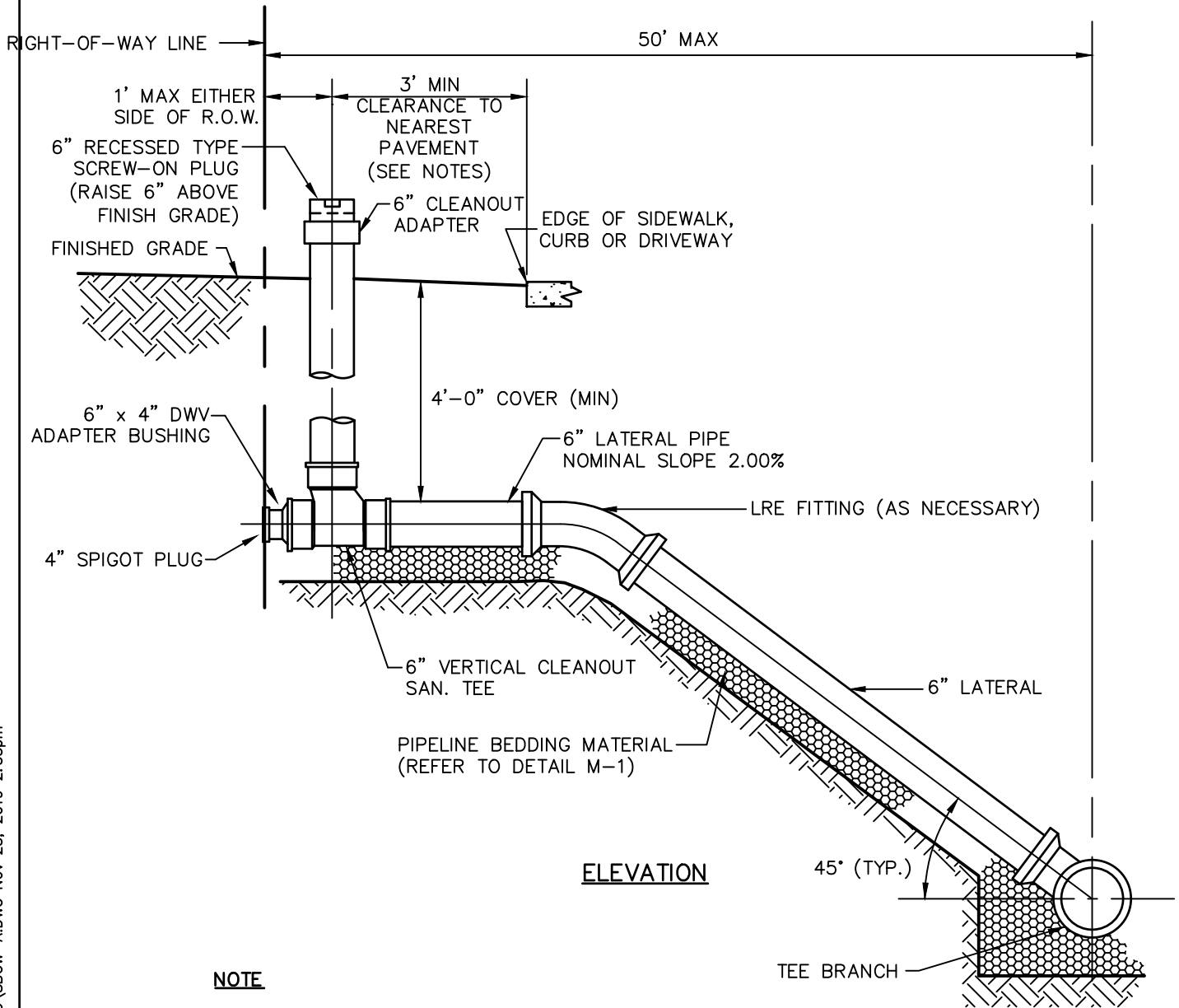

**NOTE**

- CLEANOUTS SHOULD NOT TYPICALLY BE INSTALLED IN OR NEAR PAVED AREAS. UNDER SPECIAL CONDITIONS, A CLEANOUT LOCATED IN, OR LESS THAN 3 FEET FROM, A PAVED AREA MAY BE INSTALLED IF A PROTECTION SLEEVE AS SHOWN IN DETAIL S-12 IS PROVIDED.
- THIS DETAIL APPLIES WHEN THE SEWER MAIN IS 10' DEEP OR GREATER.

**LATERAL CONNECTION DEEP SEWER**

NTS

BUCKS COUNTY WATER & SEWER AUTHORITY			
DWG. BY: TSB	CKD. BY:	LATERAL CONNECTION DEEP SEWER	
DATE: 7-24-19	SCALE: None		
REVISION	DATE	STANDARD DETAIL S-10	

S:\BCWSA Standard Detail Revisions - 2022\BCW-A\SPEC\SBCW-A.DWG Apr 06, 2022 3:10pm

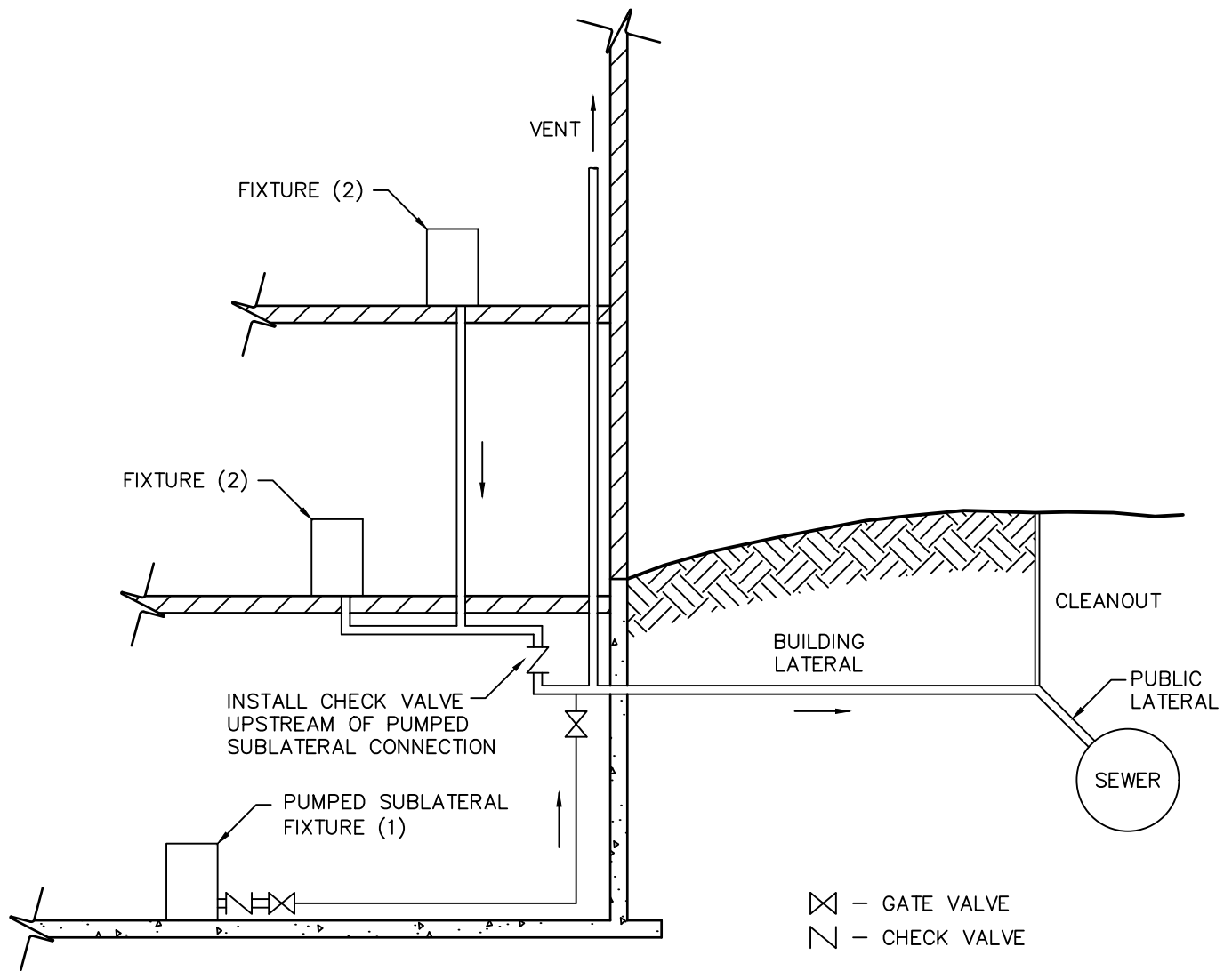

**NOTES:**

1. PUMPED SUBLATERAL FIXTURE (WASHING MACHINE, TOILET OR ENCLOSED GRINDER PUMP UNIT).
2. ABOVE-LATERAL FIXTURES DISCHARGING TO A POINT ABOVE THE LATERAL.
3. ALL INSTALLATION WORK SHALL CONFORM TO PA UCC, LATEST REVISIONS.

GENERAL ELEVATION FOR CONNECTION OF PUMPED SUBLATERAL FIXTURES  
(DISCHARGED BELOW THE SEWER LATERAL)

**SERVICE CONNECTION FOR SUBLATERAL FACILITIES**

NTS

BUCKS COUNTY WATER & SEWER AUTHORITY			
DWG. BY: TSB	CKD. BY:	SERVICE CONNECTION FOR SUBLATERAL FACILITIES	
DATE: 7-24-19	SCALE: None		
REVISION	DATE		
KTI	4/6/22	STANDARD DETAIL	S-11

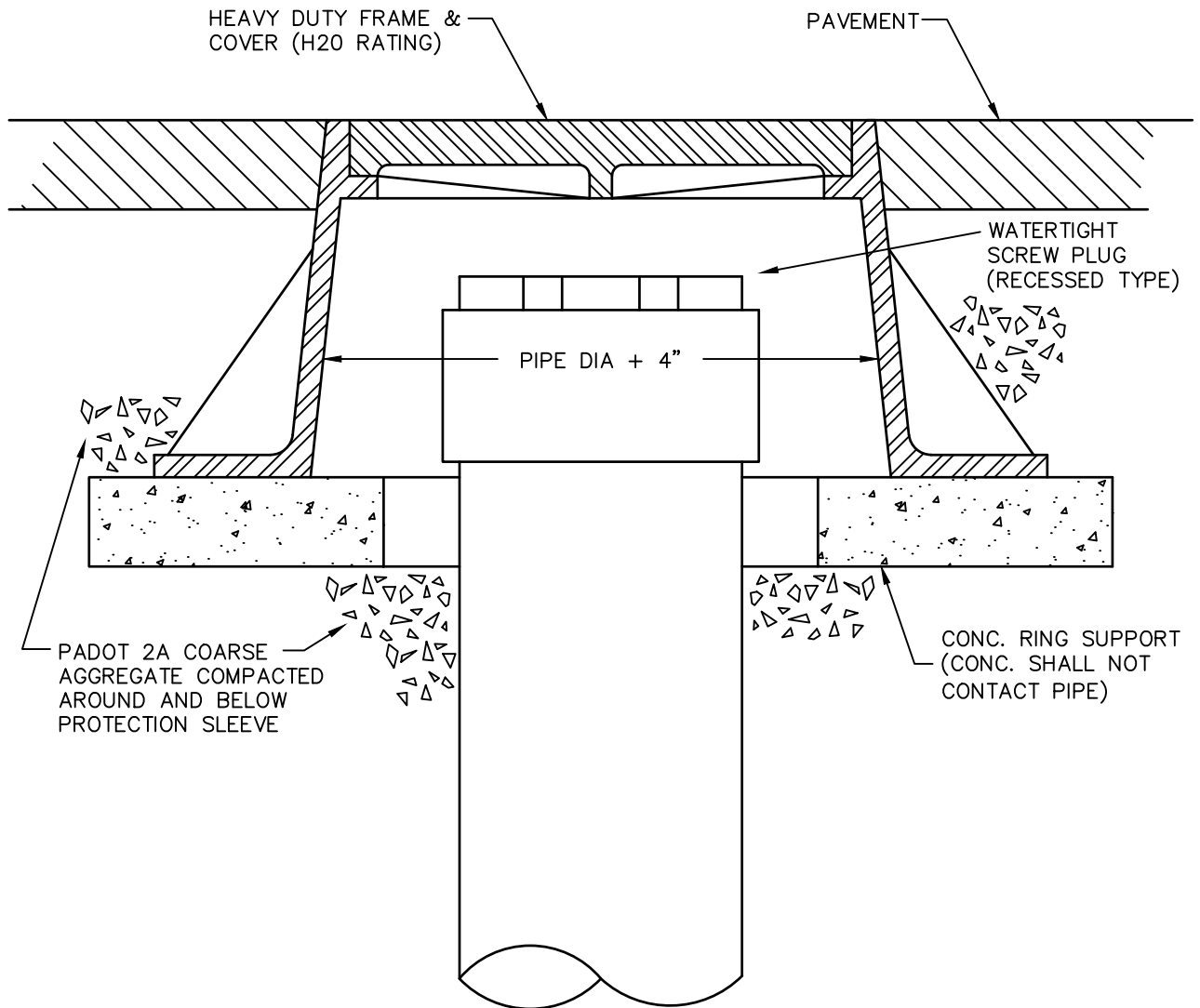

**NOTES:**

1. FRAME AND COVER SHALL BE NEENAH FOUNDRY COMPANY MODEL R-1976 OR APPROVED EQUAL
2. CLEANOUT PROTECTION SLEEVES ARE TO BE INSTALLED FOR CLEANOUTS LOCATED IN PAVED AREAS, OR LESS THAN 3 FEET FROM A PAVED AREA.

**CLEANOUT PROTECTION SLEEVE**

NTS

BUCKS COUNTY WATER & SEWER AUTHORITY			
DWG. BY: TSB	CKD. BY:	CLEANOUT PROTECTION SLEEVE (FOR USE IN OR NEAR PAVED AREAS)	
DATE: 7-24-19	SCALE: None		
REVISION		DATE	
KTI		4/6/22	
		STANDARD DETAIL S-12	

S:\mydocs\BCWSA Standard Detail Revisions\BCW-A\SPEC\SBCW-A.DWG Nov 25, 2019 2:53pm

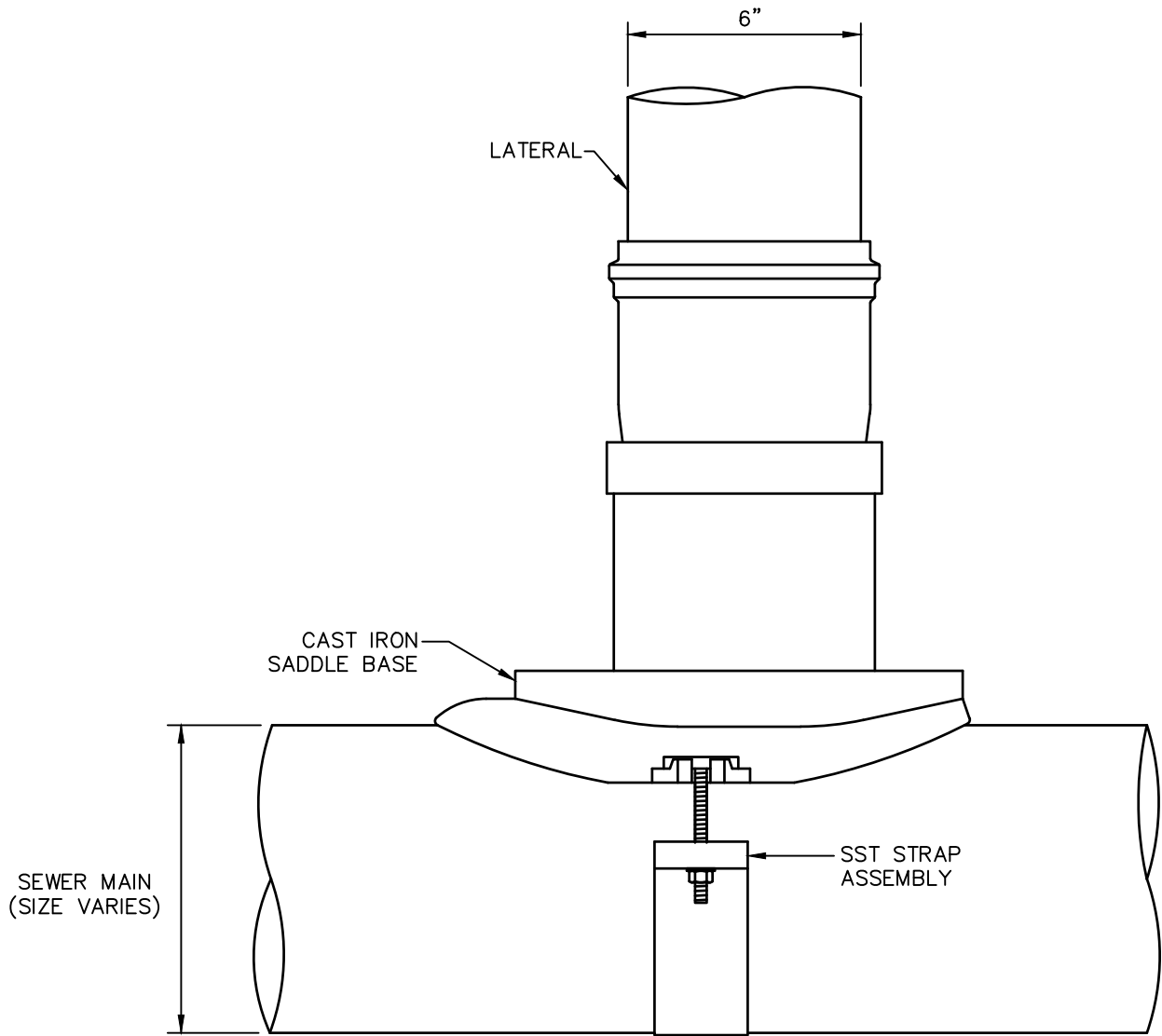

**NOTES:**

1. SEWER PIPE SADDLE, MANUFACTURED BY ROMAC INDUSTRIES, INC (MODEL CB) OR APPROVED EQUAL.
2. PLACE SADDLE SO THAT LATERAL CONNECTS TO TOP OF MAIN AT A 45° VERTICAL ANGLE.

**SEWER SADDLE**

NTS

BUCKS COUNTY WATER & SEWER AUTHORITY			
DWG. BY: TSB	CKD. BY:	SEWER SADDLE	
DATE: 7-24-19	SCALE: None		
REVISION	DATE	STANDARD DETAIL S-13	

S:\mydocs\BCWSA Standard Detail Revisions\BCW-A\SPEC\BCW-A.DWG Nov 25, 2019 2:53pm

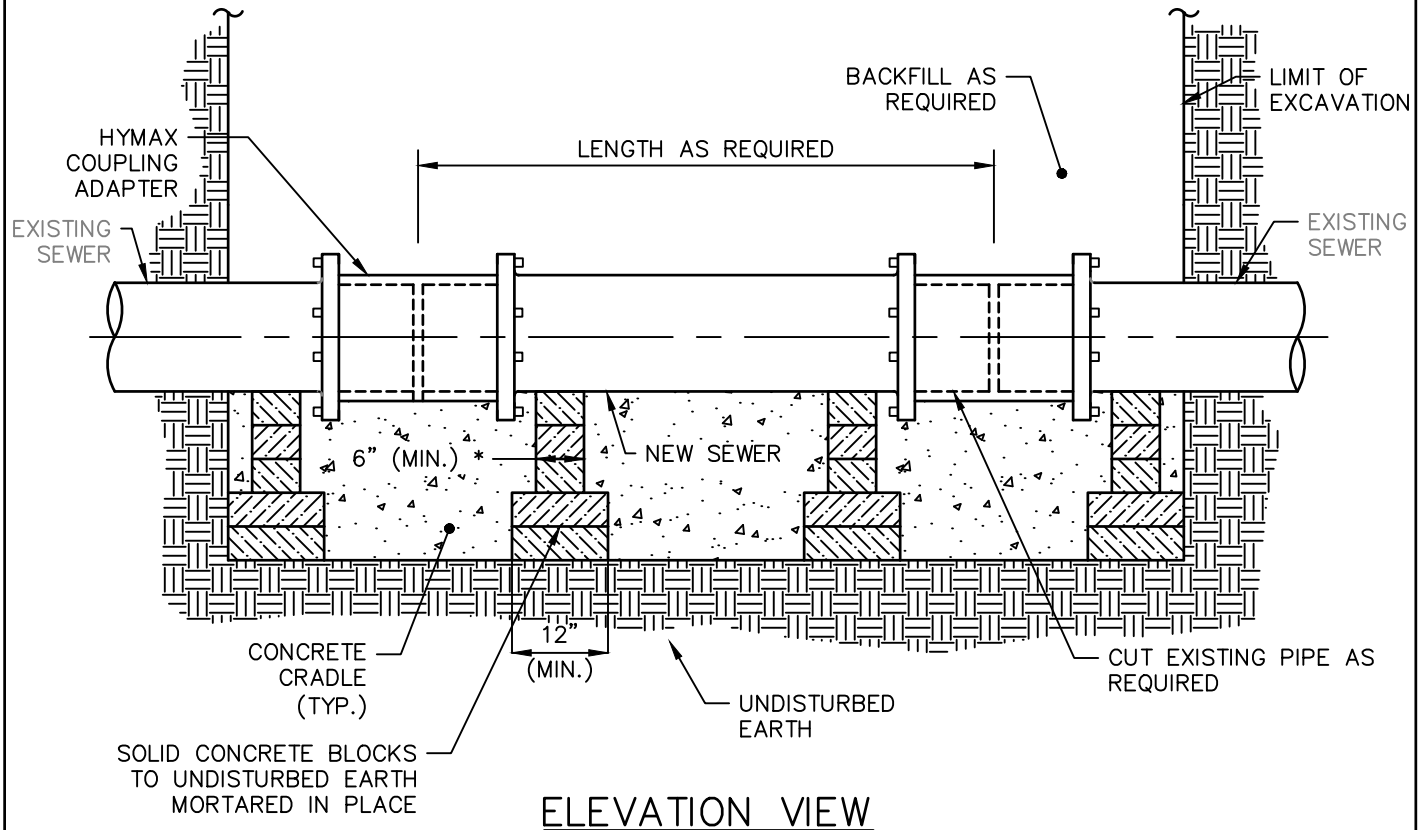

**REPLACEMENT OF EXISTING SEWER**

NTS

BUCKS COUNTY WATER & SEWER AUTHORITY			
DWG. BY: TSB	CKD. BY:	REPLACEMENT OF EXISTING SEWER	
DATE: 7-24-19	SCALE: None		
REVISION	DATE	STANDARD DETAIL S-14	



S:\BCWSA Standard Detail Revisions - 2022\BCW-A\SPEC\BCW-A.DWG Apr 06, 2022 10:59am

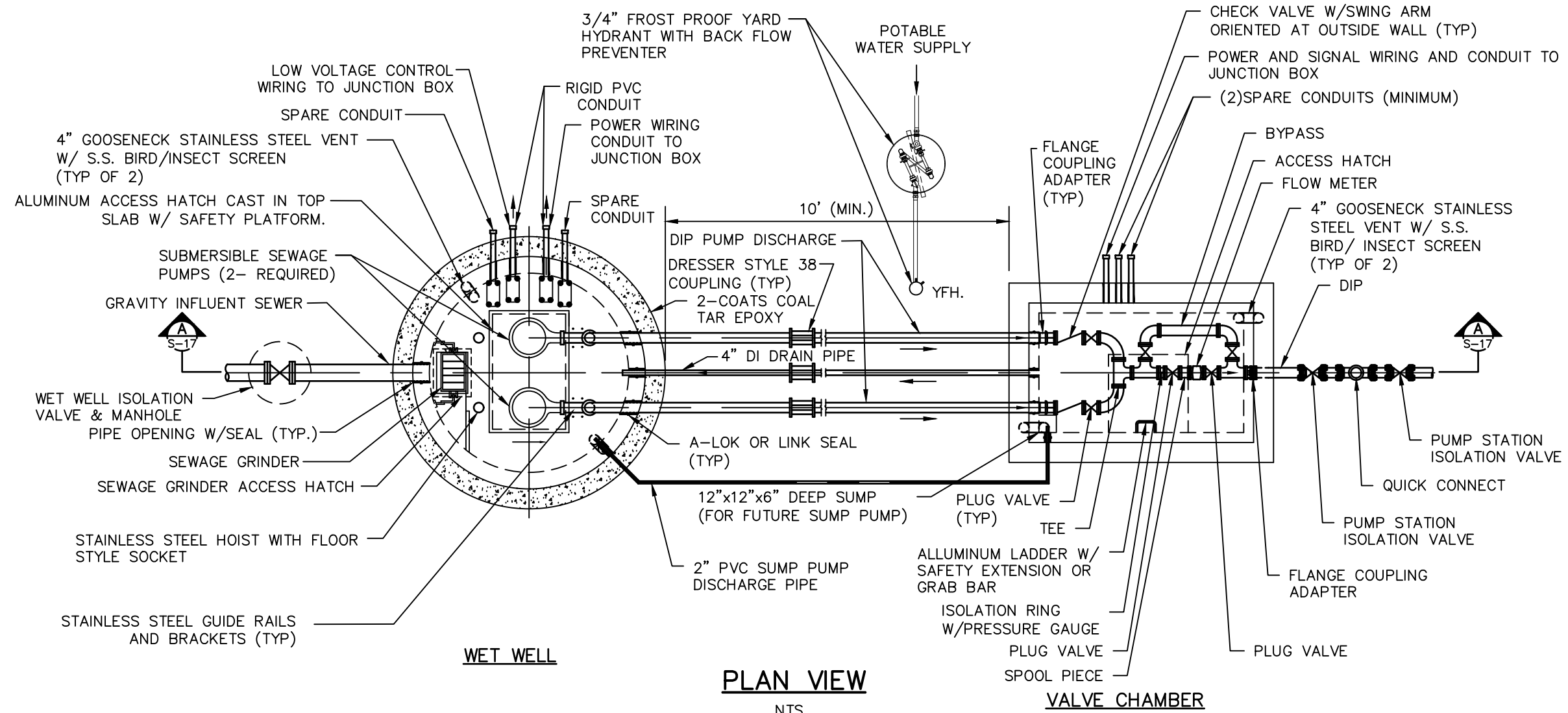

**PUMP STATION NOTES:**

- PUMP STATION WET WELL AND VALVE CHAMBER EXTERIOR SHALL RECEIVE (2) COATS OF COAL TAR EPOXY IN ACCORDANCE WITH THE STANDARD SPECIFICATIONS.
- PUMP STATION WET WELL AND VALVE CHAMBER INTERIOR SHALL RECEIVE COATING PER SPECIFICATIONS.
- ALL PUMP STATION AND VALVE CHAMBER HARDWARE SHALL BE STAINLESS STEEL.
- THE PUMP STATION FORCE MAIN SHALL HAVE A MINIMUM OF 4 FEET COVER AT ALL TIMES.
- ALL PUMP STATION INTERNAL PIPING SHALL BE FLANGED CLASS 53 DIP WITH DOUBLE LINING OR APPROVED EQUAL.
- USE STAINLESS STEEL CHAIN FOR PUMP REMOVAL AND GRINDER REMOVAL.
- WET WELL TO BE CONSTRUCTED IN ACCORDANCE WITH ASTM C478.
- VALVE VAULT TO BE CONSTRUCTED IN ACCORDANCE WITH ASTM C913.
- PROVIDE DIMENSIONS FOR ALL ACCESS HATCHES, PUMPS, SEWAGE GRINDER, AND TRASH BASKET. LOCATE CENTER LINE OF ACCESS HATCHES, SEWAGE GRINDER AND PUMPS RELATIVE TO THE CENTERLINE OF THE WET WELL/ VALVE CHAMBER. LOCATE HOIST RELATIVE TO CENTER OF PUMPS AND VERIFY ADEQUATE HOIST CAPACITY BY PROVIDING SEWAGE GRINDER AND PUMP WEIGHT.
- PUMP STATION TO BE EQUIPPED WITH A GENERATOR/CONTROLS BUILDING TO HOUSE EMERGENCY GENERATOR AND ALL PUMP STATION CONTROLS.
- THE BYPASS SHALL BE MANUALLY OPERATED TO ALLOW THE STATION TO REMAIN IN OPERATION SHOULD THE FLOW METER BE REMOVED FOR MAINTENANCE. DEPENDING ON THE SIZE OF THE VAULT, THE PIPING AND THE SITE CONFIGURATION, IT MAY BE NECESSARY FOR A PORTION OF THE BYPASS TO BE LOCATED EXTERIOR OF THE VAULT. THIS SHALL BE SUBJECT TO REVIEW AND APPROVAL OF THE AUTHORITY.
- DESIGNER SHALL ENSURE THAT AN ADEQUATE LENGTH OF STRAIGHT PIPE IS PROVIDED BOTH UPSTREAM AND DOWNSTREAM OF THE METER, IN ACCORDANCE WITH THE FLOW METER MANUFACTURER'S RECOMMENDATIONS. FLOW METERS TO BE MANUFACTURED BY ABB OR TOSHIBA.

BUCKS COUNTY WATER & SEWER AUTHORITY			
DWG. BY: TSB	CKD. BY:	TYPICAL PUMP STATION PLAN VIEW AND NOTES	
DATE: 7-24-19	SCALE: None		
REVISION	DATE		
KTI	4/6/22	STANDARD DETAIL	S-16

C:\Users\kicstello\CORP\OneDrive - Carroll Engineering\BCWSA Standard Detail Revisions - 2022\BCW-A\SPEC\SBCW-A.DWG May 25, 2022 11:32am

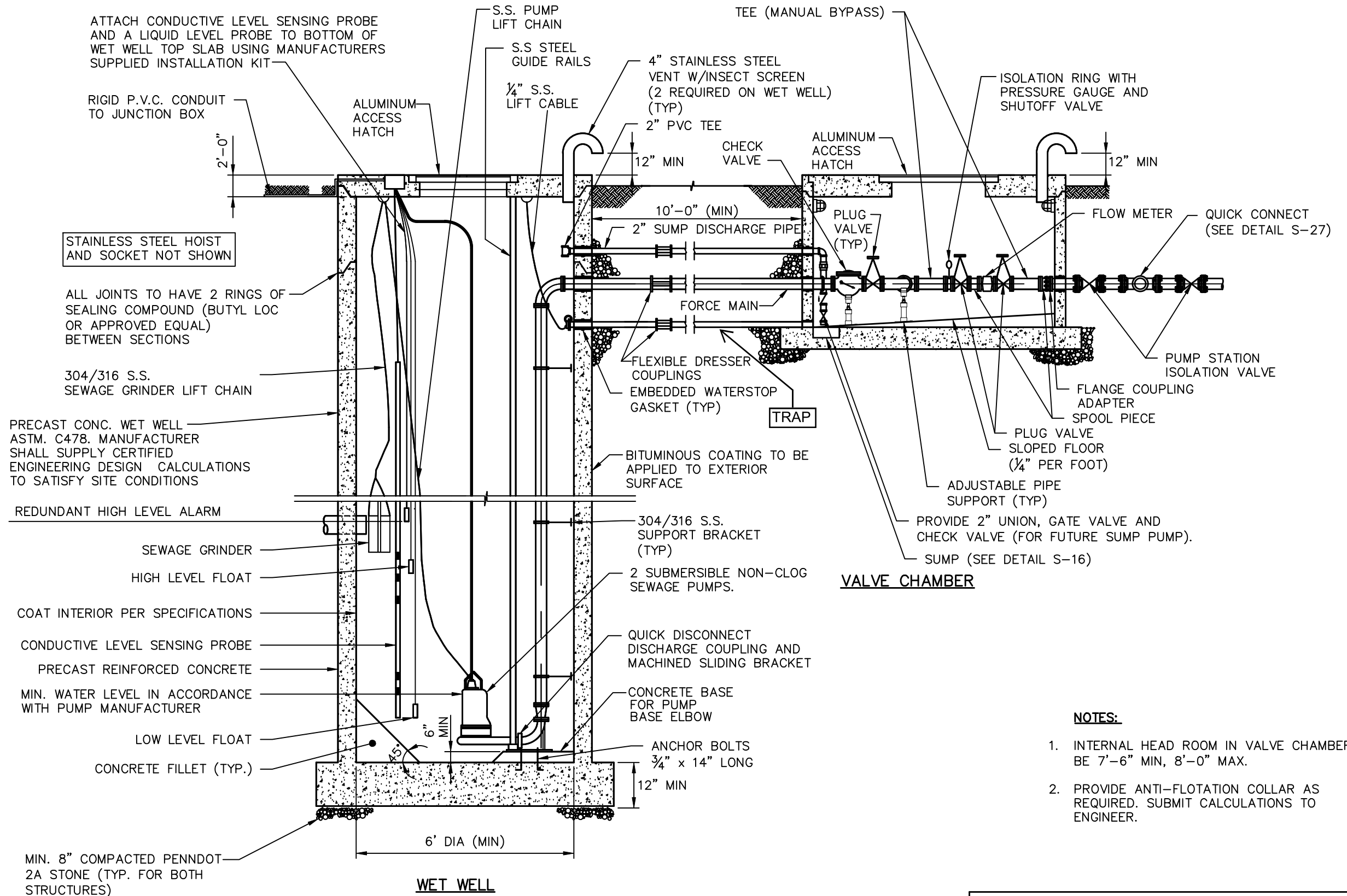

- NOTES:**
- INTERNAL HEAD ROOM IN VALVE CHAMBER TO BE 7'-6" MIN, 8'-0" MAX.
  - PROVIDE ANTI-FLOTATION COLLAR AS REQUIRED. SUBMIT CALCULATIONS TO ENGINEER.

**SECTION A-A**  
**SECTION VIEW**  
NTS

BUCKS COUNTY WATER & SEWER AUTHORITY			
DWG. BY: TSB	CKD. BY:	TYPICAL PUMP STATION SECTION VIEW	
DATE: 7-24-19	SCALE: None		
REVISION	DATE		
KTI	4/6/22		
STANDARD DETAIL		S-17	

**NOTES:**

1. THIS DRAWING IS FOR CONCEPTUAL PURPOSES ONLY. FABRICATION OF THIS SYSTEM SHALL BE IN ACCORDANCE WITH THE MANUFACTURER'S RECOMMENDATIONS AND SHALL BE SUBJECT TO APPROVAL BY THE ENGINEER PRIOR TO CONSTRUCTION.
2. VERIFY MANUFACTURER'S DIMENSIONS.
3. ALL SUPPORTS, FRAMES, ANCHORS, AND HARDWARE TO BE STAINLESS STEEL.

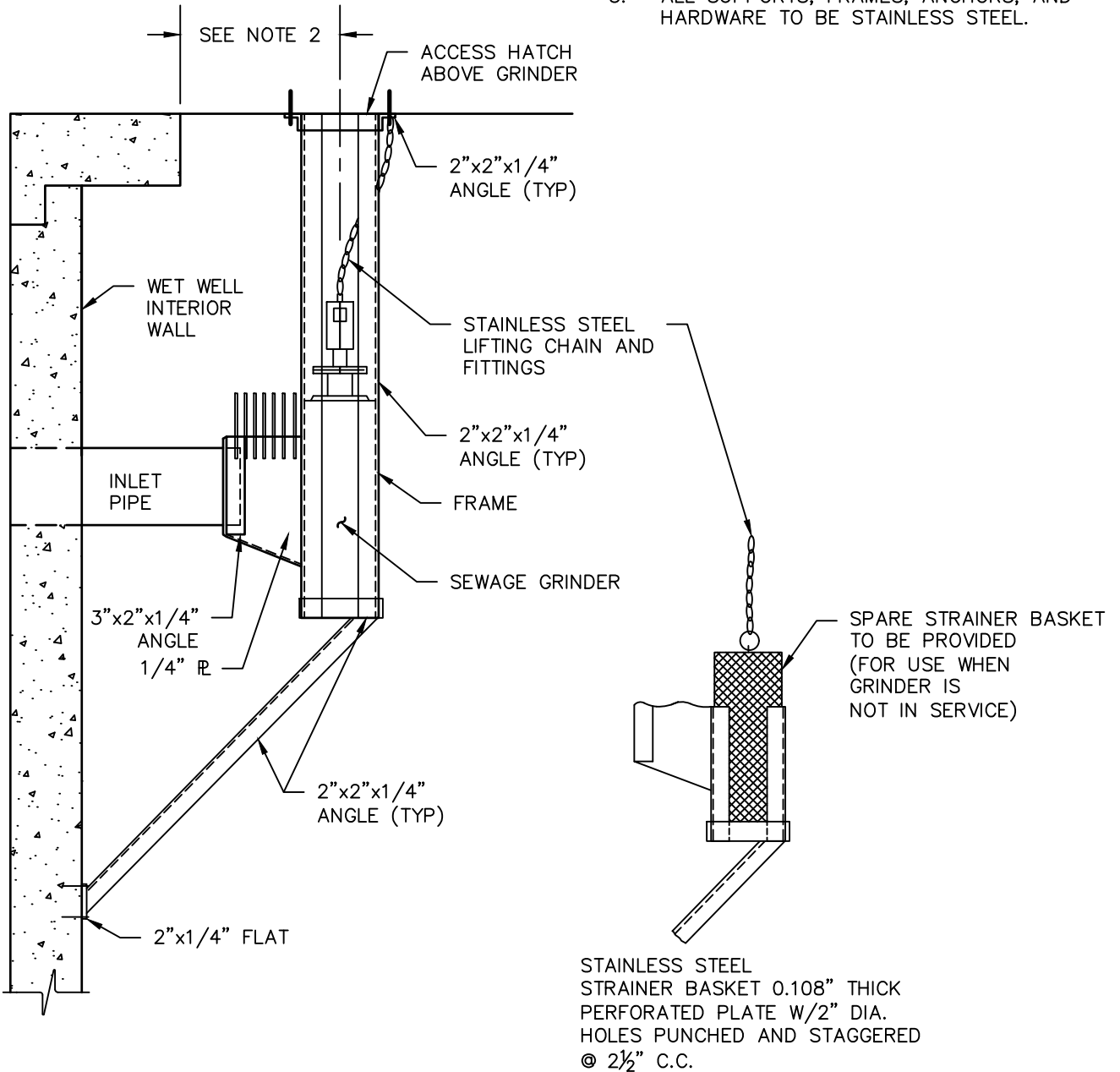

**TYPICAL SEWAGE GRINDER CHANNEL  
FRAME AND RAIL SYSTEM**

NTS

**BUCKS COUNTY WATER & SEWER AUTHORITY**

DWG. BY: TSB	CKD. BY:	TYPICAL SEWAGE GRINDER CHANNEL FRAME AND RAIL SYSTEM
DATE: 7-24-19	SCALE: None	
REVISION	DATE	STANDARD DETAIL S-18

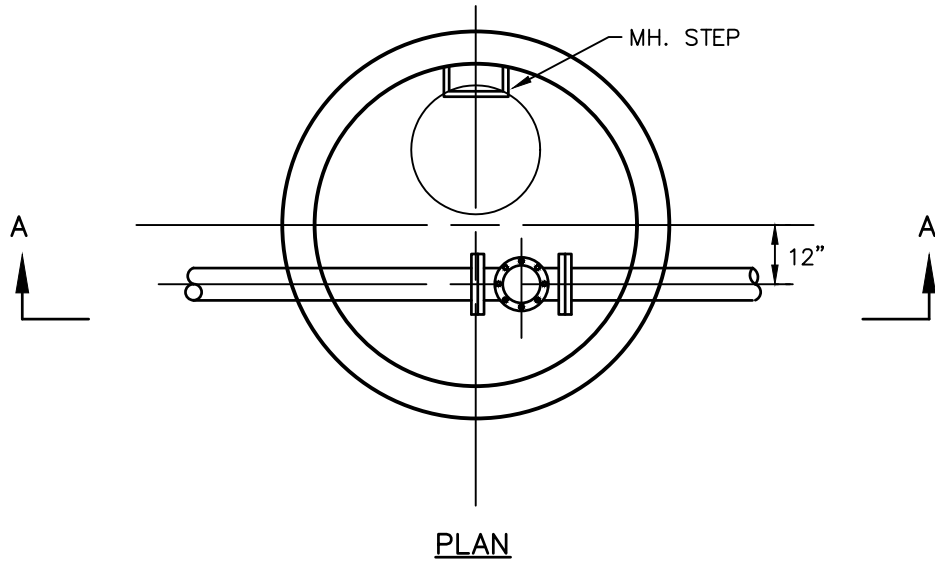

GROUND ELEVATION ————— WATERTIGHT MH. FRAME AND COVER

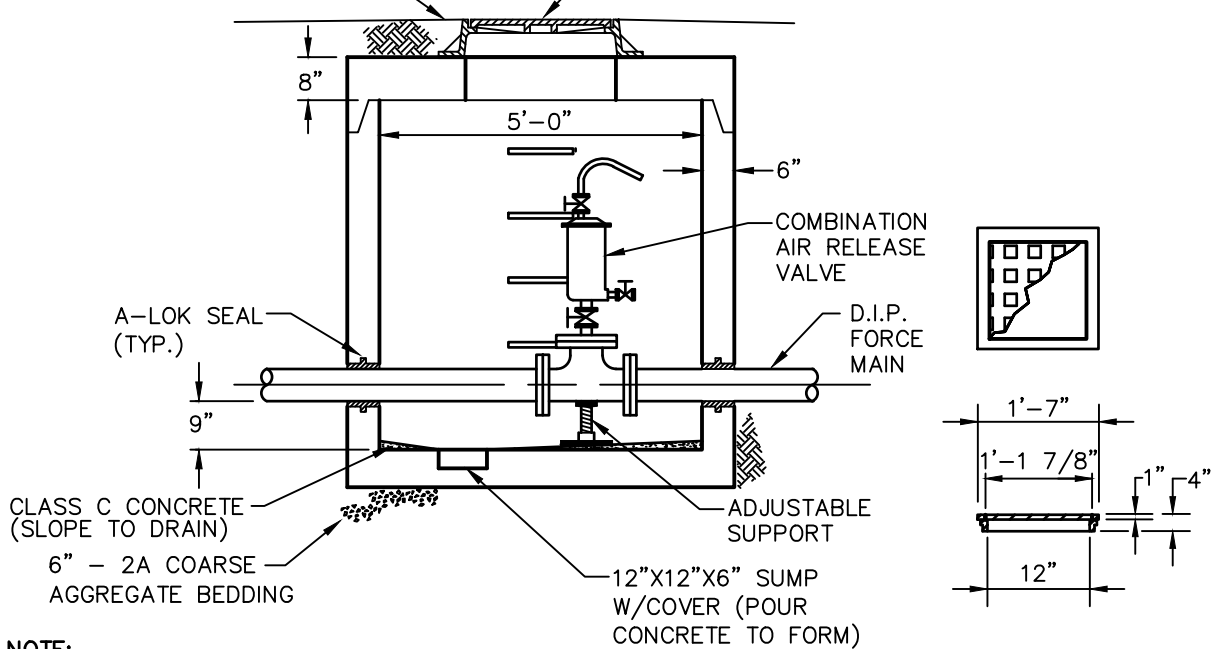

**SUMP FRAME & GRATE**

**NOTE:**

AIR RELEASE CHAMBER SHALL BE CONSTRUCTED IN ACCORDANCE WITH DETAILS S-1 AND S-2.

**SECTION A-A**

**FORCE MAIN AIR RELEASE CHAMBER**

NTS

S:\mydocs\BCWSA Standard Detail Revisions\BCW-A\SPEC\SBCW-A.DWG Nov 25, 2019 2:53pm

**BUCKS COUNTY WATER & SEWER AUTHORITY**

DWG. BY: TSB	CKD. BY:	FORCE MAIN AIR RELEASE CHAMBER
DATE: 7-24-19	SCALE: None	
REVISION	DATE	STANDARD DETAIL S-19

S:\mydocs\BCWSA Standard Detail Revisions\BCW-A\SPEC\SBCW-A.DWG Nov 25, 2019 2:53pm

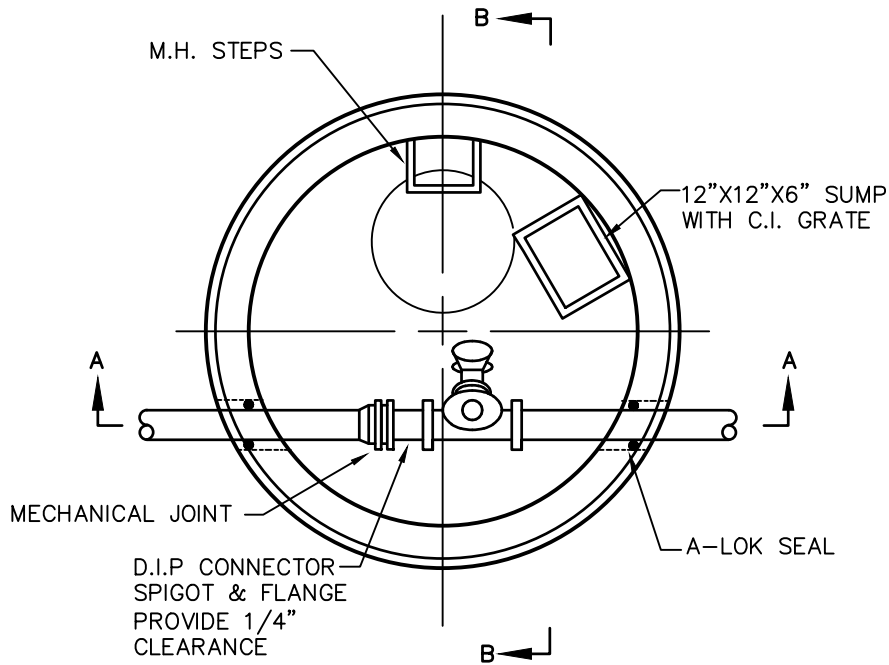

**PLAN SECTION**

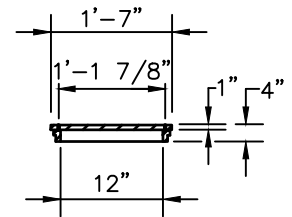
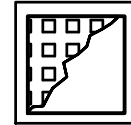

**SUMP FRAME & GRATE**

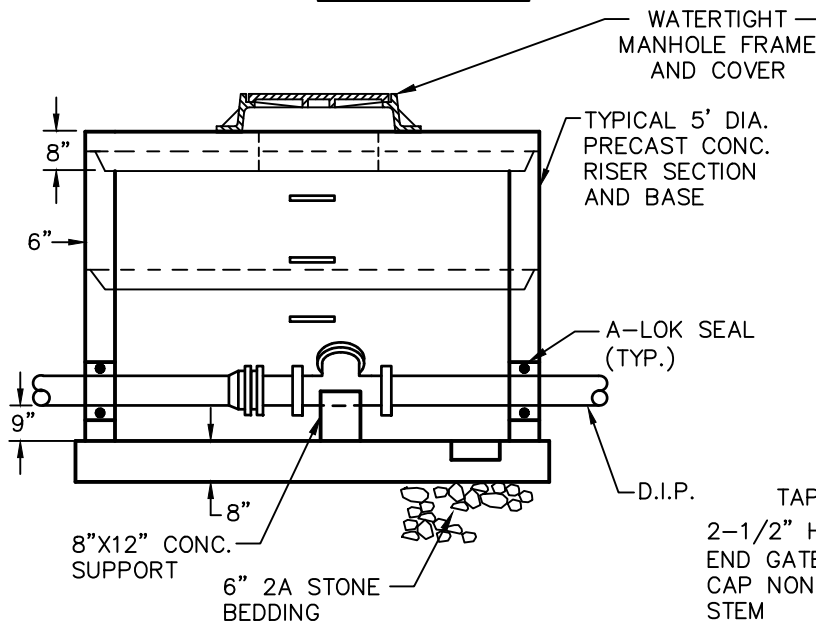

**SECTION A-A**

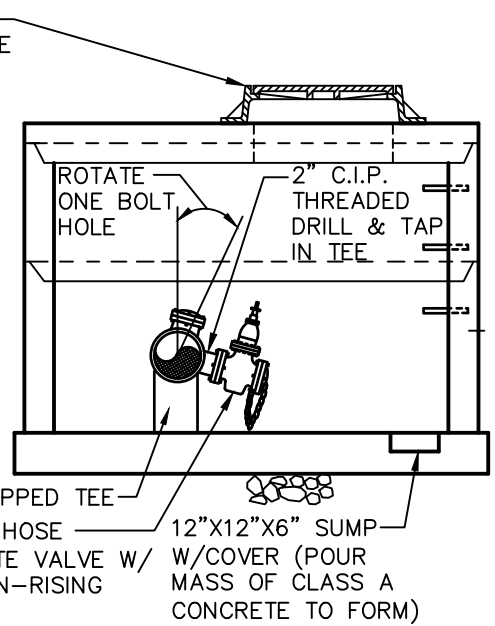

**SECTION B-B**

**NOTE:**

CHAMBER TO BE CONSTRUCTED IN ACCORDANCE WITH REQUIREMENTS NOTED ON STANDARD DETAIL S-19-FORCE MAIN AIR RELEASE CHAMBER.

**FORCE MAIN CLEANOUT CHAMBER**

NTS

BUCKS COUNTY WATER & SEWER AUTHORITY			
DWG. BY: TSB	CKD. BY:	FORCE MAIN CLEANOUT CHAMBER	
DATE: 7-24-19	SCALE: None		
REVISION	DATE	STANDARD DETAIL S-20	

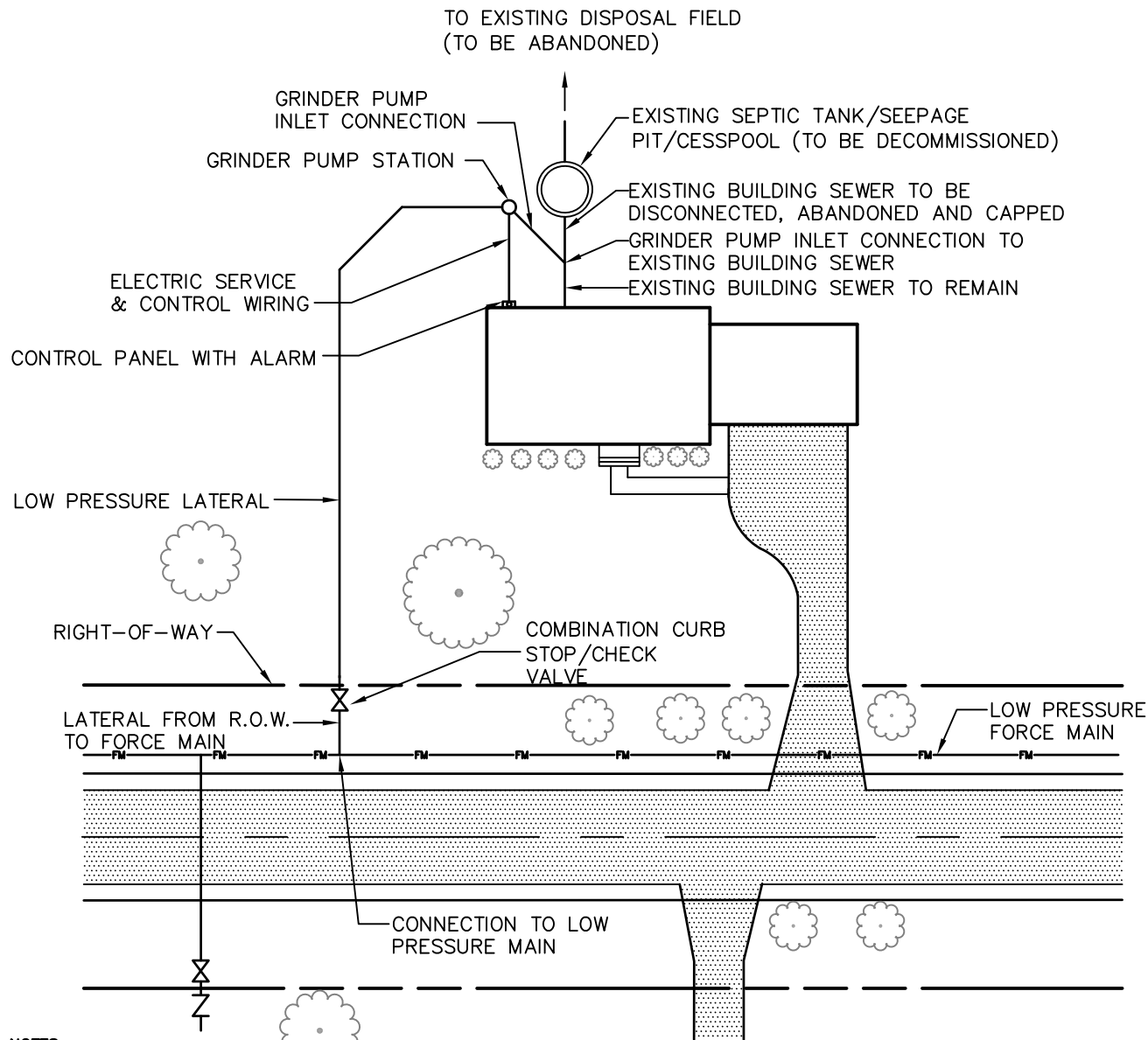

**NOTES:**

1. INSTALLATION OF ALL EQUIPMENT, INCLUDING GRINDER PUMP BASIN AND CONTROL/ALARM PANEL, SHALL BE IN STRICT ADHERENCE TO MANUFACTURER'S REQUIREMENTS.
2. DESIGN, LAYOUT, CONSTRUCTION, OWNERSHIP AND MAINTENANCE OF ALL EQUIPMENT TO BE INSTALLED, INCLUDING GRINDER PUMP BASIN, CONTROL/ALARM PANEL AND LOW PRESSURE LATERAL, SHALL REMAIN PRIVATE AND BE THE SOLE RESPONSIBILITY OF THE HOMEOWNER.
3. FINISH GRADING MUST SLOPE AWAY FROM GRINDER PUMP BASIN
4. CONTRACTOR SHALL ENSURE THAT CURB STOP AS WELL AS SHUT-OFF VALVE INSIDE PUMP BASIN ARE OPEN PRIOR TO GRINDER PUMP START-UP AND TESTING
5. CONTRACTOR SHALL DECOMMISSION EXISTING ON-LOT SEWAGE DISPOSAL FACILITIES AS FOLLOWS:  
REMOVE LID, VENT AND ACCESS COLLAR OF ALL TANKS AND/OR SEEPAGE PITS/CESSPOOLS. OBTAIN SERVICES OF SEWAGE HAULER LICENSED BY THE COUNTY AND STATE TO PUMP OUT CONTENTS AND FLUSH/SCRAPE CLEAN INTERIOR OF TANKS. DRILL OR BREAK A 6" DIAMETER MINIMUM HOLE IN THE BOTTOM OF THE TANK. FILL TANKS WITH AASHTO NO. 57 STONE TO A LEVEL 6" BELOW SURROUNDING GRADE. BACKFILL TO GRADE WITH 6" OF TOPSOIL, FINISH GRADE, SEED AND MULCH.
6. THIS DETAIL PROVIDED FOR INFORMATIONAL PURPOSES ONLY.

## TYPICAL GRINDER PUMP STATION INSTALLATION

NTS

### BUCKS COUNTY WATER & SEWER AUTHORITY

DWG. BY: TSB	CKD. BY:	TYPICAL GRINDER PUMP STATION INSTALLATION	
DATE: 7-24-19	SCALE: None		
REVISION	DATE		
RLF	3-6-26	STANDARD DETAIL	S-21

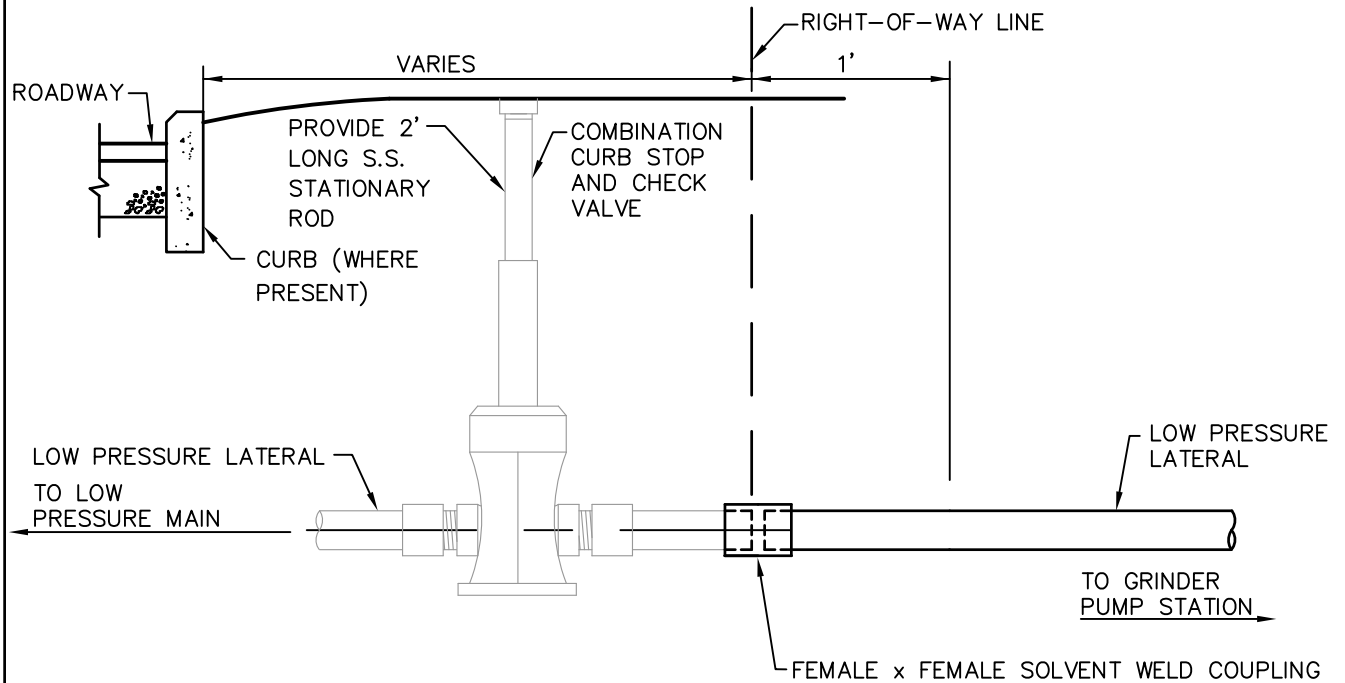

**NOTES:**

1. COMBINATION CURB STOP AND CHECK VALVE SHALL BE PLACED 1' INSIDE PROPERTY LINE.
2. PROVIDE MINIMUM COVER OF 4' WITH RESPECT TO COMBINATION CURB STOP AND CHECK VALVE.

**LOW PRESSURE LATERAL CONNECTION  
WITH CHECK VALVE**

NTS

C:\Users\rfelix\Desktop\Cad Details\SBCW-A.DWG Mar 10, 2026 10:03am

BUCKS COUNTY WATER & SEWER AUTHORITY			
DWG. BY: TSB	CKD. BY:	LOW PRESSURE SEWER LATERAL CONNECTION W/ CHECK VALVE	
DATE: 7-24-19	SCALE: None		
REVISION		DATE	
RLF		3-6-26	
STANDARD DETAIL			S-22

S:\BCWSA Standard Detail Revisions - 2022\BCW-A\SPEC\SBCW-A.DWG Apr 06, 2022 11:00am

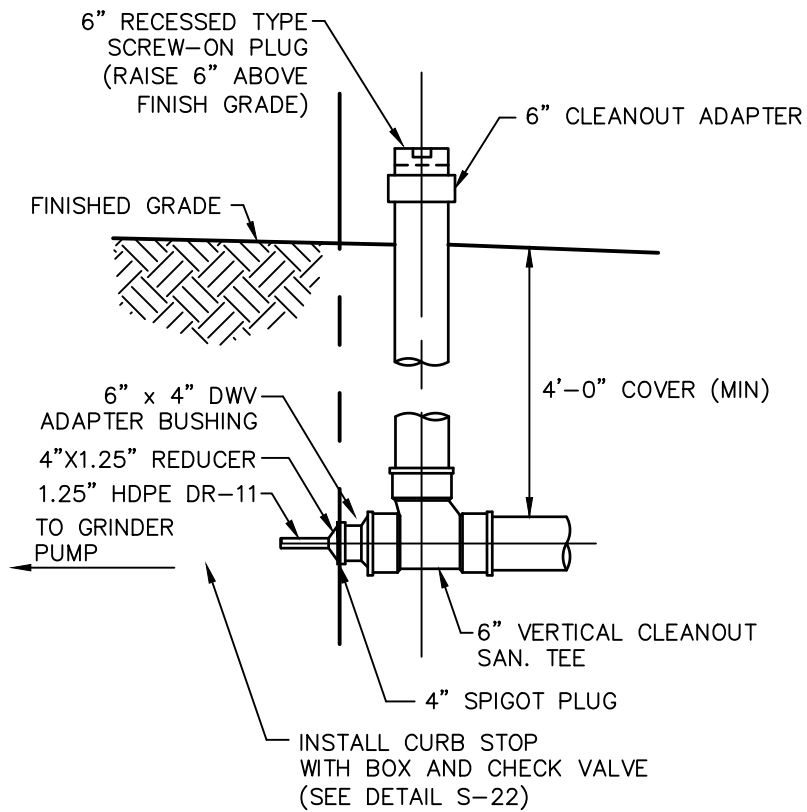

ELEVATION

**LOW PRESSURE SEWER CONNECTION  
(RESIDENTIAL FORCE MAIN TO GRAVITY LATERAL CONNECTION)**

NTS

BUCKS COUNTY WATER & SEWER AUTHORITY			
DWG. BY: TSB	CKD. BY:	LOW PRESSURE SEWER CONNECTION (RESIDENTIAL FORCE MAIN TO GRAVITY LATERAL CONNECTION)	
DATE: 7-24-19	SCALE: None		
REVISION		DATE	
KTI		4/6/22	
		STANDARD DETAIL S-23	

S:\mydocs\BCWSA Standard Detail Revisions\BCW-A\SPEC\SBCW-A.DWG Nov 25, 2019 2:54pm

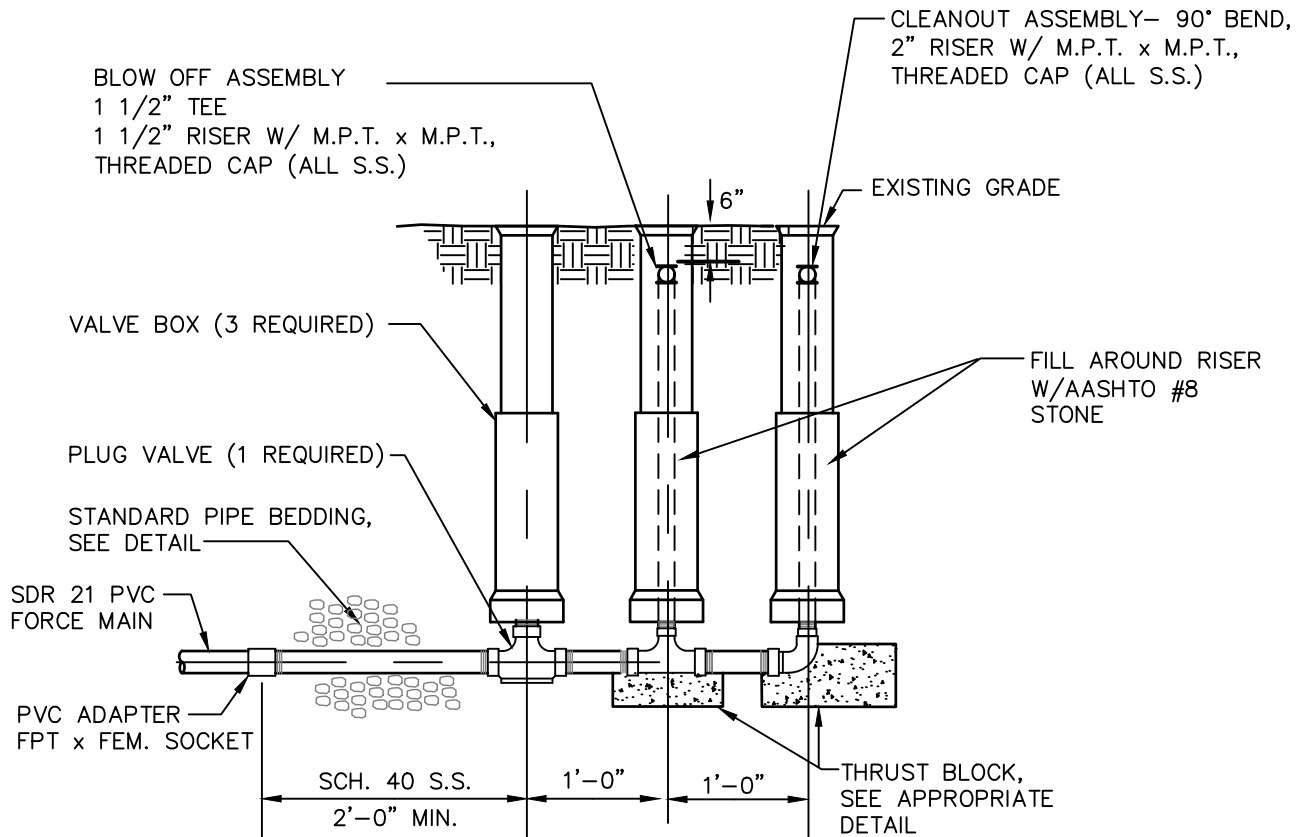

**NOTE:**

SUPPORT VALVE BOXES ON SOLID CONCRETE BLOCKS, MORTARED IN PLACE, EXTENDING DOWN TO UNDISTURBED EARTH.  
 PROVIDE BRICK MASONRY SUPPORT BENEATH VALVE, EXTENDING DOWN TO UNDISTURBED EARTH.

**LOW PRESURE SEWER TERMINAL CLEANOUT**

NTS

BUCKS COUNTY WATER & SEWER AUTHORITY			
DWG. BY: TSB	CKD. BY:	LOW PRESSURE SEWER TERMINAL CLEANOUT	
DATE: 7-24-19	SCALE: None		
REVISION	DATE		
		STANDARD DETAIL	S-24

S:\mydocs\BCWSA Standard Detail Revisions\BCW-A\SPEC\SBCW-A.DWG Nov 25, 2019 2:54pm

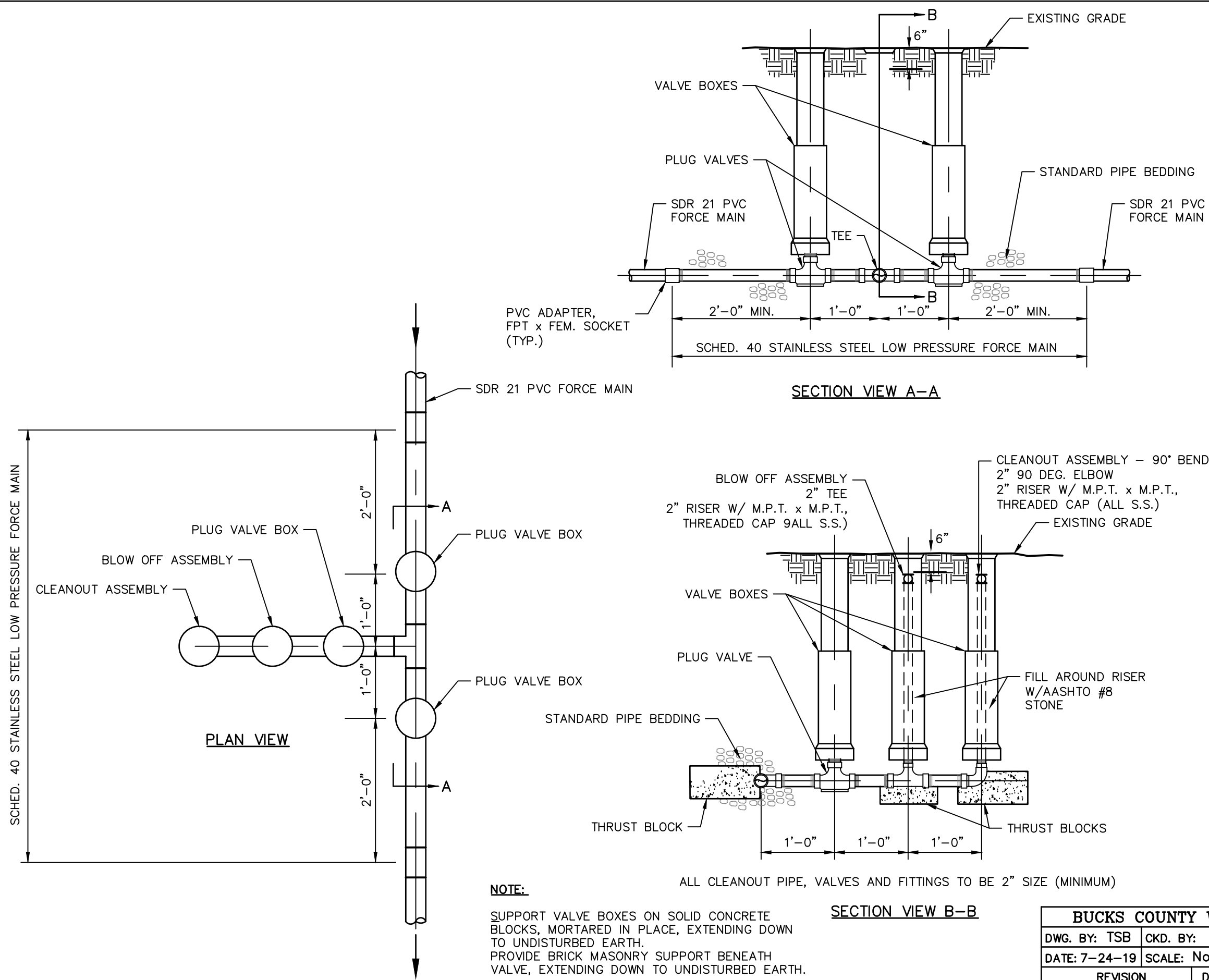

**NOTE:**

SUPPORT VALVE BOXES ON SOLID CONCRETE BLOCKS, MORTARED IN PLACE, EXTENDING DOWN TO UNDISTURBED EARTH.  
PROVIDE BRICK MASONRY SUPPORT BENEATH VALVE, EXTENDING DOWN TO UNDISTURBED EARTH.

ALL CLEANOUT PIPE, VALVES AND FITTINGS TO BE 2" SIZE (MINIMUM)

**LOW PRESSURE SEWER IN-LINE CLEANOUT**

NTS

BUCKS COUNTY WATER & SEWER AUTHORITY			
DWG. BY: TSB	CKD. BY:	LOW PRESSURE SEWER IN-LINE CLEANOUT	
DATE: 7-24-19	SCALE: None		
REVISION	DATE	STANDARD DETAIL S-25	

S:\mydocs\BCWSA Standard Detail Revisions\BCW-A\SPEC\SBCW-A.DWG Nov 25, 2019 2:54pm

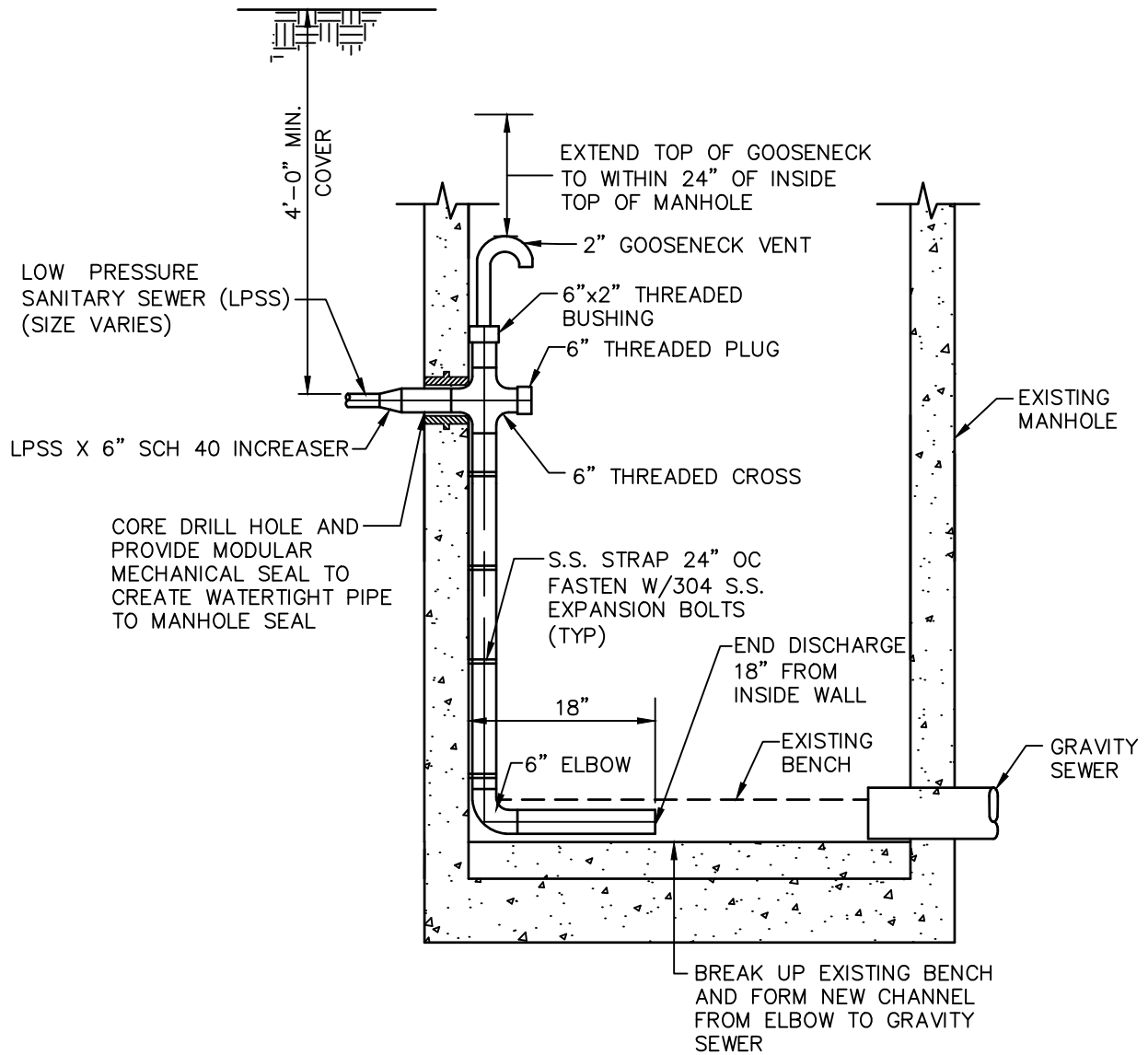

**NOTE:**

ALL PIPE INSIDE MANHOLE TO BE SCHEDULE 40 PVC.

**LOW PRESSURE SEWER DROP CONNECTION  
IN EXISTING MANHOLE**

NTS

BUCKS COUNTY WATER & SEWER AUTHORITY			
DWG. BY: TSB	CKD. BY:	LOW PRESSURE SEWER DROP CONNECTION IN EXISTING MANHOLE	
DATE: 7-24-19	SCALE: None		
REVISION	DATE	STANDARD DETAIL S-26	

C:\Users\kiasiello.CORP\OneDrive - Carroll Engineering\BCWSA Standard Detail Revisions - 2022\BCW-A\SPEC\BCW-A.DWG May 25, 2022 11:33am

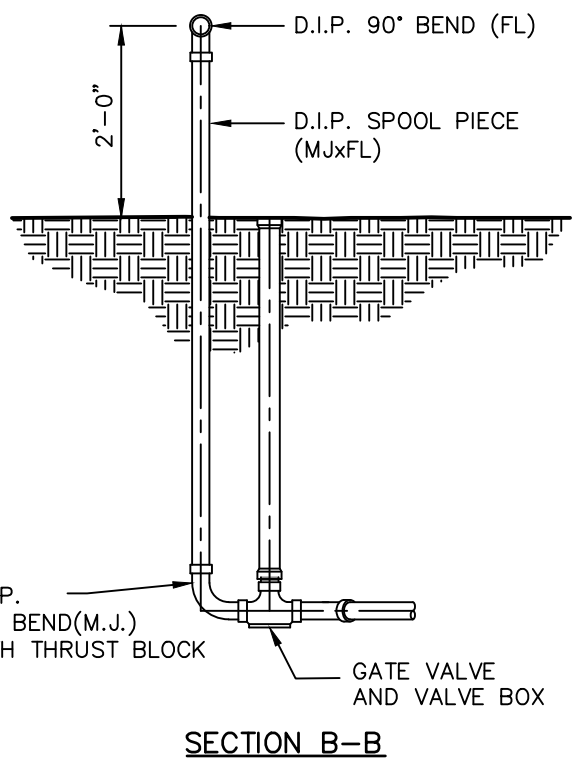
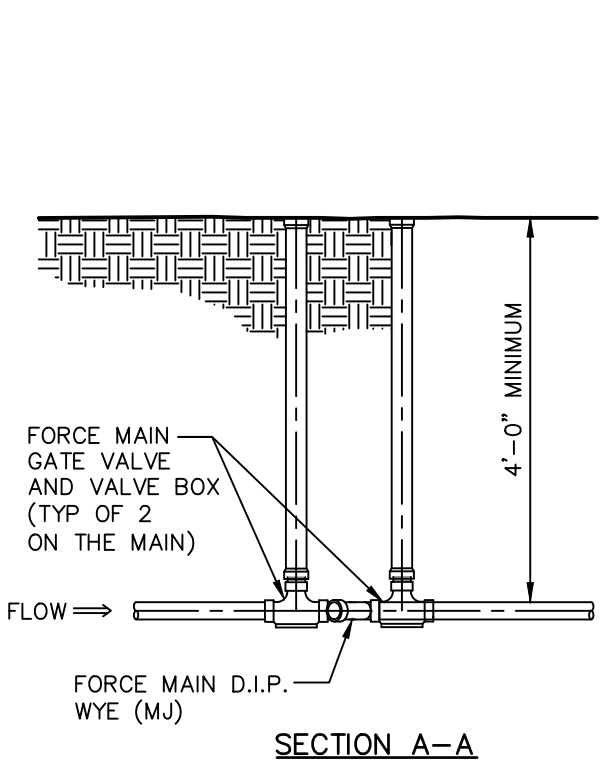
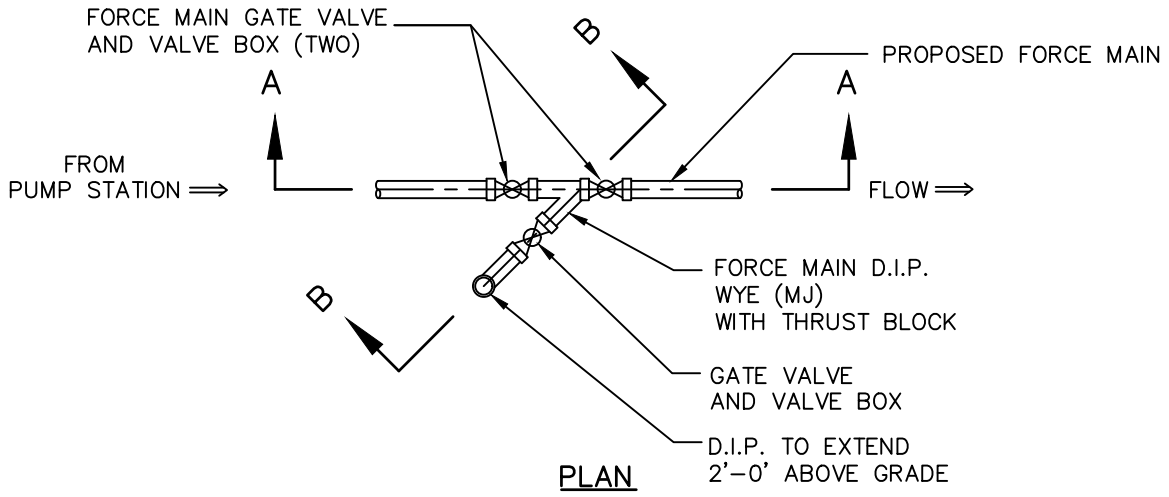

**NOTES:**

1. VALVE BOXES TO BE SUPPLIED WITH LIDS MARKED "SEWER".
2. ABOVE GRADE TERMINAL END TO BE CAPPED WITH CONNECTION HARDWARE TO BE SUPPLIED BY OWNER. CONTRACTOR TO TEMPORARILY PROTECT OPEN END OF BEND FROM DEBRIS UNTIL CONNECTION HARDWARE IS SUPPLIED AND INSTALLED.
3. QUICK CONNECT PIPING TO GENERALLY BE SIZED AT 6-INCH DIAMETER PIPE, VALVE, AND FITTINGS, UNLESS OTHERWISE APPROVED BY BCWSA.
4. PROTECT WITH BOLLARDS AS REQUIRED.

**QUICK CONNECT**

NTS

BUCKS COUNTY WATER & SEWER AUTHORITY			
DWG. BY: TSB	CKD. BY:	QUICK CONNECT	
DATE: 4-6-22	SCALE: None		
REVISION	DATE		
		STANDARD DETAIL	S-27

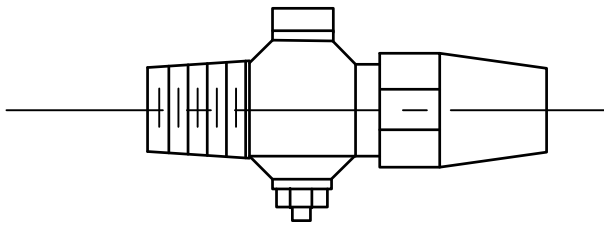

**CORPORATION STOP MUELLER B-25008N**  
**OR APPROVED EQUAL**

(FOR PVC SADDLE SEE SPECIFICATIONS)

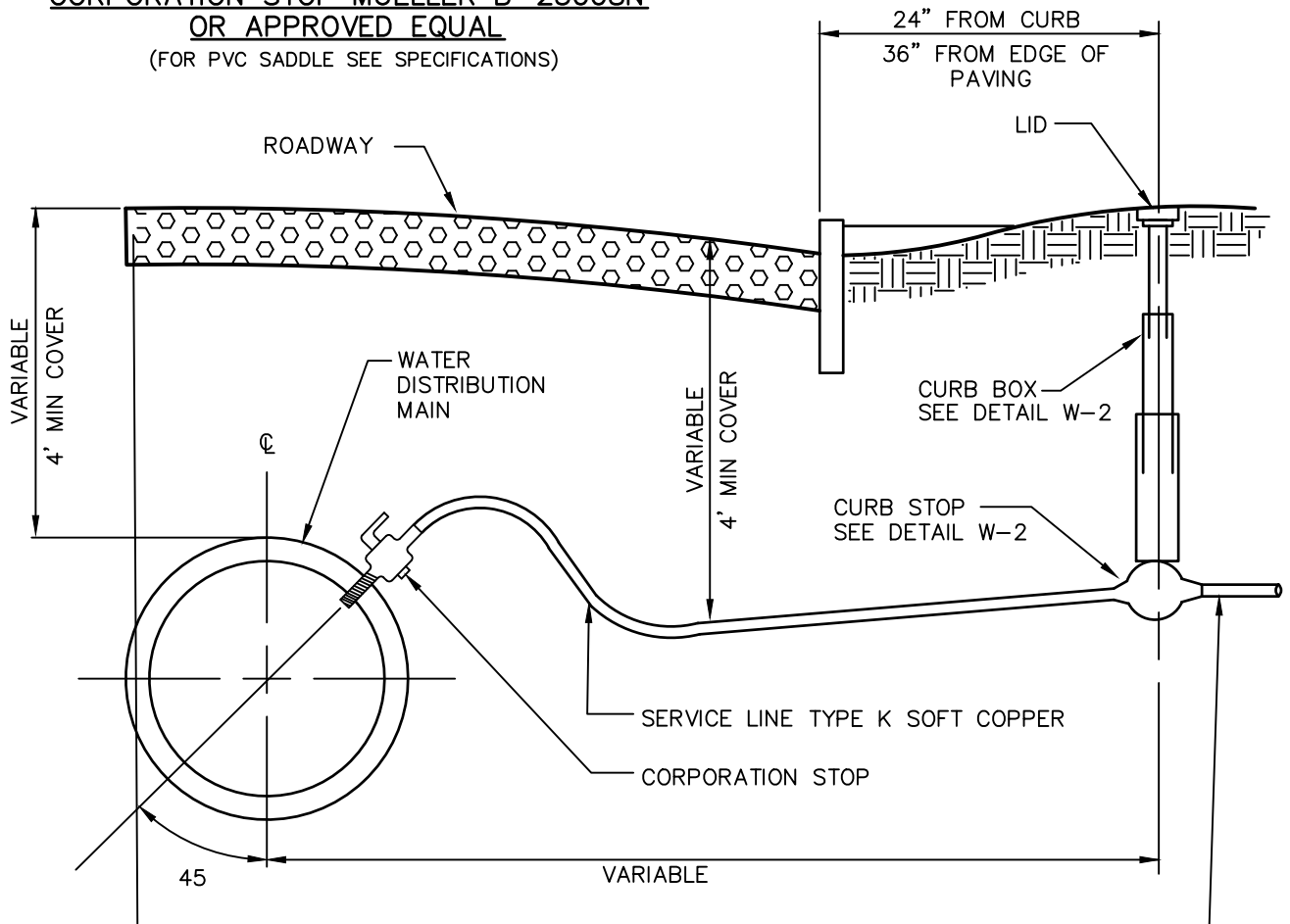

**NOTES:**

FOR STANDARD 3/4" CONNECTION, INSERT A TAPPED COUPLING WITH THREADED INSERT OR DOUBLE-STRAPPED SADDLE CLAMP ON THE WATER MAIN.

CUSTOMER TO CONNECT AT THIS POINT

**SERVICE CONNECTION**

NTS

S:\mydocs\BCWSA Standard Detail Revisions\BCW-B\SPEC\SBCW-B.DWG Nov 25, 2019 2:20pm

BUCKS COUNTY WATER & SEWER AUTHORITY			
DWG. BY: TSB	CKD. BY:	SERVICE CONNECTION	
DATE: 7-24-19	SCALE: None		
REVISION	DATE	STANDARD DETAIL W-1	

S:\mydocs\BCWSA Standard Detail Revisions\BCW-B\SPEC\SBCW-B.DWG Nov 25, 2019 2:20pm

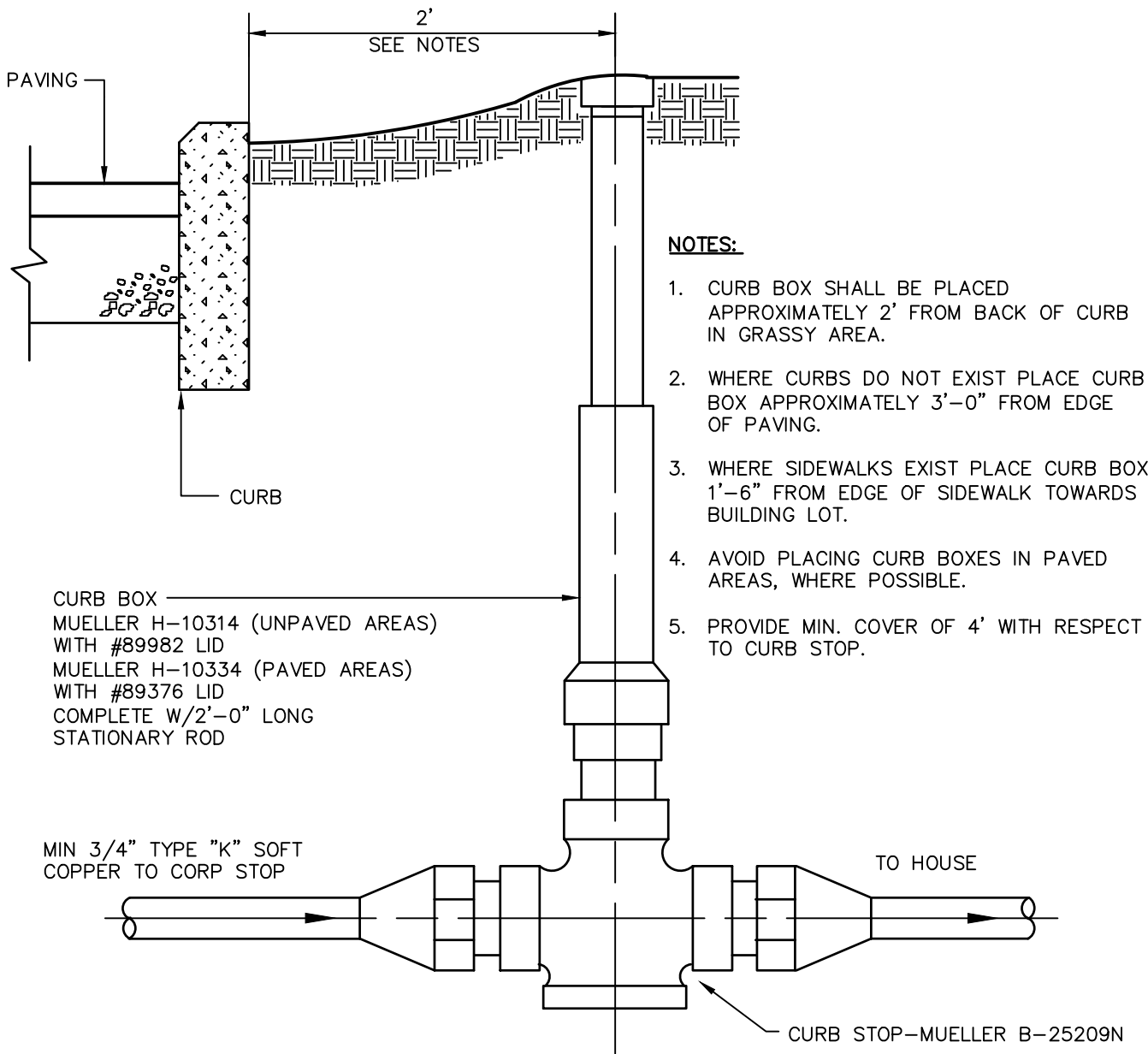

- NOTES:**
1. CURB BOX SHALL BE PLACED APPROXIMATELY 2' FROM BACK OF CURB IN GRASSY AREA.
  2. WHERE CURBS DO NOT EXIST PLACE CURB BOX APPROXIMATELY 3'-0" FROM EDGE OF PAVING.
  3. WHERE SIDEWALKS EXIST PLACE CURB BOX 1'-6" FROM EDGE OF SIDEWALK TOWARDS BUILDING LOT.
  4. AVOID PLACING CURB BOXES IN PAVED AREAS, WHERE POSSIBLE.
  5. PROVIDE MIN. COVER OF 4' WITH RESPECT TO CURB STOP.

CURB BOX  
 MUELLER H-10314 (UNPAVED AREAS)  
 WITH #89982 LID  
 MUELLER H-10334 (PAVED AREAS)  
 WITH #89376 LID  
 COMPLETE W/2'-0" LONG  
 STATIONARY ROD

MIN 3/4" TYPE "K" SOFT  
 COPPER TO CORP STOP

TO HOUSE

CURB STOP-MUELLER B-25209N

**TYPICAL CURB STOP & VALVE BOX**

NTS

BUCKS COUNTY WATER & SEWER AUTHORITY			
DWG. BY: TSB	CKD. BY:	TYPICAL CURB STOP & VALVE BOX	
DATE: 7-24-19	SCALE: None		
REVISION	DATE	STANDARD DETAIL W-2	

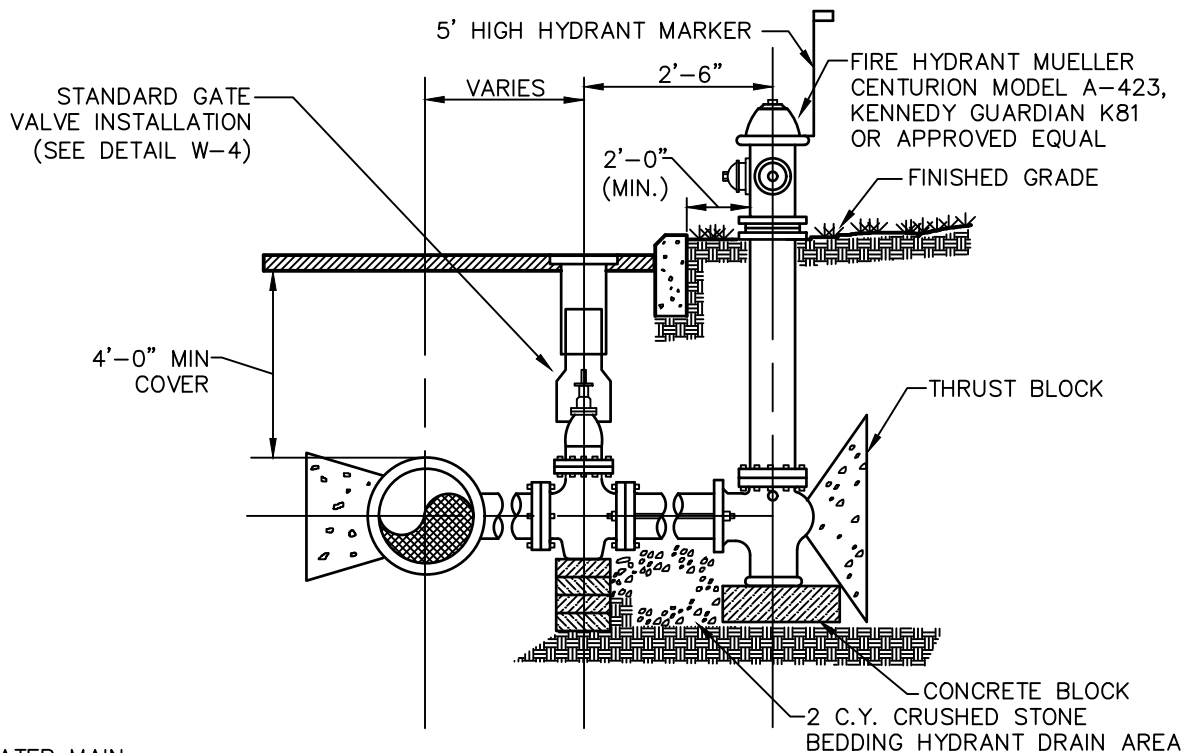

**ELEVATION**

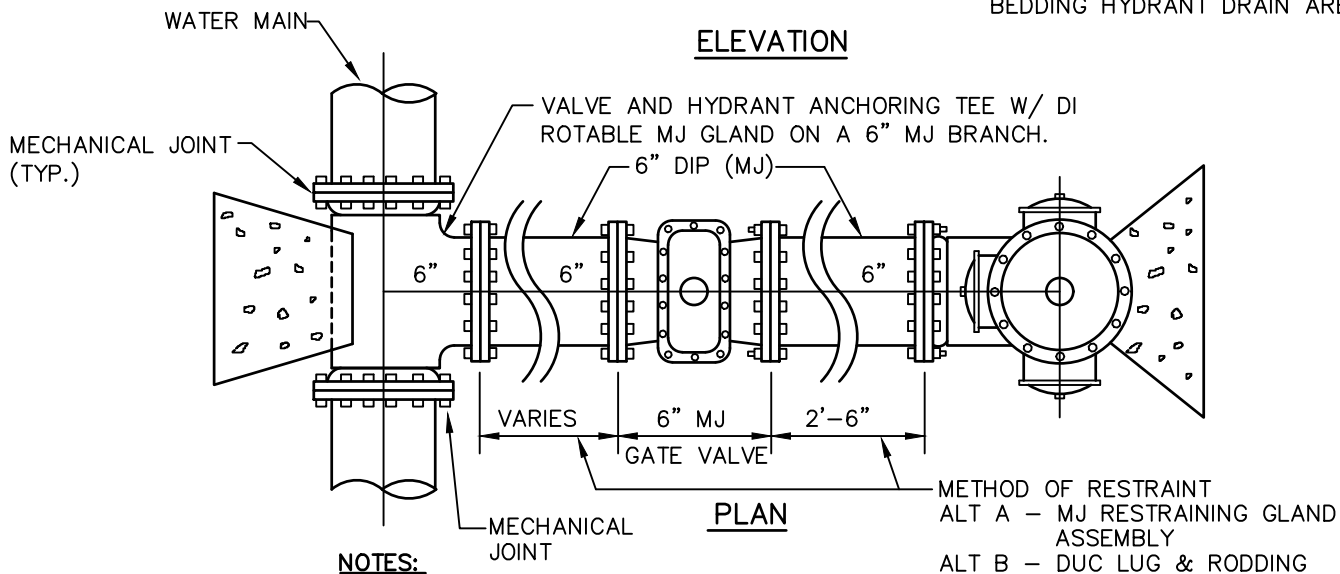

**PLAN**

**NOTES:**

1. A MIN. COVER OF FIVE FEET WITH RESPECT TO HYDRANT LOCATION SHALL BE PROVIDED WITH THE NECESSARY BENDS, FITTINGS AND RESTRAINTS AS DIRECTED BY THE AUTHORITY'S ENGINEER.
2. THRUST BLOCKS TO BE PROVIDED IN ADDITION TO MECHANICAL RESTRAINTS.

**FIRE HYDRANT CONNECTION**

NTS

S:\mydocs\BCWSA Standard Detail Revisions\BCW-B\SPEC\SBCW-B.DWG Nov 25, 2019 2:20pm

BUCKS COUNTY WATER & SEWER AUTHORITY			
DWG. BY: TSB	CKD. BY:	FIRE HYDRANT CONNECTION	
DATE: 7-24-19	SCALE: None		
REVISION	DATE	STANDARD DETAIL W-3	



COVER DETAIL

BUFFALO TYPE THREE-PIECE  
CAST IRON VALVE BOX  
ASSEMBLY WITH ROUND BASE  
BITUMINOUS COATED OR  
APPROVED EQUAL

CAST IRON COVER  
SEE DETAIL

AWWA C-509  
GATE VALVE  
(SEE SPECIFICATION  
SECTION 02660)

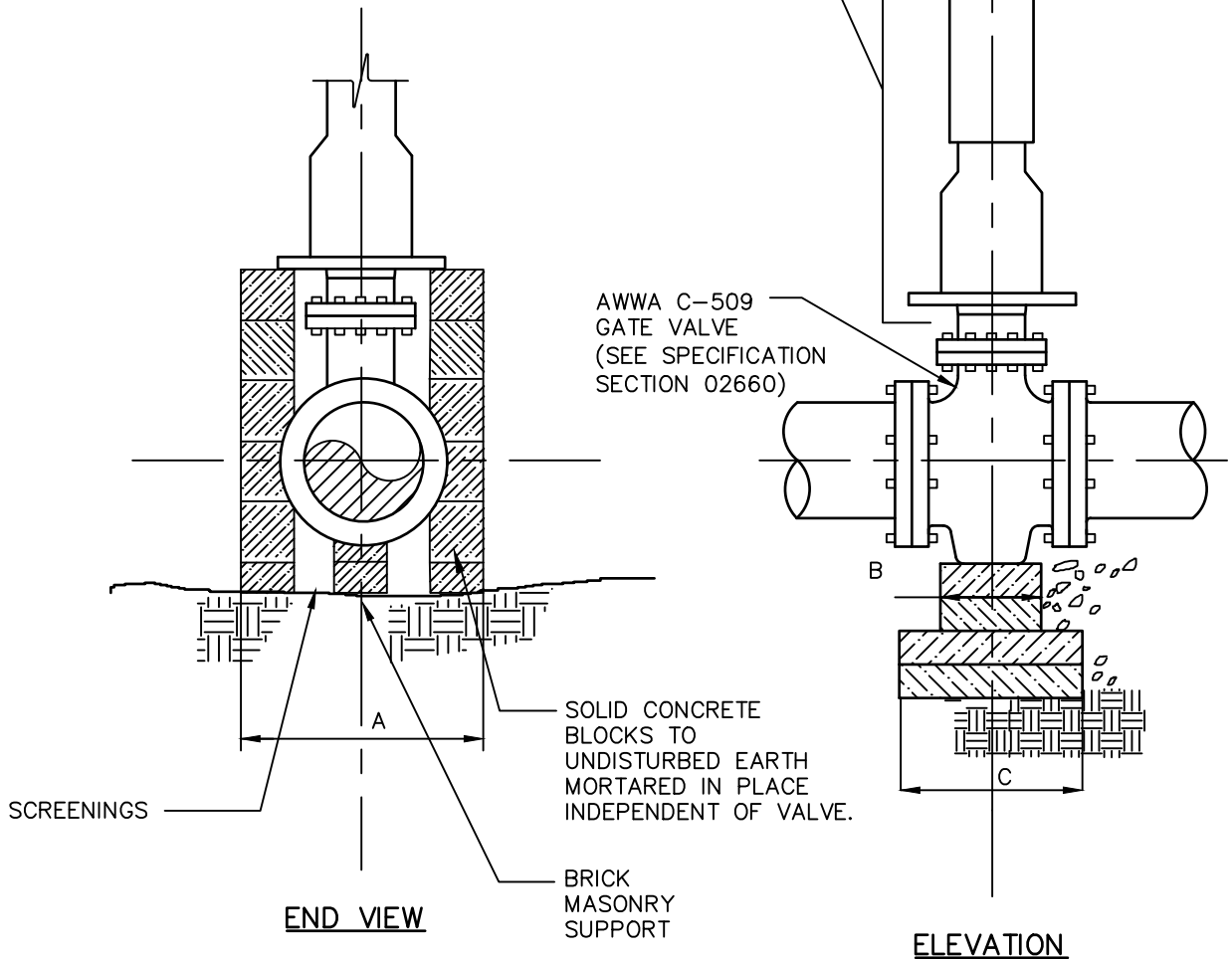

**TYPICAL GATE VALVE WITH VALVE BOX**

NTS

SIZE OF VALVE	DIMENSIONS		
	A	B	C
12"	24	8	14
10"	24	8	14
8"	20	6	12
6"	8	4	10
4"	8	4	10

BUCKS COUNTY WATER & SEWER AUTHORITY			
DWG. BY: TSB	CKD. BY:	TYPICAL GATE VALVE WITH VALVE BOX	
DATE: 7-24-19	SCALE: None		
REVISION	DATE	STANDARD DETAIL W-4	

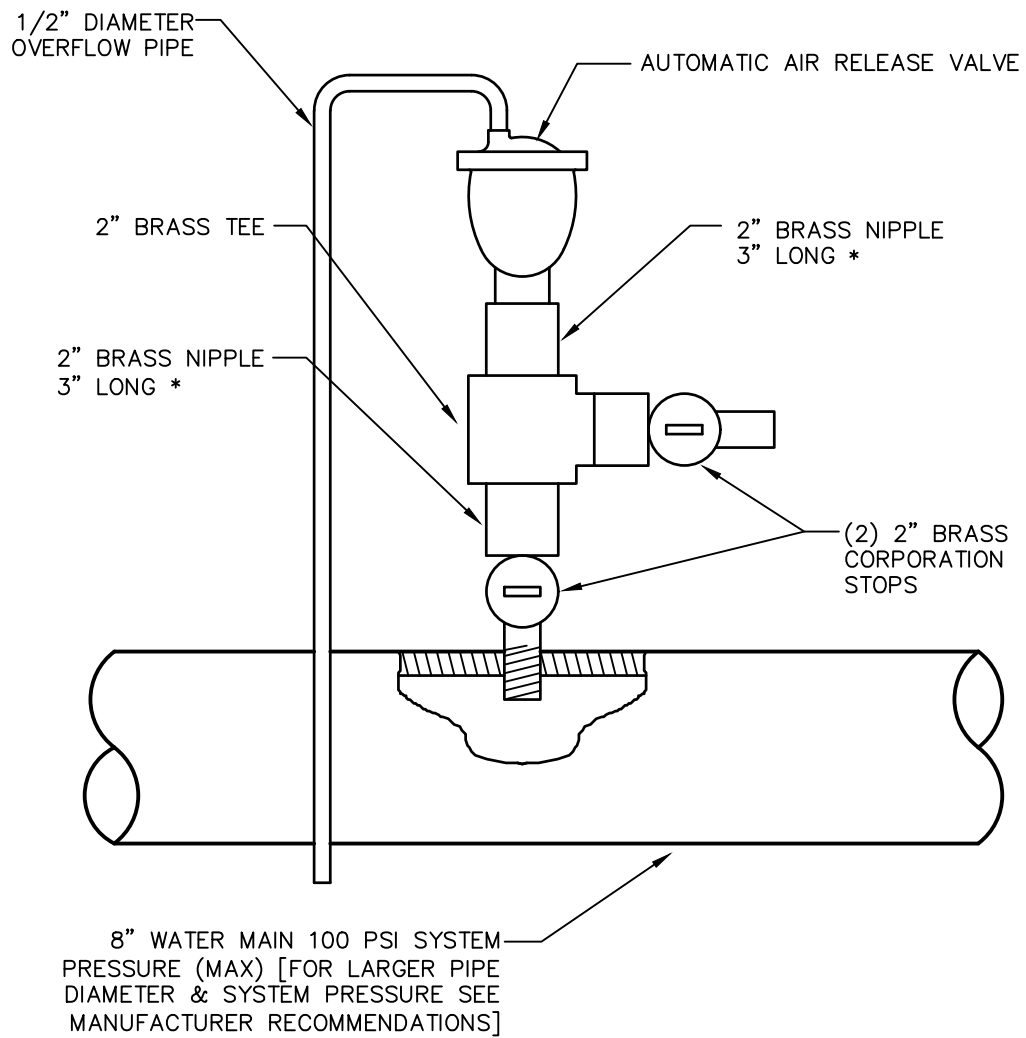

## AIR RELEASE VALVE

NTS

**NOTE:** SEE W-6 FOR AIR VALVE MANHOLE DETAIL

\* DIMENSIONS MAY VARY DEPENDING ON MATERIALS FURNISHED

<b>BUCKS COUNTY WATER &amp; SEWER AUTHORITY</b>			
DWG. BY: TSB	CKD. BY:	<b>AIR RELEASE VALVE</b>	
DATE: 7-24-19	SCALE: None		
REVISION	DATE	<b>STANDARD DETAIL      W-5</b>	

HEAVY DUTY TRAFFIC TYPE (HS-20)  
 MANHOLE FRAME & COVER (VENTED)  
 ADJUST TO GRADE AS REQUIRED

4'-0" DIA FOR 8" TO 12" PIPE  
 5'-0" DIA FOR 16" TO 24" PIPE  
 6'-0" DIA FOR 30" TO 36" PIPE

PROVIDE VENT  
 PIPING TO ABOVE  
 GRADE IF  
 REQUIRED BY  
 AUTHORITY

**NOTE:**

MANHOLE SHALL BE CONSTRUCTED IN  
 ACCORDANCE WITH DETAILS S-1 AND S-2.

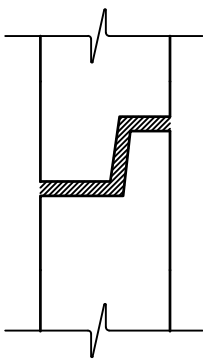
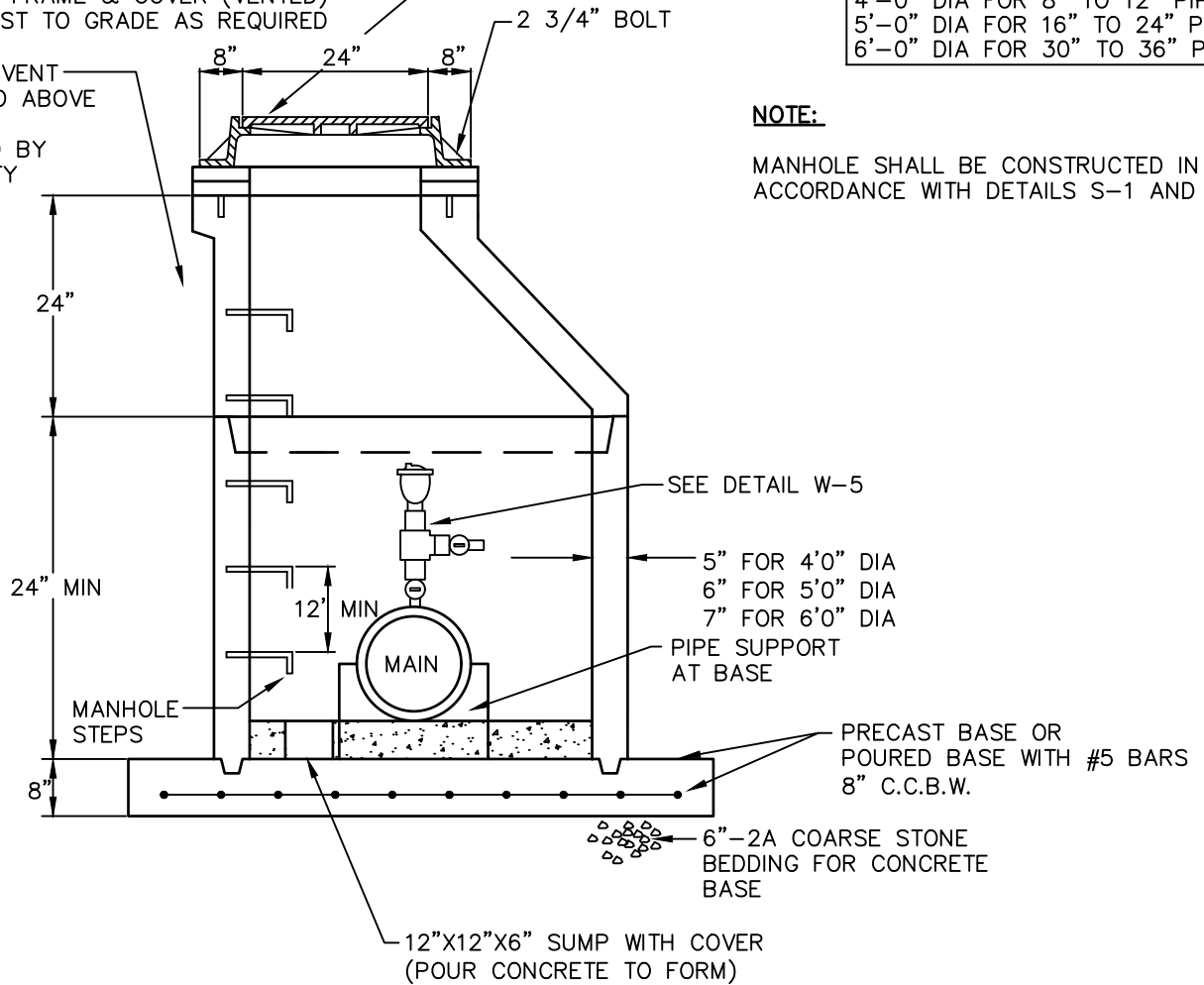

**MANHOLE JOINT**

DOUBLE RING OF PREFORMED PLASTIC JOINT  
 SEALANT - BUTYL LOK OR APPROVED EQUAL

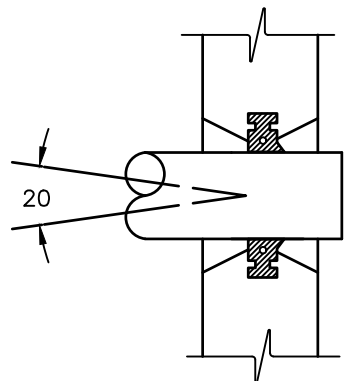

**PIPE TO MANHOLE SEAL**

A-LOK GASKET PER A.S.T.M. RUBBER  
 GASKET SPEC. C443, CAST INTEGRALLY  
 IN MANHOLE WALL AND LOCATED AS  
 REQUIRED.

**AIR RELEASE VALVE MANHOLE**

NTS

S:\mydocs\BCWSA Standard Detail Revisions\BCW-B\SPEC\SBCW-B.DWG Nov 25, 2019 2:21pm

BUCKS COUNTY WATER & SEWER AUTHORITY			
DWG. BY: TSB	CKD. BY:	AIR RELEASE VALVE MANHOLE	
DATE: 7-24-19	SCALE: None		
REVISION	DATE	STANDARD DETAIL W-6	

S:\BCWSA Standard Detail Revisions - 2022\BCW-B\SPEC\SBCW-B.DWG Apr 14, 2022 1:41pm

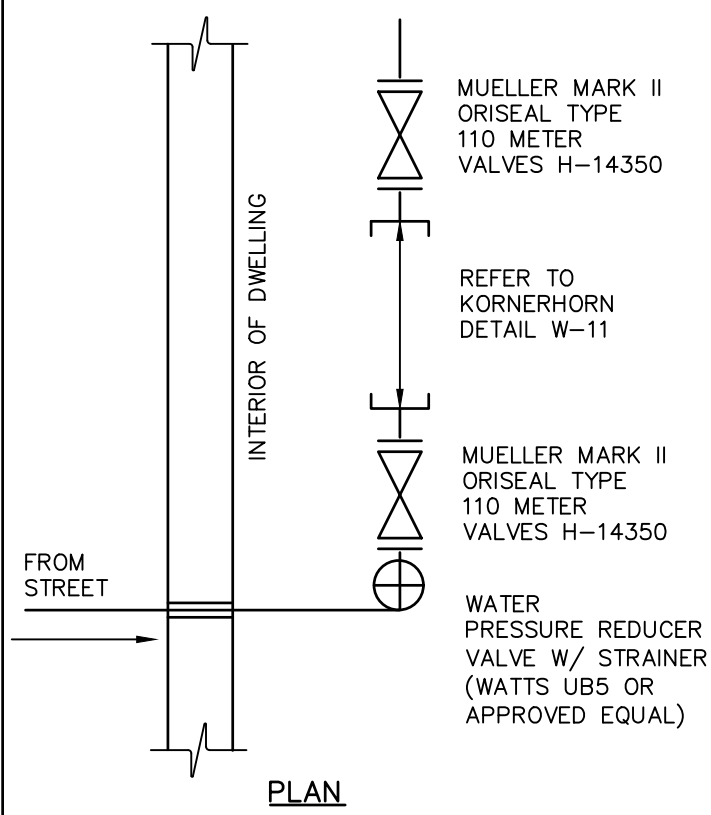

**NOTES :**

1. NOTIFY AUTHORITY AT (215)343-2538 WHEN WATER SERVICE IS READY FOR INSPECTION & TEST. DO NOT BACKFILL TRENCH UNTIL INSPECTION IS COMPLETED.
2. AUTHORITY WILL INSTALL METER.
3. PRESSURE REDUCING VALVES TO BE INSTALLED BY PLUMBER ON ALL MAINS HAVING A PRESSURE OF 65 P.S.I. OR GREATER.
4. LOCATION OF METER TO BE APPROVED BY AUTHORITY.
5. ALL SERVICE LINES SHALL BE A MINIMUM OF 3/4" TYPE K COPPER TUBING, INSTALLED AS A CONTINUOUS ROLL WITHOUT COUPLINGS.

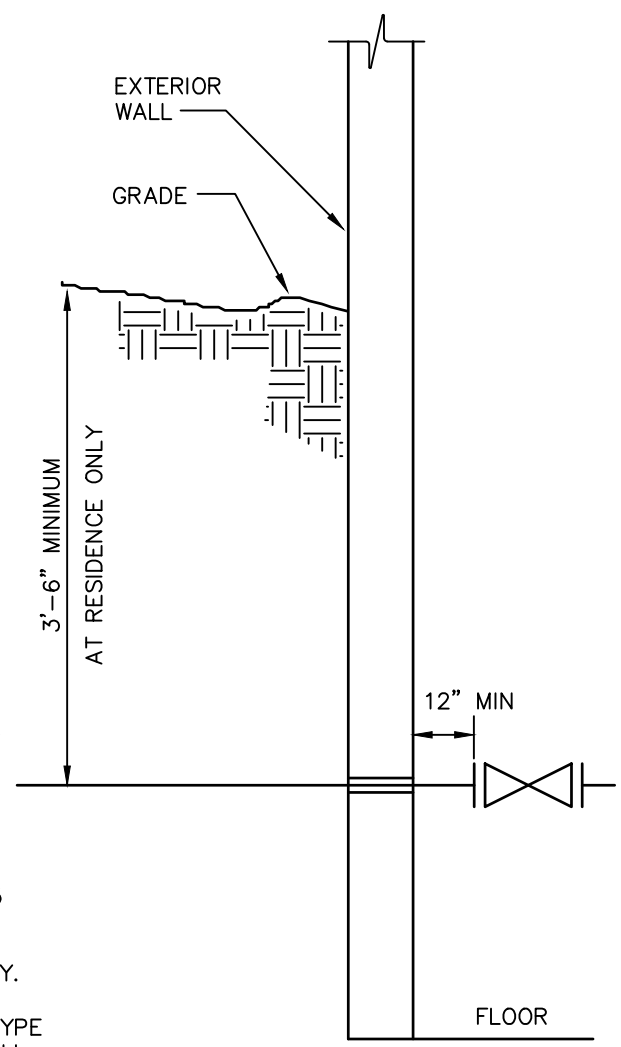

**RESIDENTIAL METER INSTALLATION**

NTS

BUCKS COUNTY WATER & SEWER AUTHORITY			
DWG. BY: TSB	CKD. BY:	RESIDENTIAL METER INSTALLATION	
DATE: 7-24-19	SCALE: None		
REVISION	DATE	STANDARD DETAIL W-7	
KTI	4/6/22		

S:\mydocs\BCWSA Standard Detail Revisions\BCW-B\SPEC\SBCW-B.DWG Nov 25, 2019 2:21pm

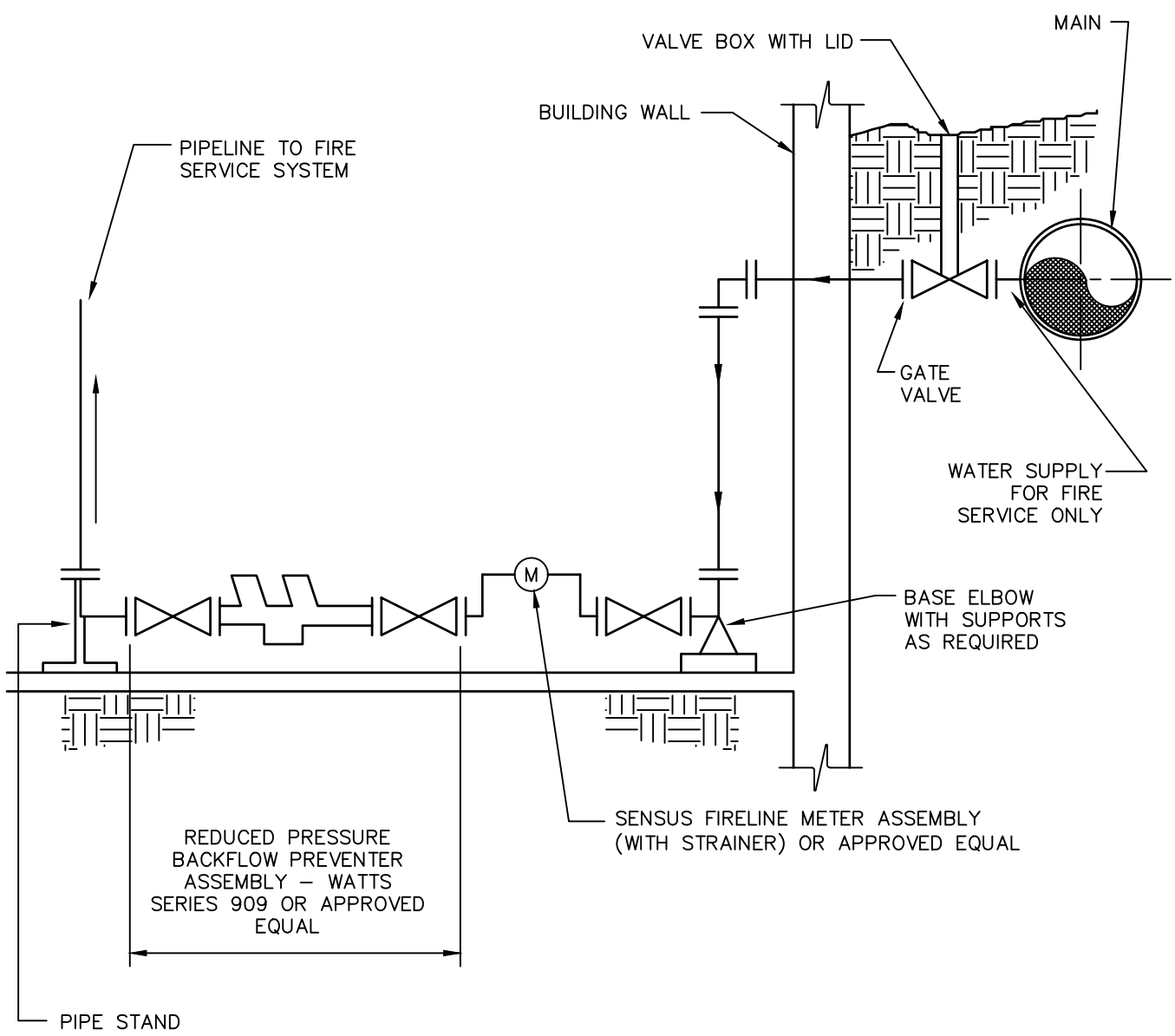

## BACKFLOW PREVENTER FOR PRIVATE FIRE SERVICE

NTS

BUCKS COUNTY WATER & SEWER AUTHORITY			
DWG. BY: TSB	CKD. BY:	BACKFLOW PREVENTER FOR PRIVATE FIRE SERVICE	
DATE: 7-24-19	SCALE: None		
REVISION	DATE		
		STANDARD DETAIL	W-8

S:\mydocs\BCWSA Standard Detail Revisions\BCW-B\SPEC\SBCW-B.DWG Nov 25, 2019 2:21pm

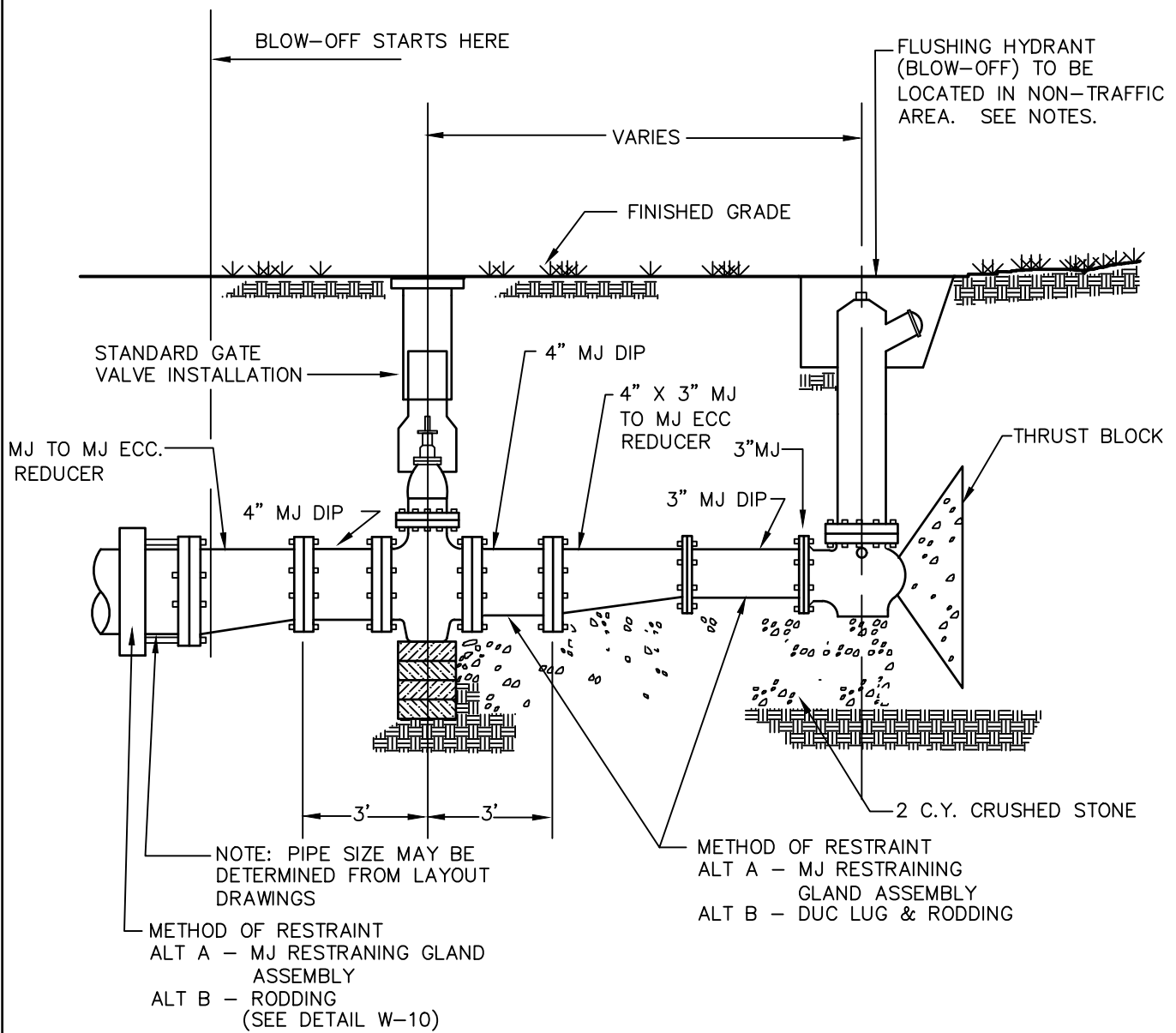

**ELEVATION  
END OF RUN INSTALLATION**

**NOTES:**

1. FLUSHING HYDRANT SHALL BE MUELLER MODEL A-412, SIZE 2 1/8", WITH (1) 2" NOZZLE AND CAP CHAIN FURNISHED WITH WRENCH CAT. NO. A-313 OR APPROVED EQUAL. INLET 3" MECHANICAL JOINT.
2. WHERE A FLUSHING HYDRANT IS LOCATED ON A BRANCH MAIN, THE INSTALLATION SHALL BE SIMILAR TO THE STANDARD FIRE HYDRANT DETAILS.
3. FIRE HYDRANTS TO BE PROVIDED IN LIEU OF BLOW-OFF ASSEMBLIES WHERE POSSIBLE.

**BLOW OFF ASSEMBLY**

NTS

BUCKS COUNTY WATER & SEWER AUTHORITY			
DWG. BY: TSB	CKD. BY:	BLOW-OFF ASSEMBLY	
DATE: 7-24-19	SCALE: None		
REVISION	DATE	STANDARD DETAIL W-9	

S:\mydocs\BCWSA Standard Detail Revisions\BCW-B\SPEC\SBCW-B.DWG Nov 25, 2019 2:21pm

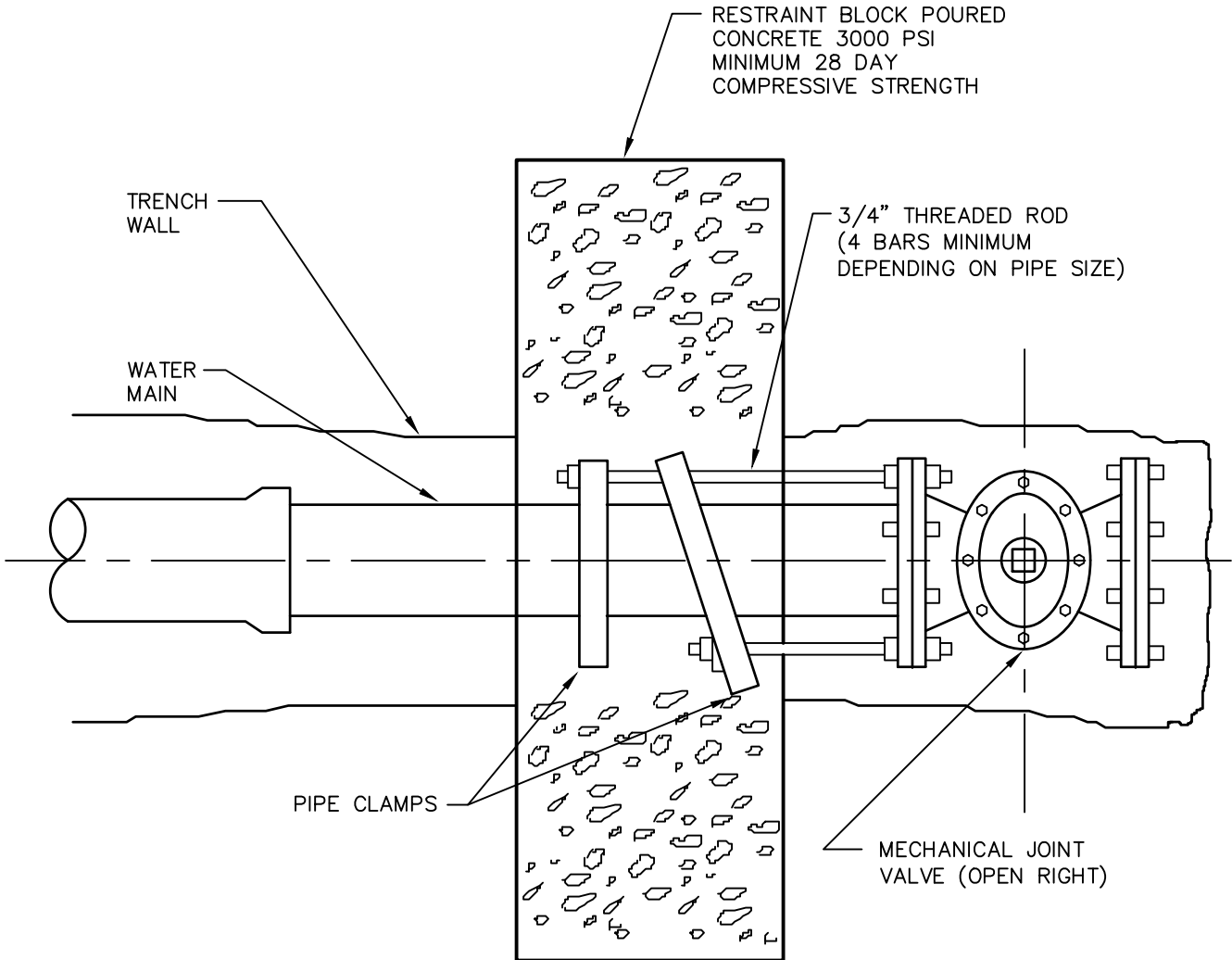

**NOTES:**

1. SIZE OF RESTRAINT BLOCK TO ACCOMODATE SOIL CONDITIONS AND PIPE PRESSURE
2. LOCK NUTS TO BE USED ON ALL THREADED RODS.
3. HOT ENAMEL OR EPOXY COATING TO BE USED ON EXPOSED STEEL.

**VALVE RODDED AT DEAD END**

NTS

BUCKS COUNTY WATER & SEWER AUTHORITY			
DWG. BY: TSB	CKD. BY:	VALVE RODDED AT DEAD END	
DATE: 7-24-19	SCALE: None		
REVISION	DATE	STANDARD DETAIL W-10	

S:\mydocs\BCWSA Standard Detail Revisions\BCW-B\SPEC\SBCW-B.DWG Nov 25, 2019 2:21pm

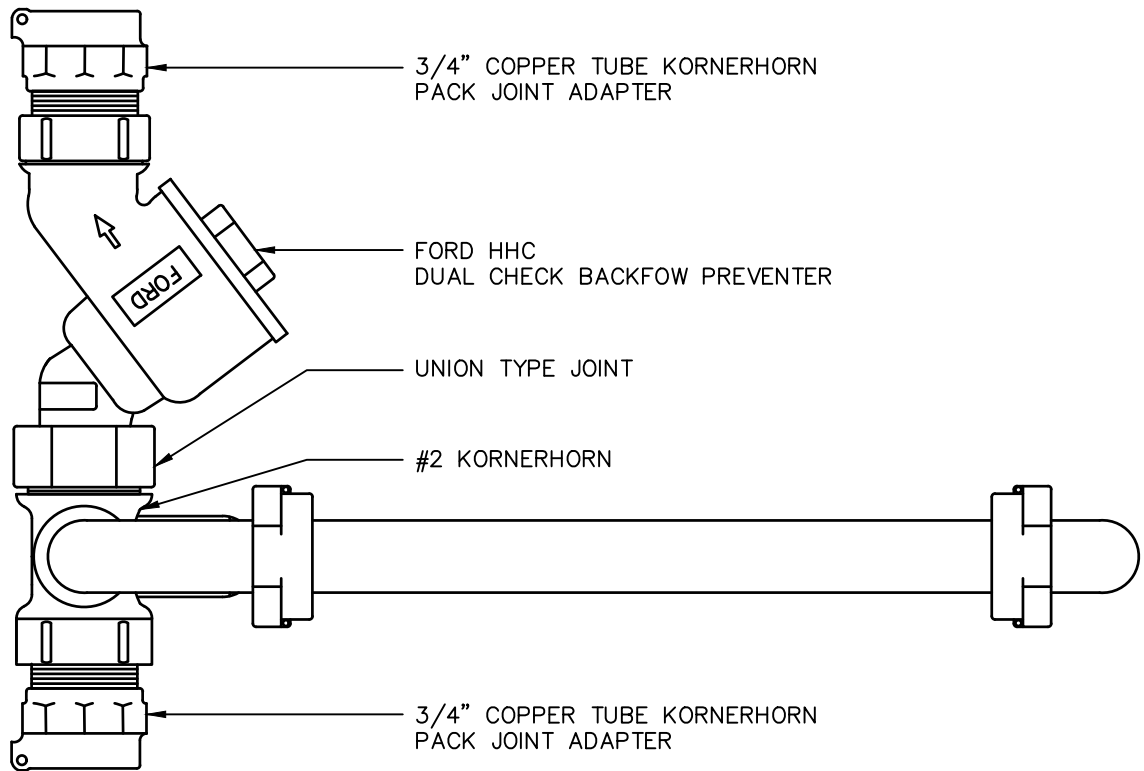

**KORNERHORN DETAIL**

NTS

BUCKS COUNTY WATER & SEWER AUTHORITY			
DWG. BY: TSB	CKD. BY:	KORNERHORN DETAIL	
DATE: 7-24-19	SCALE: None		
REVISION	DATE	STANDARD DETAIL W-11	

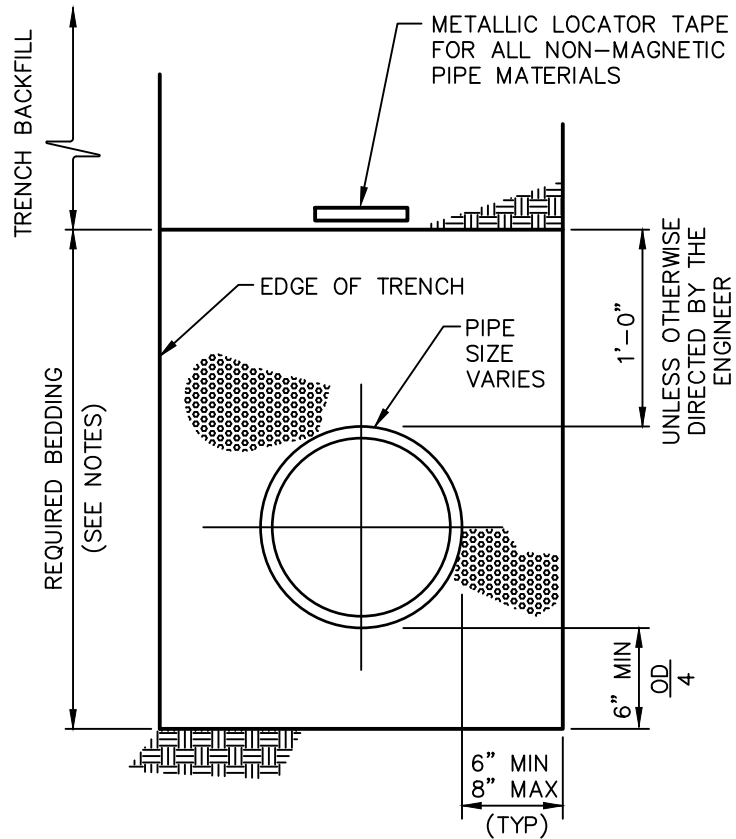

**NOTES:**

1. AASHTO NO. 8 (1B) COARSE AGGREGATE FOR PVC PIPE.
2. PADOT 2A MODIFIED AGGREGATE FOR DUCTILE IRON PIPE AND C-900 PIPE.

**STANDARD PIPE BEDDING**

NTS

BUCKS COUNTY WATER & SEWER AUTHORITY			
DWG. BY: TSB	CKD. BY:	STANDARD PIPE BEDDING	
DATE: 7-24-19	SCALE: None		
REVISION		DATE	
KTI		4/6/22	
		STANDARD DETAIL	M-1

S:\mydocs\BCWSA Standard Detail Revisions\BCW-M\SPEC\SBCW-M.DWG Nov 25, 2019 2:37pm

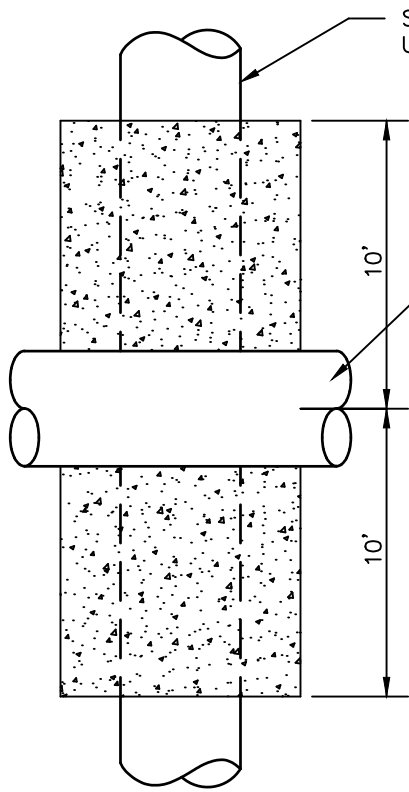

WATER CROSSINGS

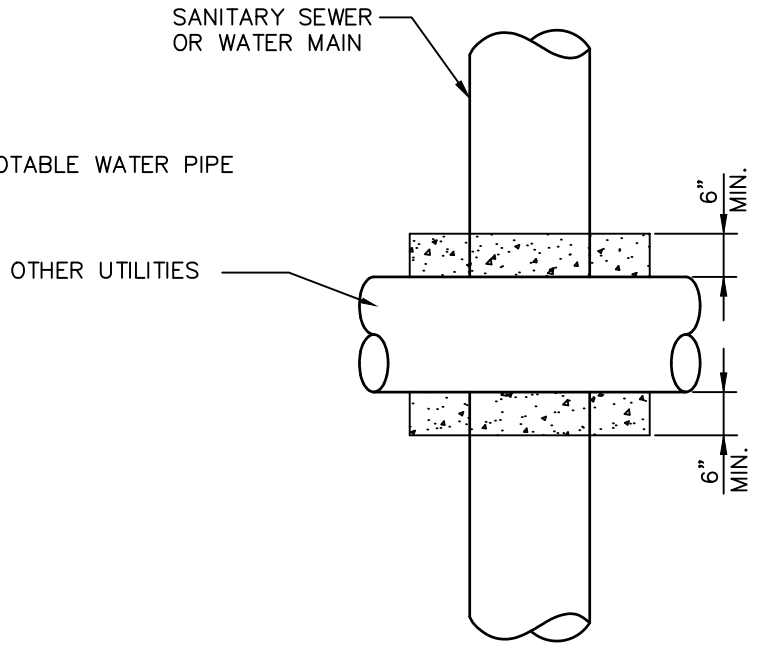

UTILITY CROSSINGS

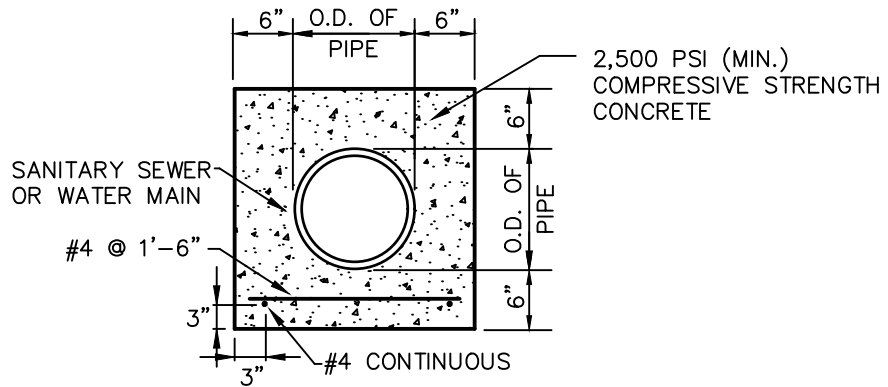

ENCASEMENT SECTION

**NOTE:**

PROVIDE REINFORCEMENT AT UTILITY CROSSINGS OR AS DIRECTED BY AUTHORITY'S ENGINEER.

**CONCRETE ENCASEMENT**

NTS

BUCKS COUNTY WATER & SEWER AUTHORITY			
DWG. BY: TSB	CKD. BY:	CONCRETE ENCASEMENT	
DATE: 7-24-19	SCALE: None		
REVISION	DATE	STANDARD DETAIL M-2	

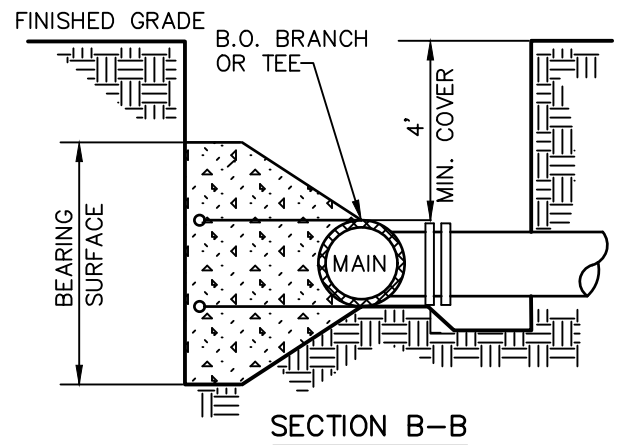
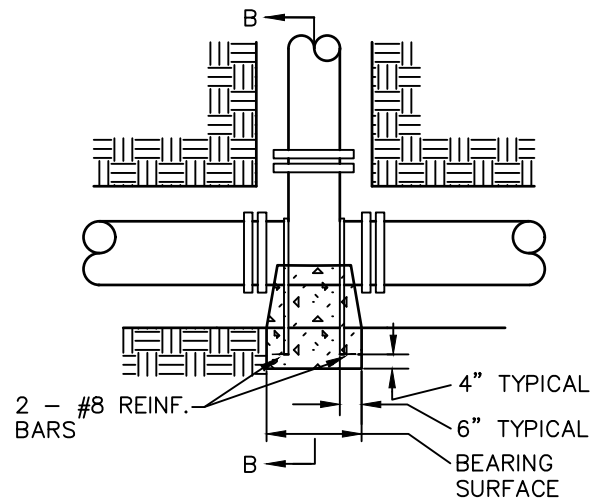
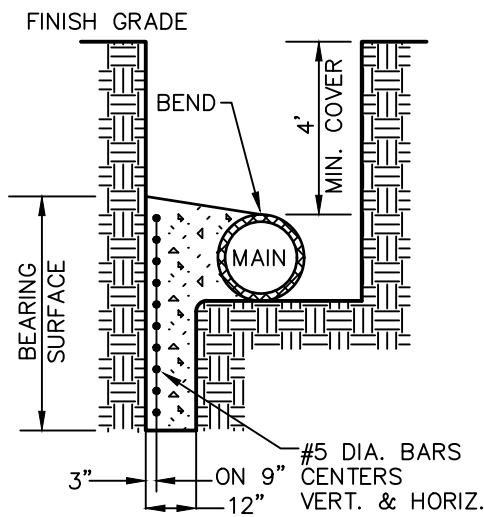
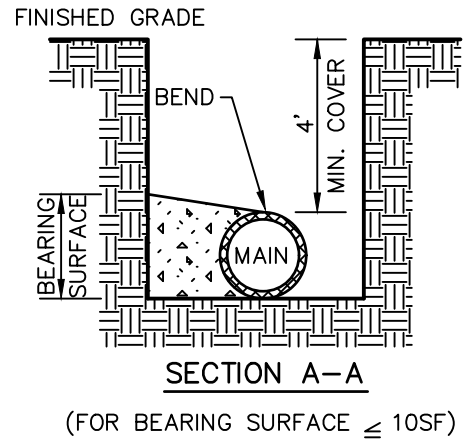
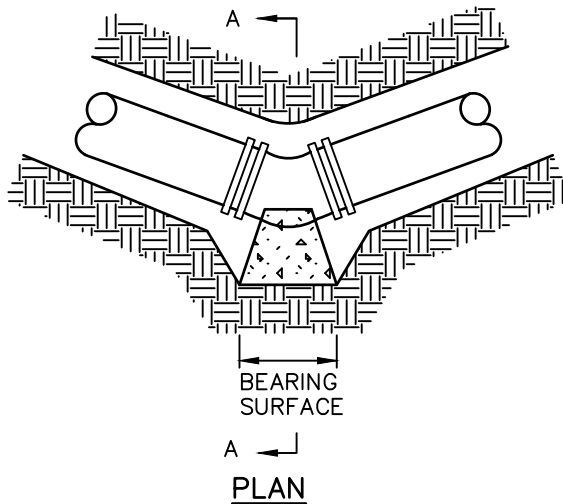

## HORIZONTAL THRUST BLOCK

NTS

**NOTES:**

1. ALL CONCRETE SHALL HAVE A MINIMUM COMPRESSION STRENGTH OF 3,000 P.S.I.
2. ALL REINFORCING STEEL SHALL BE DEFORMED BARS U-SHAPED AROUND PIPE.
3. ALL FITTINGS AND JOINTS SHALL BE ENVELOPED WITH 8 MIL. POLYETHYLENE FILM BEFORE PLACING CONCRETE.
4. PAINT ALL EXPOSED STEEL WITH TWO COATS OF ASTM D1187 ASPHALT EMULSION.
5. FOR THE REQUIRED BEARING SURFACE AREAS SEE STANDARD DETAIL M-6.

BUCKS COUNTY WATER & SEWER AUTHORITY			
DWG. BY: TSB	CKD. BY:	HORIZONTAL THRUST BLOCK	
DATE: 7-24-19	SCALE: None		
REVISION	DATE		
		STANDARD DETAIL	M-3

S:\mydocs\BCWSA Standard Detail Revisions\BCW-M\SPEC\SBCW-M.DWG Nov 25, 2019 2:37pm

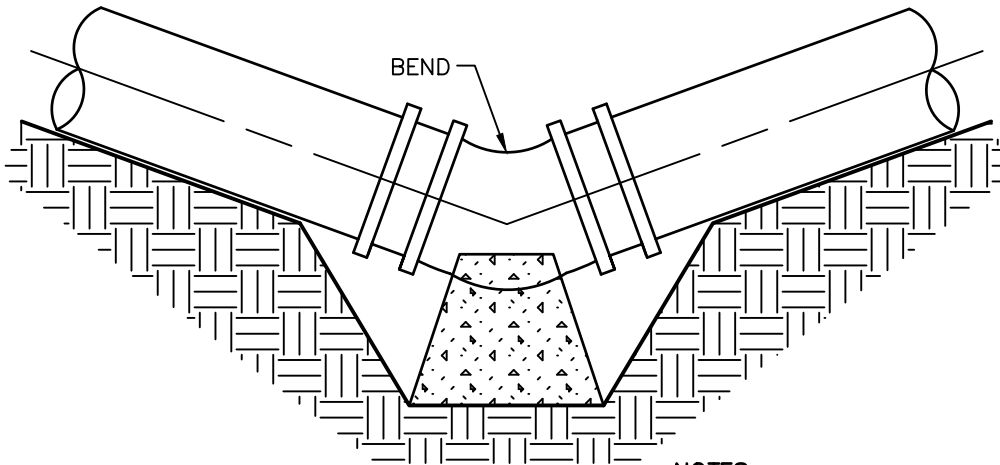

**NOTES:**

1. ALL CONCRETE SHALL HAVE A MIN. COMPRESSIVE STRENGTH OF 3,000 P.S.I.
2. ALL FITTINGS AND JOINTS SHALL BE COVERED WITH POLYETHYLENE FILM BEFORE PLACING CONCRETE.
3. PAINT ALL EXPOSED STEEL WITH TWO COATS OF ASTM D1187 ASPHALT EMULSION.
4. FOR REQUIRED BEARING SURFACE AREAS SEE STANDARD DETAIL M-6.

TYPICAL SECTION

VERTICAL DOWNWARD THRUST BLOCK

NTS

BUCKS COUNTY WATER & SEWER AUTHORITY			
DWG. BY: TSB	CKD. BY:	VERTICAL DOWNWARD THRUST BLOCK	
DATE: 7-24-19	SCALE: None		
REVISION	DATE	STANDARD DETAIL M-4	

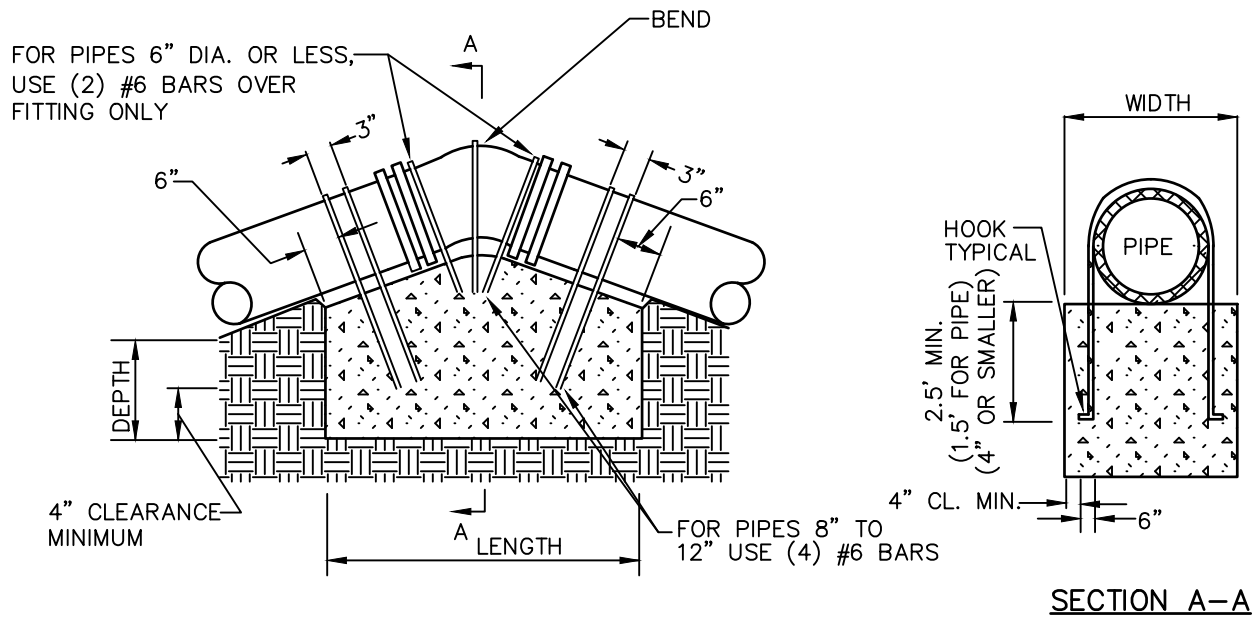

**NOTES:**

1. ALL CONCRETE SHALL HAVE A MINIMUM COMPRESSIVE STRENGTH OF 3,000 P.S.I.
2. ALL REINFORCING STEEL SHALL BE DEFORMED BARS U-SHAPED AROUND PIPE.
3. ALL FITTINGS AND JOINTS SHALL BE COVERED WITH POLYETHYLENE FILM BEFORE PLACING CONCRETE.
4. PAINT ALL EXPOSED STEEL WITH TWO COATS OF ASTM D1187 ASPHALT EMULSION.

CONCRETE BLOCKING DIMENSIONS, VERTICAL THRUST UPWARD FOR PRESSURES LESS THAN 100 PSI									
PIPE SIZES	LENGTH			WIDTH			DEPTH		
	11.25 °	22.25 °	45 °	11.25 °	22.25 °	45 °	11.25 °	22.25 °	45 °
4" AND LESS	2'	2'	3'	1.5'	1.5'	2'	2'	2'	2'
6" & 8"	3'	4'	6'	3'	3'	3'	2'	3'	4'
10" & 12"	3.5'	4'	7'	4'	4'	4'	2.5'	3'	4'

**NOTES:**

1. THIS CHART HAS BEEN DEVELOPED FOR D.I.P. WITH A 100 PSI WORKING PRESSURE. A 50% SURGE PRESSURE INCREASE AND 1.5 SAFETY FACTOR. CASE SPECIFIC CALCULATIONS ARE REQUIRED WHERE THE WORKING PRESSURE EXCEEDS 100 PSI AND/ OR SURGE PRESSURE EXCEEDS 50% OF WORKING PRESSURE.
2. FOR VERTICAL THRUST DOWNWARD, SEE STANDARD DETAIL M-4.
3. INSTALL MEGALUGS ON ALL FITTINGS.

**VERTICAL UPWARD THRUST BLOCK**

NTS

BUCKS COUNTY WATER & SEWER AUTHORITY			
DWG. BY: TSB	CKD. BY:	VERTICAL UPWARD THRUST BLOCK	
DATE: 7-24-19	SCALE: None		
REVISION	DATE		
		STANDARD DETAIL	M-5

## BEARING SURFACE REQUIRED – Sq. Ft. FOR WORKING PRESSURES UP TO 100 P.S.I. (SEE NOTE 1)

PIPE SIZE	3"					4"					6"					8"				
TYPE OF BEARING MATERIAL AND ALLOWABLE LOADS	DEGREE OF BEND OR DEFLECTION																			
	D.E.	90°	45°	22.5°	11.25°	D.E.	90°	45°	22.5°	11.25°	D.E.	90°	45°	22.5°	11.25°	D.E.	90°	45°	22.5°	11.25°
SOFT CLAY (1,000#/SF)	1.8	2.6	1.4	1.0	1.0	2.7	3.8	2.1	1.1	1.0	5.6	7.9	4.3	2.2	1.1	9.6	13.6	7.4	3.8	1.9
SILT (1,500#/SF)	1.2	1.7	1.0	1.0	1.0	1.8	2.6	1.4	1.0	1.0	3.7	5.3	2.9	2.2	1.0	6.4	9.1	4.9	2.5	1.3
SANDY SILT (3,000#/SF)	1.0	1.0	1.0	1.0	1.0	1.0	1.3	1.0	1.0	1.0	1.9	2.6	1.4	1.1	1.0	3.2	4.5	2.5	1.3	1.0
SAND (4,000#/SF)	1.0	1.0	1.0	1.0	1.0	1.0	1.0	1.0	1.0	1.0	1.4	2.0	1.1	1.0	1.0	2.4	3.4	1.8	1.0	1.0
SANDY CLAY (6,000#/SF)	1.0	1.0	1.0	1.0	1.0	1.0	1.0	1.0	1.0	1.0	1.0	1.3	1.0	1.0	1.0	1.6	2.3	1.2	1.0	1.0
HARD CLAY (9,000#/SF)	1.0	1.0	1.0	1.0	1.0	1.0	1.0	1.0	1.0	1.0	1.0	1.0	1.0	1.0	1.0	1.1	1.5	1.0	1.0	1.0

PIPE SIZE	10"					12"					14"					16"				
TYPE OF BEARING MATERIAL AND ALLOWABLE LOADS	DEGREE OF BEND OR DEFLECTION																			
	D.E.	90°	45°	22.5°	11.25°	D.E.	90°	45°	22.5°	11.25°	D.E.	90°	45°	22.5°	11.25°	D.E.	90°	45°	22.5°	11.25°
SOFT CLAY (1,000#/SF)	14.5	20.5	11.1	5.7	2.8	20.5	29.0	15.7	8.0	4.0	27.6	39.0	21.1	10.8	5.4	35.7	50.4	27.3	13.9	7.0
SILT (1,500#/SF)	9.7	13.7	7.4	3.8	1.9	13.7	19.3	10.5	5.3	2.7	18.4	26.0	14.1	7.2	3.6	23.8	33.6	18.2	9.3	4.7
SANDY SILT (3,000#/SF)	4.8	6.8	3.7	1.9	1.0	6.8	9.7	5.2	2.7	1.3	9.2	13.0	7.0	3.6	1.8	11.9	16.8	9.1	4.6	2.3
SAND (4,000#/SF)	3.6	5.1	2.8	1.4	1.0	5.1	7.3	3.9	2.0	1.0	6.9	9.7	5.3	2.7	1.4	8.9	12.6	6.8	3.5	1.7
SANDY CLAY (6,000#/SF)	2.4	3.4	1.9	1.0	1.0	3.4	4.8	2.6	1.3	1.0	4.6	6.5	3.5	1.8	1.0	5.9	8.4	4.5	2.3	1.2
HARD CLAY (9,000#/SF)	1.6	2.3	1.2	1.0	1.0	2.3	3.2	1.7	1.0	1.0	3.1	4.3	2.3	1.2	1.0	4.0	5.6	3.0	1.5	1.0

MIN. SQUARE FEET OF BEARING SURFACE REQUIRED FOR HORIZONTAL THRUST BLOCKING AND VERTICAL THRUST DOWNWARD.

**NOTES:**

1. THIS CHART HAS BEEN DEVELOPED FOR D.I.P. WITH A 100 PSI WORKING PRESSURE, A 50% SURGE PRESSURE INCREASE AND 1.5 SAFETY FACTOR. CASE SPECIFIC CALCULATIONS ARE REQUIRED WHERE THE WORKING PRESSURE EXCEEDS 100 PSI AND/ OR SURGE PRESSURE EXCEEDS 50% OF WORKING PRESSURE.
2. D.E. = DEAD END
3. MIN. THRUST BLOCK AREA IS 1.0 SQ. FEET.
4. MEGALUG RESTRAINT SHALL BE INSTALLED AT ALL FITTINGS.

### HORIZONTAL AND VERTICAL DOWNWARD THRUST BLOCK BEARING SURFACE AREAS

NTS

BUCKS COUNTY WATER & SEWER AUTHORITY			
DWG. BY: TSB	CKD. BY:	HORIZONTAL & VERTICAL DOWNWARD THRUST BLOCK BEARING SURFACE AREAS	
DATE: 7-24-19	SCALE: None		
REVISION	DATE		
STANDARD DETAIL		M-6	

TAPPED GROUT HOLE (TYP.)  
 PROVIDE 1 1/2" THREADED  
 FITTINGS SPACED EVERY 4' ON  
 CENTER. ALTERNATE FITTING  
 LOCATIONS BETWEEN 12, 4 AND  
 8 O'CLOCK POSITIONS AND 10,  
 2 AND 6 O'CLOCK POSITIONS.

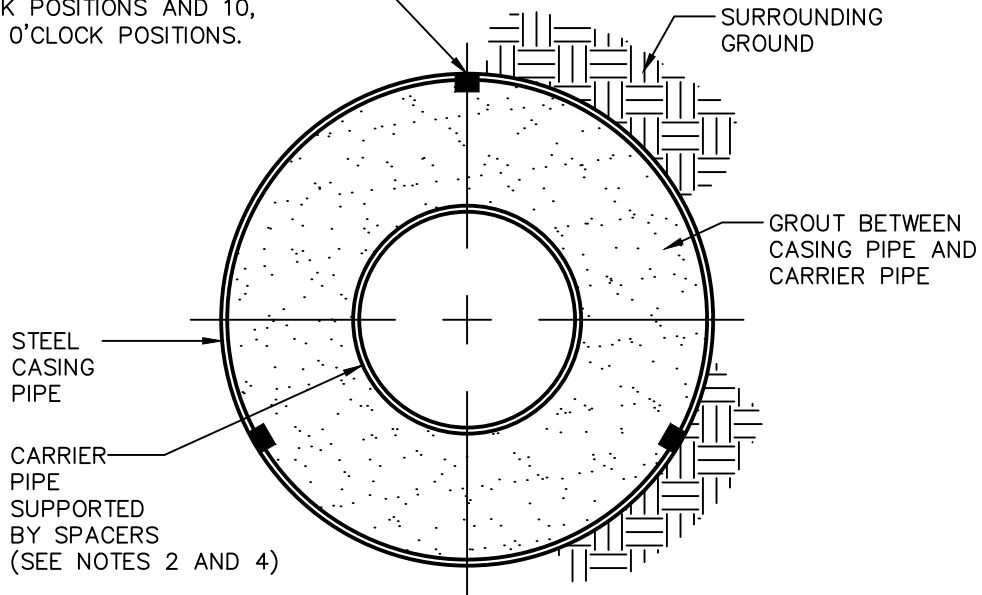

**NOTES:**

1. PENNDOT OR RAILROAD REQUIREMENTS CONTROL AS APPROPRIATE.
2. PROVIDE SPACERS AS REQUIRED TO MAINTAIN PROPER ALIGNMENT OF CARRIER PIPE.
3. ENDS OF CASING PIPE SHALL BE SEALED WITH BRICK MASONRY CONSTRUCTION AFTER ALL TESTS HAVE BEEN COMPLETED AND ACCEPTED BY ENGINEER.
4. REFER TO SECTION 02300 OF SPECIFICATIONS.

**JACKING CONDUIT**

NTS

S:\mydocs\BCWSA Standard Detail Revisions\BCW-M\SPEC\SBCW-M.DWG Nov 25, 2019 2:37pm

BUCKS COUNTY WATER & SEWER AUTHORITY			
DWG. BY: TSB	CKD. BY:	JACKING CONDUIT	
DATE: 7-24-19	SCALE: None		
REVISION	DATE		
		STANDARD DETAIL	M-7

S:\mydocs\BCWSA Standard Detail Revisions\BCW-M\SPEC\SBCW-M.DWG Nov 25, 2019 2:37pm

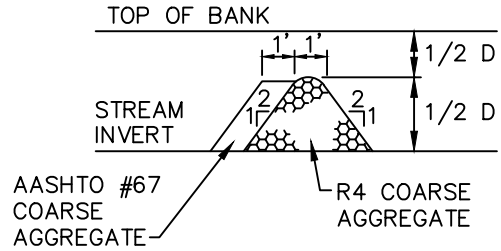
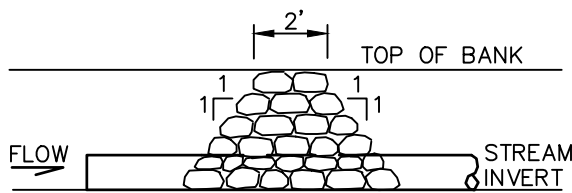
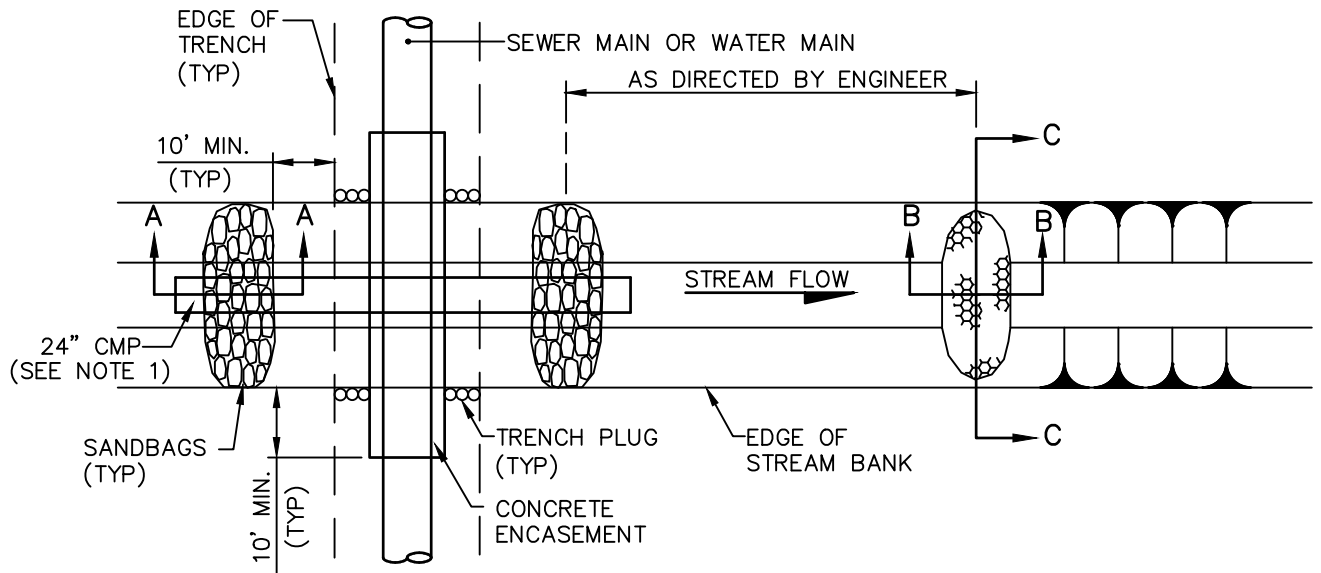

D = DEPTH OF WATER AT CHANNEL CAPACITY.

**SECTION A-A**

**SECTION B-B**

**NOTES:**

1. INSTALL ADDITIONAL OR LARGER PIPES AS NECESSARY TO CONVEY FLOW.
2. THIS DETAIL IS PROVIDED AS AN EXAMPLE FOR A SMALL STREAM CROSSING. THE CONTRACTOR IS DIRECTED TO FOLLOW THE APPROVED COUNTY CONSERVATION DISTRICT PLAN.
3. USE OF PUMPS MAY BE REQUIRED.

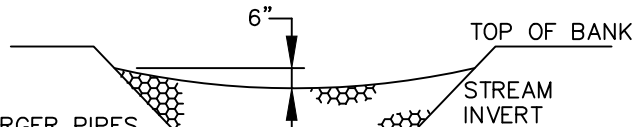

**SECTION C-C**

**SEDIMENTATION DIKE**

**PIPE STREAM CROSSING – ALTERNATIVE "A"**

NTS

BUCKS COUNTY WATER & SEWER AUTHORITY			
DWG. BY: TSB	CKD. BY:	PIPELINE STREAM CROSSING – ALTERNATIVE "A"	
DATE: 7-24-19	SCALE: None		
REVISION	DATE	STANDARD DETAIL M-8	

S:\mydocs\BCWSA Standard Detail Revisions\BCW-M\SPEC\SBCW-M.DWG Nov 25, 2019 2:37pm

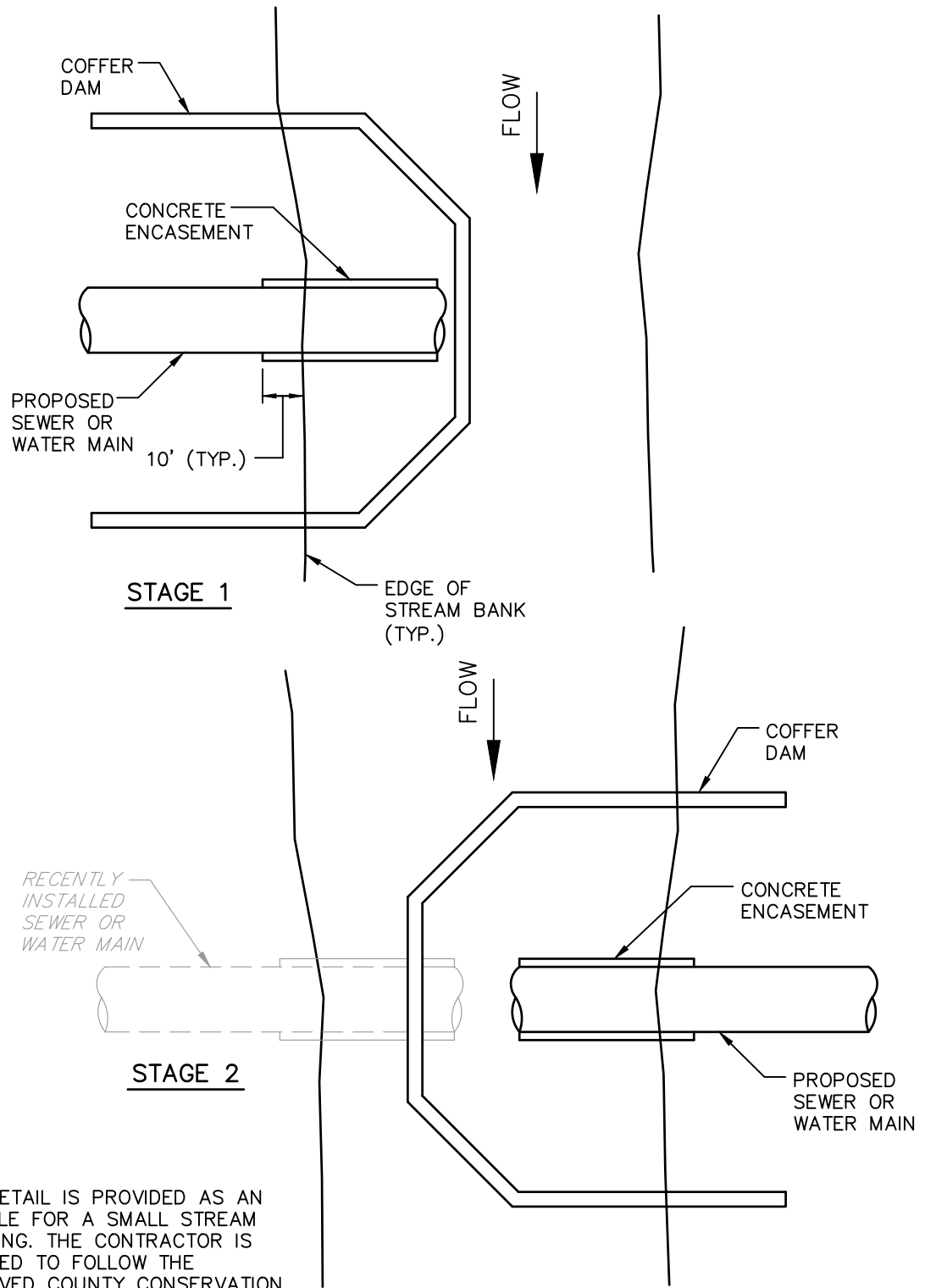

**NOTE:**

THIS DETAIL IS PROVIDED AS AN EXAMPLE FOR A SMALL STREAM CROSSING. THE CONTRACTOR IS DIRECTED TO FOLLOW THE APPROVED COUNTY CONSERVATION DISTRICT PLAN.

**PIPELINE STREAM CROSSING ALTERNATIVE "B"**

NTS

BUCKS COUNTY WATER & SEWER AUTHORITY			
DWG. BY: TSB	CKD. BY:	PIPELINE STREAM CROSSING ALTERNATIVE "B"	
DATE: 7-24-19	SCALE: None		
REVISION	DATE	STANDARD DETAIL M-9	

S:\mydocs\BCWSA Standard Detail Revisions\BCW-M\SPEC\SBCW-M.DWG Nov 25, 2019 2:37pm

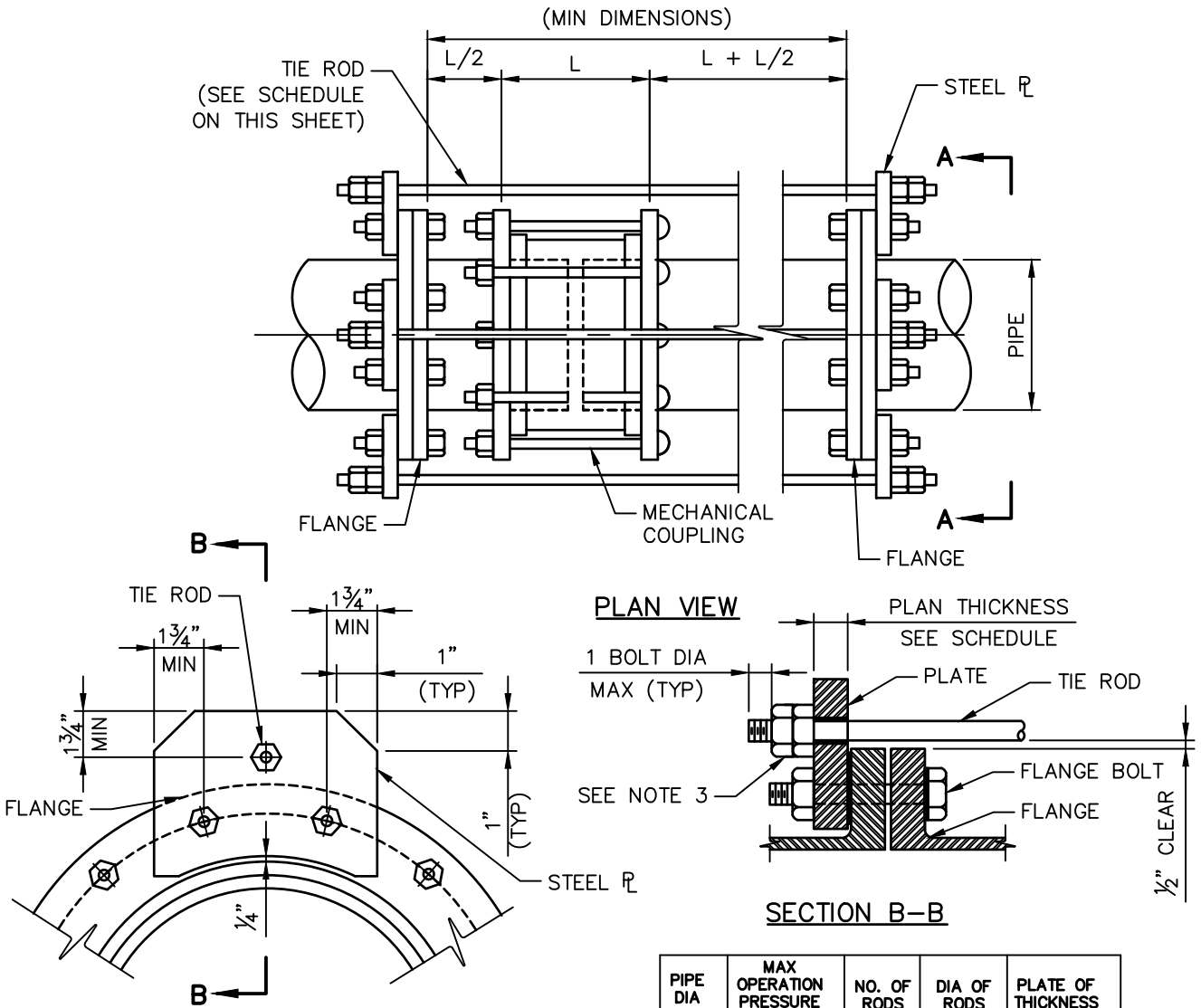

**NOTES:**

1. TIE RODS SHALL CONFORM TO ASTM A-588 SPECIFICATION.
2. STEEL PLATE SHALL CONFORM TO ASTM A-36 SPECIFICATION.
3. INSIDE NUT TO BE HAND TIGHT, AND TWO NUTS SHALL BE TIGHTENED AGAINST EACH OTHER.
4. STRAPPING DESIGN INCLUDES SURGE PRESSURE ADDED TO OPERATING PRESSURE IN PSI.
5. WHEN THE STRAPPING ASSEMBLY IS LOCATED NEAR THE FLANGED VALVE, PROVIDE A FLANGED SPOOL PIECE (1'-0" MIN LENGTH) BETWEEN THE VALVE AND ASSEMBLY IN ORDER TO AVOID STRAPPING DIRECTLY TO THE VALVE.

PIPE DIA	MAX OPERATION PRESSURE	NO. OF RODS	DIA OF RODS	PLATE OF THICKNESS
4"	125	2	3/4"	3/4"
	250	2	3/4"	3/4"
6"	125	2	3/4"	3/4"
	250	2	3/4"	3/4"
8"	125	2	7/8"	1"
	250	2	7/8"	1 1/8"
10"	125	2	7/8"	1 1/8"
	250	3	7/8"	1 1/8"
12"	125	3	7/8"	1 1/8"
	250	4	7/8"	1 1/8"
14"	125	4	7/8"	1 1/4"
	250	4	1"	1 1/4"
16"	125	4	1"	1 1/4"
	250	4	1 1/8"	1 1/2"
18"	125	4	1"	1 1/2"
	250	6	1"	1 1/2"
20"	125	4	1"	1 1/2"
	250	6	1 1/8"	1 1/2"
24"	125	6	1"	1 1/2"
	250	6	1 1/8"	1 3/4"
30"	125	7	1 1/8"	1 3/4"
	250	7	1 1/2"	2"

**STRAPPING RESTRAINT HARNESS DETAIL**

NTS

BUCKS COUNTY WATER & SEWER AUTHORITY			
DWG. BY: TSB	CKD. BY:	STRAPPING RESTRAINT HARNESS DETAIL	
DATE: 7-24-19	SCALE: None		
REVISION	DATE		
		STANDARD DETAIL	M-10

S:\mydocs\BCWSA Standard Detail Revisions\BCW-TR\SPEC\SBCW-TR.DWG Nov 25, 2019 2:42pm

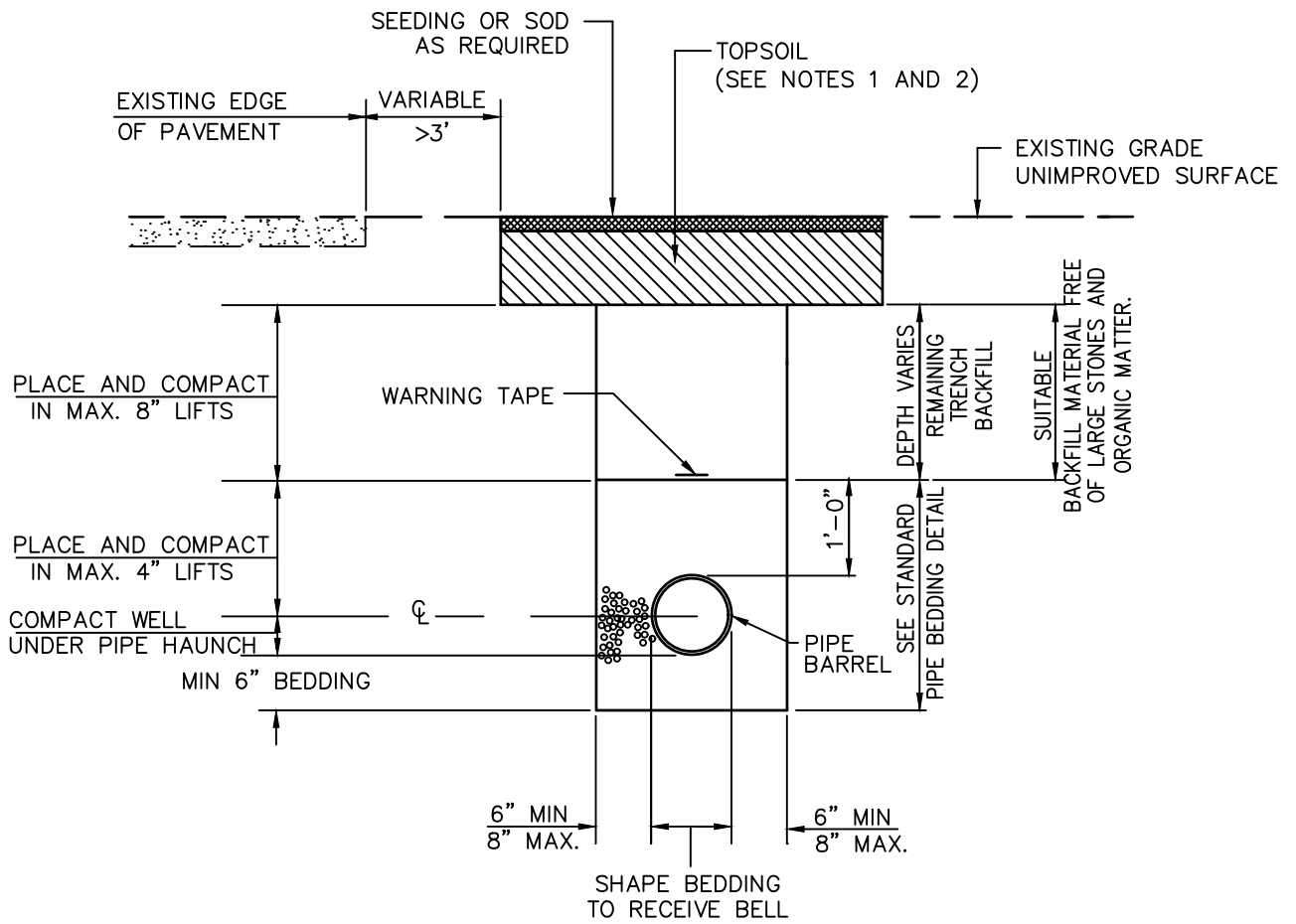

**NOTES:**

1. THE TOP 6" OF ALL TRENCHES IN NON-WETLAND AREAS SHALL BE BACKFILLED WITH TOPSOIL.
2. THE TOP 18" OF ALL TRENCHES IN WETLANDS SHALL BE BACKFILLED WITH PREVIOUSLY STRIPPED TOPSOIL.
3. ALL RESTORATION SHALL BE IN ACCORDANCE WITH PENNDOT PUBLICATION 408 AND PA CODE TITLE 67 CHAPTER 459.
4. SPECIAL CONDITION OF OCCUPANCY PERMIT MAY SUPERSEDE THIS DETAIL.

**TRENCH RESTORATION FOR UNIMPROVED SHOULDER OF STATE HIGHWAY, TOWNSHIP ROADS OR IN EASEMENT**

NTS

BUCKS COUNTY WATER & SEWER AUTHORITY			
DWG. BY: TSB	CKD. BY:	TRENCH RESTORATION FOR UNIMPROVED SHOULDER OF STATE HIGHWAY, TOWNSHIP ROAD, OR IN EASEMENT	
DATE: 7-24-19	SCALE: None		
REVISION	DATE		
		STANDARD DETAIL	TR-1

S:\mydocs\BCWSA Standard Detail Revisions\BCW-TR\SPEC\SBCW-TR.DWG Nov 25, 2019 2:42pm

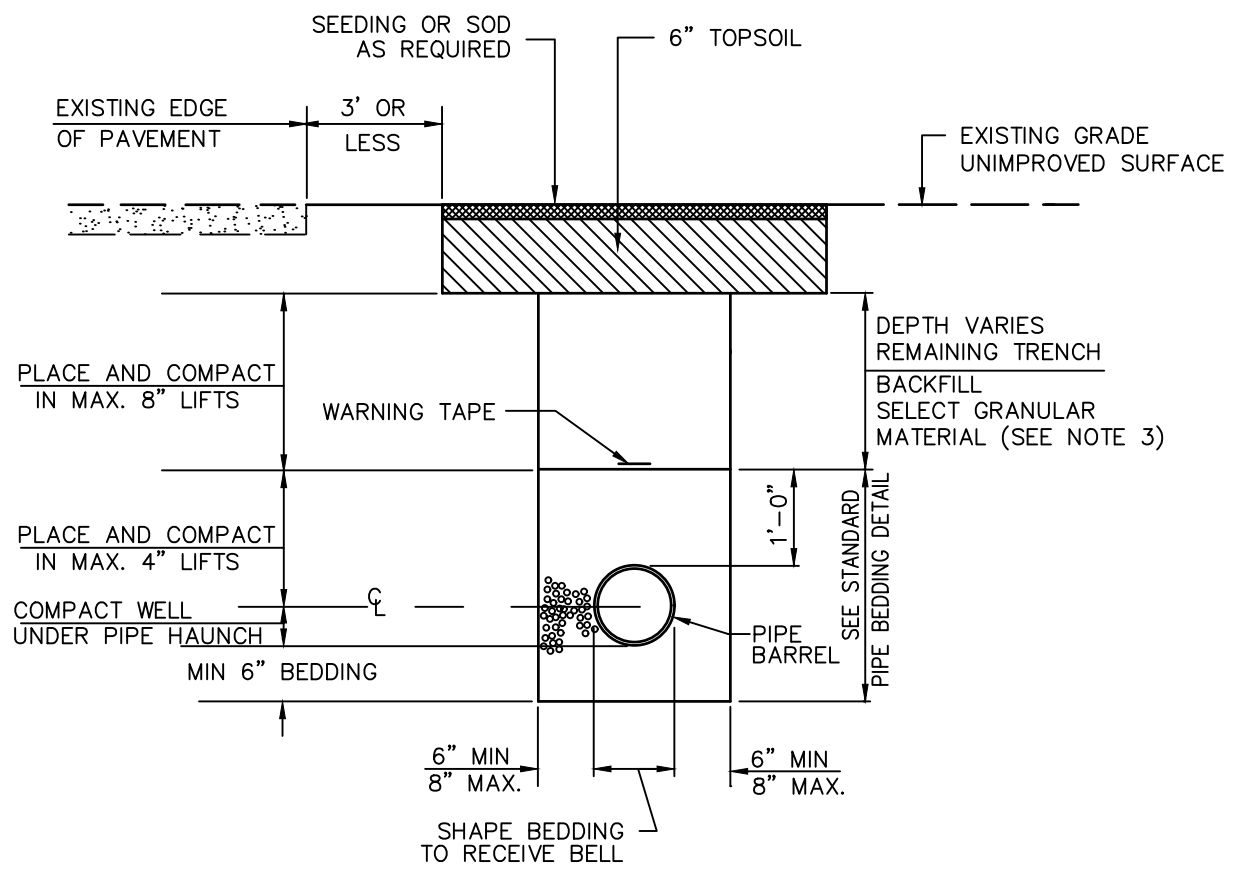

**NOTES:**

1. ALL RESTORATION TO BE IN ACCORDANCE WITH PENNDOT PUBLICATION 408 AND PA CODE TITLE 67 CHAPTER 459.
2. SPECIAL CONDITIONS OF OCCUPANCY PERMIT MAY SUPERSEDE THIS DETAIL.
3. BACKFILL SHALL BE 2RC (STATE ROADS) OR 2A COARSE AGGREGATE MATERIAL AS REQUIRED BY PERMIT.

**TRENCH RESTORATION FOR UNIMPROVED SHOULDER OF STATE HIGHWAY, OR TOWNSHIP ROAD (LESS THAN 3 FT FROM EDGE OF PAVEMENT)**

NTS

BUCKS COUNTY WATER & SEWER AUTHORITY			
DWG. BY: TSB	CKD. BY:	TRENCH RESTORATION FOR UNIMPROVED SHOULDER OF STATE HIGHWAY OR TOWNSHIP ROAD (< 3' FROM EDGE OF PAVEMENT)	
DATE: 7-24-19	SCALE: None		
REVISION	DATE		
		STANDARD DETAIL	TR-2

S:\mydocs\BCWSA Standard Detail Revisions\BCW-TR\SPEC\SBCW-TR.DWG Nov 25, 2019 2:42pm

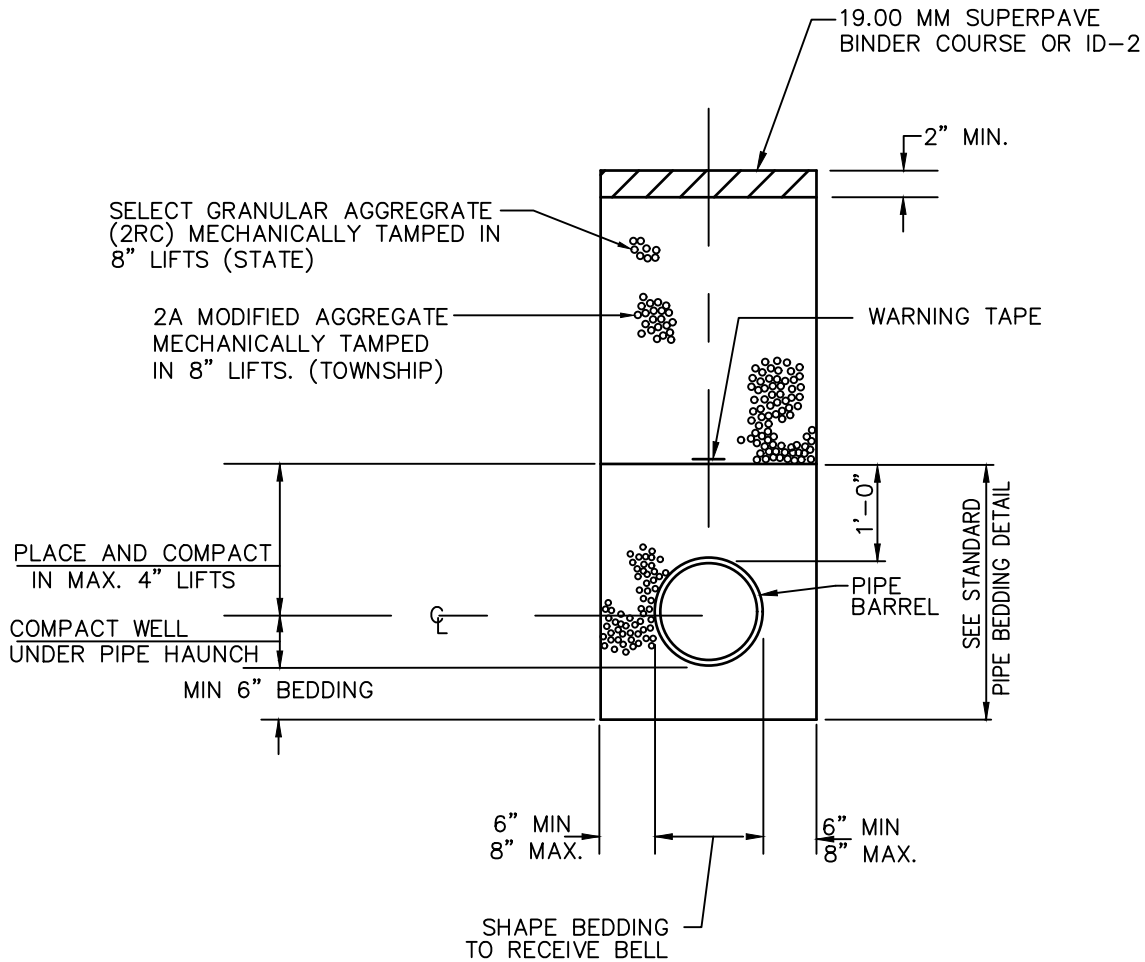

**NOTES:**

1. SPECIAL CONDITIONS OF THE TOWNSHIP ROAD OPENING PERMIT MAY SUPERSEDE THIS DETAIL.
2. CONTRACTOR TO MAINTAIN TEMPORARY PAVING UNTIL PERMANENT PAVING IS COMPLETED.

**TEMPORARY PAVEMENT  
FOR TOWNSHIP ROAD AND STATE HIGHWAY**

NTS

BUCKS COUNTY WATER & SEWER AUTHORITY			
DWG. BY: TSB	CKD. BY:	TEMPORARY PAVEMENT FOR TOWNSHIP ROAD AND STATE HIGHWAY	
DATE: 7-24-19	SCALE: None		
REVISION	DATE		
		STANDARD DETAIL	TR-3

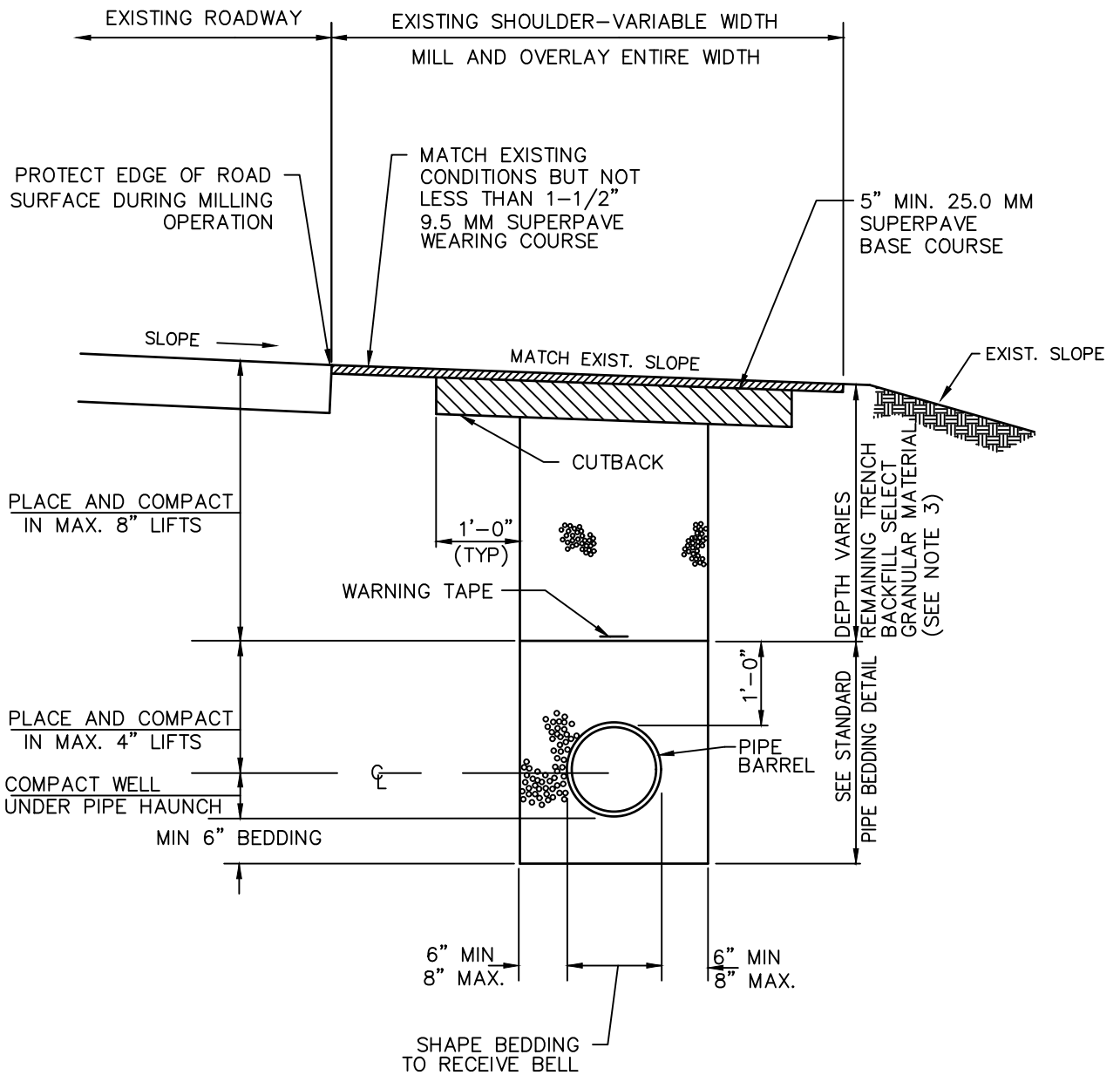

**NOTES:**

1. ALL RESTORATION TO BE IN ACCORDANCE WITH PENNDOT PUBLICATION 408 AND PA CODE TITLE 67 CHAPTER 459.
2. SPECIAL CONDITIONS OF OCCUPANCY PERMIT MAY SUPERSEDE THIS DETAIL.
3. BACKFILL SHALL BE 2RC (STATE ROAD) OR 2A MODIFIED (TOWNSHIP ROAD) AGGREGATE MATERIAL AS REQUIRED BY PERMIT.

**TRENCH RESTORATION FOR STABILIZED SHOULDER  
OF STATE HIGHWAY OR TOWNSHIP ROAD**

NTS

BUCKS COUNTY WATER & SEWER AUTHORITY			
DWG. BY: TSB	CKD. BY:	TRENCH RESTORATION FOR STABILIZED SHOULDER OF STATE HIGHWAY OR TOWNSHIP ROAD	
DATE: 7-24-19	SCALE: None		
REVISION	DATE		
		STANDARD DETAIL	TR-4

S:\mydocs\BCWSA Standard Detail Revisions\BCW-TR\SPEC\SBCW-TR.DWG Nov 25, 2019 2:42pm

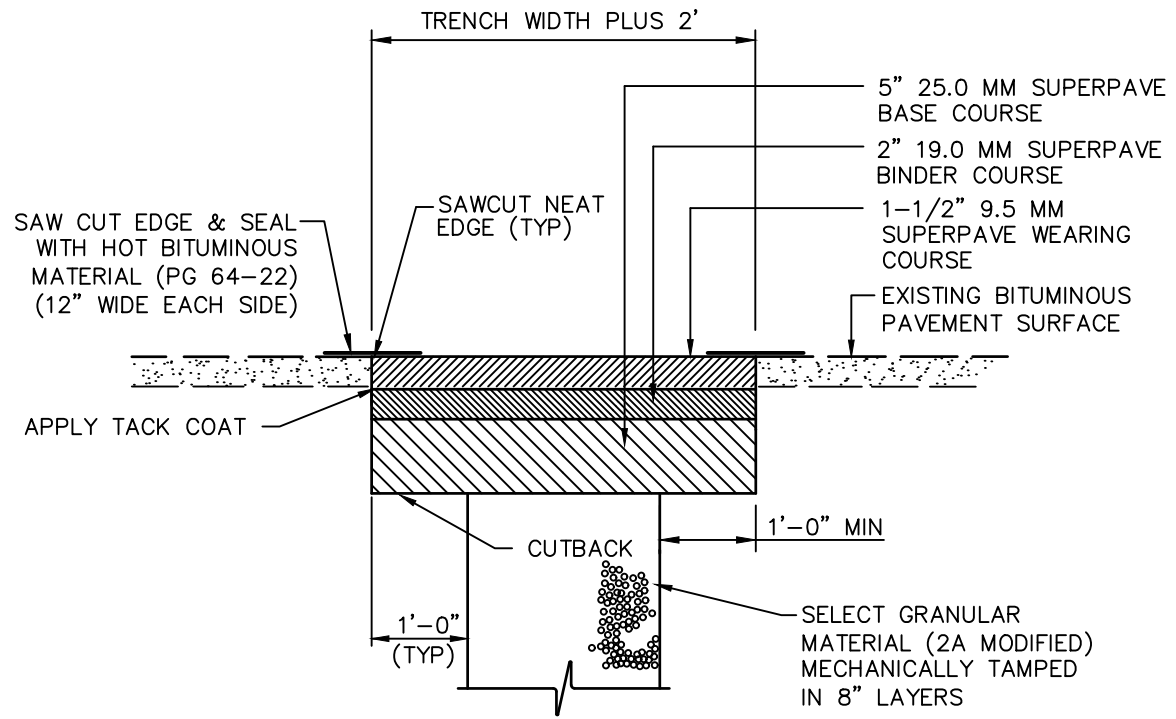

- NOTES:**
1. SPECIAL CONDITIONS OF THE TOWNSHIP ROAD OPENING PERMIT MAY SUPERSEDE THIS DETAIL.
  2. CONTRACTOR TO MAINTAIN TEMPORARY PAVING UNTIL PERMANENT PAVING IS COMPLETED.

**PERMANENT PAVEMENT, TRENCH RESTORATION AND BACKFILL FOR TOWNSHIP ROADS**

NTS

BUCKS COUNTY WATER & SEWER AUTHORITY			
DWG. BY: TSB	CKD. BY:	PERMANENT PAVEMENT, TRENCH RESTORATION AND BACKFILL FOR TOWNSHIP ROADS	
DATE: 7-24-19	SCALE: None		
REVISION	DATE		
		STANDARD DETAIL	TR-5

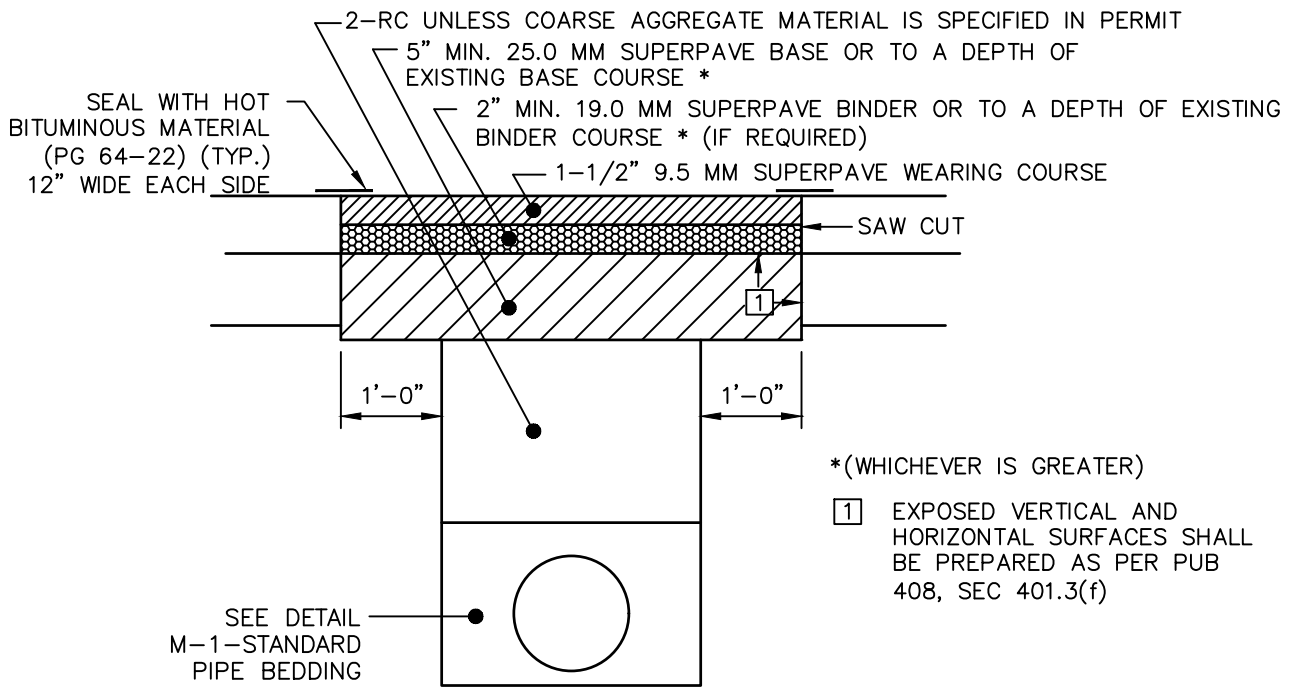

**FLEXIBLE PAVEMENT RESTORATION**

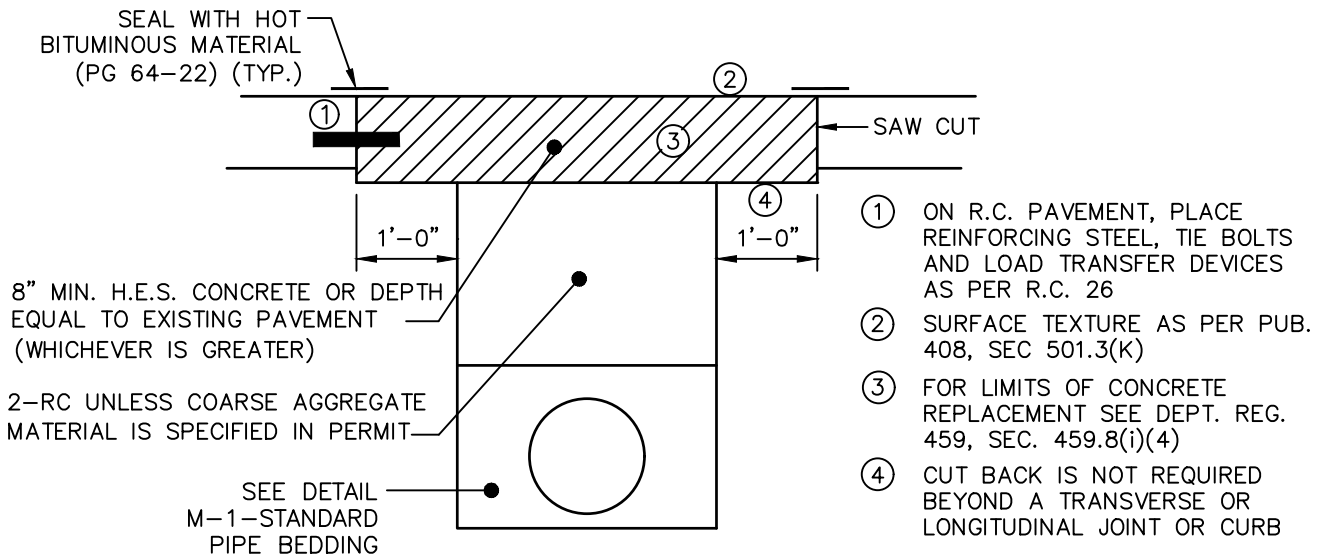

**NOTES:**

1. ALL RESTORATION TO BE IN ACCORDANCE WITH PA DOT PUBLICATION 408 AND PA CODE TITLE 67 CHAPTER 459.
2. SPECIAL CONDITIONS OF OCCUPANCY PERMIT MAY SUPERSEDE THIS DETAIL.

**RIGID PAVEMENT RESTORATION**

**PERMANENT PAVEMENT, TRENCH RESTORATION AND BACKFILL FOR STATE HIGHWAYS**

NTS

BUCKS COUNTY WATER & SEWER AUTHORITY			
DWG. BY: TSB	CKD. BY:	PERMANENT PAVEMENT, TRENCH RESTORATION AND BACKFILL FOR STATE HIGHWAYS	
DATE: 7-24-19	SCALE: None		
REVISION	DATE		
		STANDARD DETAIL	TR-6

S:\mydocs\BCWSA Standard Detail Revisions\BCW-TR\SPEC\SBCW-TR.DWG Nov 25, 2019 2:43pm

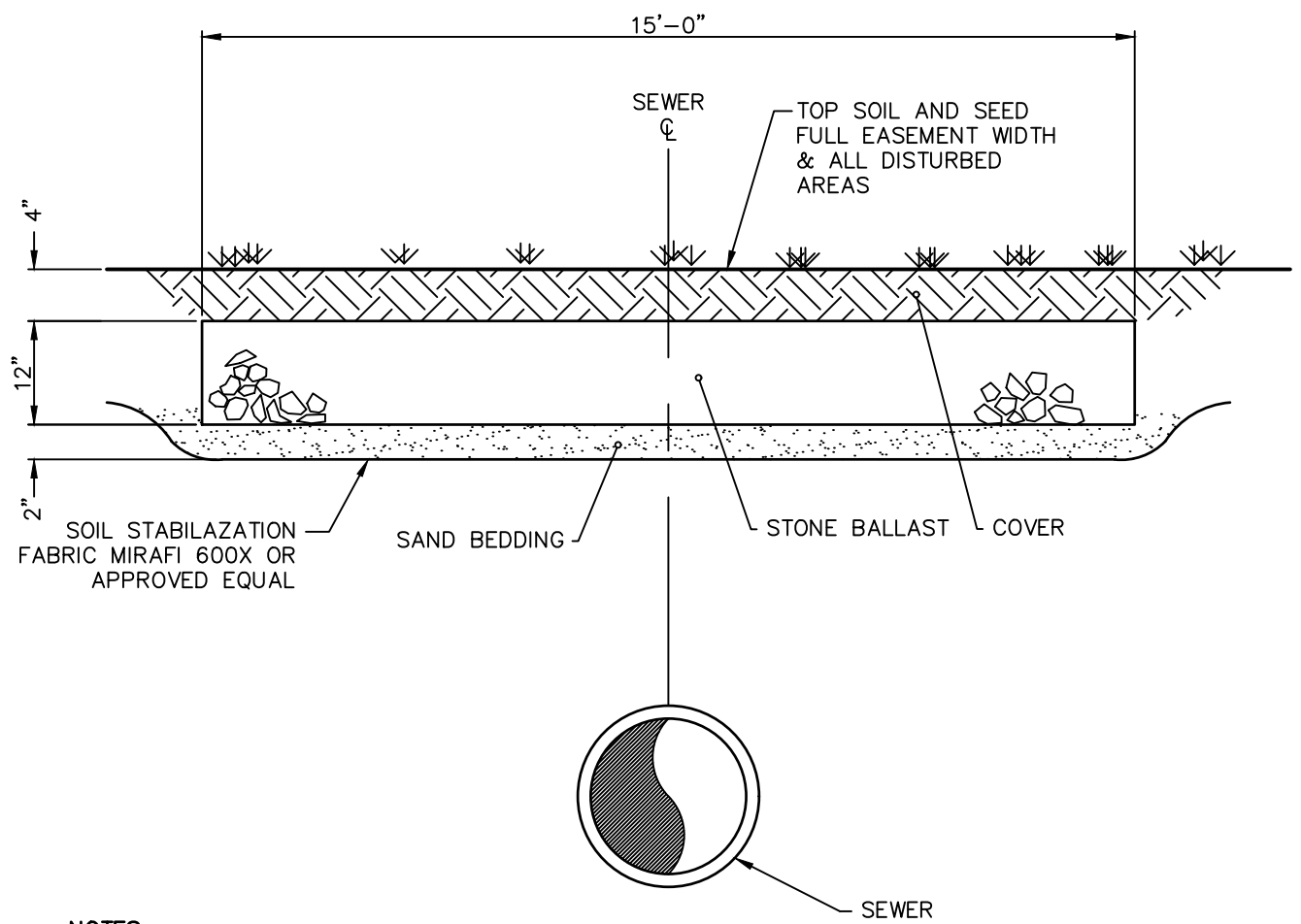

**NOTES:**

1. STABILIZATION FABRIC IS TO BE OMITTED IF SUBGRADE IS BEDROCK OR DENSE GRANULAR MATERIAL.
2. SURVEYORS MARKERS TO BE PLACED ON 100' C.C. BOTH SIDES OF 15' BASE. MARKER TO BE FLUSH WITH FINISH GRADE.
3. WHERE REQUIRED BY OWNER, STABILIZED ACCESS BEDS SHALL BE INSTALLED ALONG SEWER AND WATER MAINS LOCATED OUTSIDE ROADWAY RIGHTS-OF-WAY (IN EASEMENTS) FOR PURPOSE OF PROVIDING ACCESS TO MANHOLE AND PIPING LOCATIONS. STABILIZED ACCESS BED SHALL NOT BE INSTALLED IN WETLAND AREAS OR WATERWAYS.

**STABILIZED ACCESS BED DETAIL**

NTS

BUCKS COUNTY WATER & SEWER AUTHORITY			
DWG. BY: TSB	CKD. BY:	STABILIZED ACCESS BED DETAIL	
DATE: 7-24-19	SCALE: None		
REVISION	DATE	STANDARD DETAIL TR-7	